



HERCULES

**IMPORTANT
READ CAREFULLY BEFORE USE
KEEP SAFE FOR LATER REFERENCE**

TRANSLATION OF THE ORIGINAL OPERATING INSTRUCTIONS

EN

ELECTRIC BICYCLES

**NOS FS PRO, NOS FS COMP, NOS FS SPORT,
NOS SPORT**

18-R-0001 | 18-R-0002 | 18-R-0003 | 18-R-0005

034-11521 • 1.0 • 23.10.2017

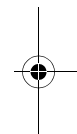
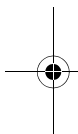

Copyright

© HERCULES GMBH

Distribution or reproduction of these operating instructions and utilisation or communication of their content is prohibited unless expressly approved. Any infringement will render the offender liable for compensation. All rights reserved in the event that a patent, utility model or industrial design is registered.

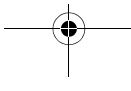

Data sheet

Surname, first name of the purchaser: _____

Date of purchase: _____

Model: _____

Frame number: _____

Type number: _____

Unladen weight (kg): _____

Tyre size: _____

Recommended tyre pressure (bar)*: front: _____ rear: _____

Wheel circumference (mm): _____

Company stamp and signature: _____

*After a tyre change, refer to the tyre markings for the permitted tyre pressures and make sure that they are observed. The recommended tyre pressure must not be exceeded.

Technical data

1 Technical data

Bicycle

Transportation temperature	5 °C - 25 °C
Ideal transportation temperature	10 °C - 15 °C
Storage temperature	5 °C - 25 °C
Ideal storage temperature	10 °C - 15 °C
Operation temperature	5 °C - 35 °C
Working environment temperature	15 °C - 25 °C
Charging temperature	10 °C - 30 °C
Power output/system	250 W (0.25 kW)
Shut-off speed	25 km/h

Table 1:

Bicycle technical data

Battery

Transportation temperature	5 °C - 25 °C
Ideal transportation temperature	10 °C - 15 °C
Storage temperature	5 °C - 25 °C
Ideal storage temperature	10 °C - 15 °C
Charging ambient temperature	10 °C - 30 °C

Table 2:

Battery technical data

Technical data

Command console with display

Operating temperature 5 °C to 35 °C

Storage temperature 5 °C - 25 °C

Table 3:

Technical data for battery of the command console with display

Emissions

A-weighted emission sound pressure level < 70 dB(A)

Total vibration level for the hands and arms < 2.5 m/s²

Highest effective value of weighted acceleration for the entire body < 0.5 m/s²

Operating frequency 2402-2408 MHz

max. transmit power (EIRP) 0.43 mW (-3.7 dBm)

Table 4:

Emissions from the bicycle*

*The safety requirements as per Radio Equipment Directive 2014/53/EU have been met. The bicycle and the charger can be used in residential areas without restriction.

USB port

Charge voltage 5 V

Charging current max. 500 mA

Table 5:

USB port technical data

Tightening torque

Axle nut tightening torque 35 Nm - 40 Nm

Handlebars clamping screw maximum tightening torque* 5 Nm - 7 Nm

Table 6:

Tightening torque values*

*if there is no other data on the component

Table of contents

1	Technical data	2
2	About these instructions	8
2.1	Manufacturer	8
2.2	Laws, standards and directives	9
2.3	Other valid documents	9
2.4	Subject to change	10
2.5	Language	10
2.6	Identifying	11
2.6.1	Operating instructions	11
2.6.2	Bicycle	11
2.7	For your safety	12
2.7.1	Instruction, training and customer service	12
2.7.2	Basic safety notes	13
2.7.3	Warnings	13
2.7.4	Safety markings	14
2.8	For your information	14
2.8.1	Instructions for actions	14
2.8.2	Information on the type plate	14
2.8.3	Language conventions	17
2.9	Type plate	18
3	Safety	19
3.1	Requirements for the rider	19
3.2	Personal protective equipment	19
3.3	Proper use	19
3.3.1	Mountain bike	20
3.4	Improper use	20
3.5	Personal protective equipment	20
3.6	Duty of care	21
3.6.1	Rider	21
3.6.2	User	22
4	Description	23
4.1	Overview	23
4.2	Handlebars	24
4.3	Wheel and fork	25
4.3.1	Valve	25
4.3.2	Suspension	26
4.4	Brake system	28
4.5	Electric drive system	29
4.5.1	Battery	31

Table of contents

4.5.1.1	Operating and charge status indicator	33
4.5.2	Running light	33
4.5.3	Display	33
4.5.3.1	USB port	35
4.5.3.2	Displays	35
5	Transportation, storage and assembly	38
5.1	Transportation	38
5.2	Storing	40
5.2.1	Break in operation	40
5.2.1.1	Preparing a break in operation	41
5.2.1.2	Carrying out break in operation	41
5.3	Assembly	42
5.3.1	Unpacking	42
5.3.2	Scope of delivery	43
5.3.3	Commissioning	43
5.3.3.1	Checking the battery	45
5.3.4	Installing the wheels with quick release	45
6	Adjusting the bicycle to the rider	47
6.1	Adjusting the saddle	47
6.1.1	Determining the seat height	47
6.1.2	Clamping the seat post with the quick release	48
6.1.3	Adjusting the sitting position and saddle tilt	49
6.2	Setting the handlebars	49
6.3	Setting the stem with quick release	50
6.4	Checking the clamping force of the quick releases	51
6.5	Basic setting for suspension and damping	51
6.5.1	Adjusting the hardness of the spring elements	52
6.5.1.1	Adjusting the hardness of the steel suspension fork	52
6.5.1.2	Adjusting the hardness of the air suspension elements	53
6.5.1.3	Front wheel	53
6.5.2	Setting the rebound damper	55
6.5.3	Setting the compression damper	57
6.6	Setting the grip distance of the brake lever	58
7	Operation	59
7.1	Before each ride	61
7.2	Using the kickstand	63
7.3	Battery	64
7.3.1	Removing the integrated battery	66
7.3.2	Inserting the integrated battery	66

Table of contents

7.3.3	Charging the battery	67
7.3.4	Waking the battery	69
7.4	Electric drive system	70
7.4.1	Switching on the drive system	70
7.4.2	Switching off the drive system	71
7.5	Command console with display	72
7.5.1	Using the pushing aid	72
7.5.2	Using the running light	73
7.5.3	Using the main beam	73
7.5.4	Selecting the level of assistance	73
7.5.5	Journey information	74
7.5.5.1	Switching the displayed journey information	74
7.5.5.2	Resetting all values in TOUR menu	74
7.5.6	Using the USB port	74
7.5.7	Using Bluetooth connection	75
7.5.7.1	Activating Bluetooth connectivity	75
7.5.7.2	Deactivating Bluetooth connectivity	75
7.6	Gear shift	76
7.7	Brakes	77
7.7.1	Using the brake	78
7.8	Suspension and damping	79
7.8.1	Locking the front wheel suspension	79
7.8.1.1	Fork lock on the suspension head	79
7.8.1.2	Fork lock on handlebars, version I	80
7.8.1.3	Fork lock on handlebars, version II	80
7.8.1.4	Fork lock on handlebars, version III	81
7.8.1.5	Fork lock on handlebars, version IV	81
7.8.1.6	Fork lock on handlebars, version V	82
7.8.2	Locking the compression damper	82
8	Maintenance	83
8.1	Cleaning and servicing	84
8.1.1	Battery	84
8.1.2	Display	84
8.1.3	Basic cleaning and preservation	85
8.1.4	Chain	85
8.2	Maintenance	86
8.2.1	Wheel	86
8.2.2	Brake system	87
8.2.3	Electrical cables and brake cables	87
8.2.4	Gear shift	87

Table of contents

8.2.5	USB port	87
8.2.6	Chain or belt tension	87
8.3	Service	89
8.4	Correcting and repairing	90
8.4.1	Using original parts only	90
8.4.1	Wheel quick release	91
8.4.1.1	Clamping the clamping lever	92
8.4.1.2	Clamping version I	92
8.4.1.3	Clamping version II	93
8.4.1.4	Clamping version III	94
8.4.1.5	Clamping version IV	95
8.4.1.6	Clamping version V	96
8.4.2	Adjusting the tyre pressure	99
8.4.2.1	Dunlop valve	99
8.4.2.2	Presta valve	100
8.4.2.3	Schrader valve	101
8.4.3	Adjusting the gear shift	102
8.4.3.1	Cable-operated gear shift, single-cable	102
8.4.3.2	Cable-operated gear shift, dual-cable	103
8.4.3.3	Cable-operated twist grip, dual-cable	104
8.4.4	Replacing the lighting	105
8.4.5	Setting the lamp	105
8.4.6	Repair by the specialist dealer	105
8.4.7	First aid for system messages	106
8.4.7.1	First aid	106
8.4.7.2	Specific error eradication	107
8.4.8	The electric drive system or display do not start up	108
8.5	Accessories	109
8.5.1	Child seat	110
8.5.2	Bicycle trailer	112
9	Recycling and disposal	113
10	EC declaration of conformity	115
11	List of tables	116
12	Table of figures	117
13	Index	119

About these instructions

2 About these instructions

Read these operating instructions before commissioning the bicycle in order to use all the functions correctly and safely. They are not a substitute for personal training by the supplying HERCULES specialist dealer. The operating instructions are a component part of the bicycle. Therefore, if it is re-sold at a later time, they must be handed over to the subsequent owner.

These operating instructions are mainly directed at the rider and user of the cycle. In general, they are technical laypersons.



Text passages which are directed expressly at specialist staff (e.g. bicycle mechanics), are clearly marked with a blue tool symbol.

Staff at all HERCULES specialist dealers have specialist training and qualifications, and are therefore capable of identifying risks and preventing hazards which may arise during maintenance, servicing and repairs on the bicycle. Information for specialist staff does not require technical laypersons to take any action.

2.1 Manufacturer

The manufacturer of the bicycle is:

HERCULES GMBH
Longericher Straße 2
50739 Köln, Germany

Tel.: +49 4471 18735 0
Fax: +49 4471 18735 29
E-mail: info@hercules-bikes.de
Internet: www.hercules-bikes.de

2.2 Laws, standards and directives

These operating instructions comply with the essential requirements from:

- the Machinery Directive 2006/42/EC,
- EN ISO 12100:2010 Safety of machinery – General principles of design – Risk assessment and reduction,
- EN ISO 4210-2:2015, Cycles – Safety requirements for bicycles – Part 2: Requirements for city and trekking, young adult, mountain and racing bicycles,
- EN 15194:2009+A1:2011 Cycles – Electrically power assisted cycles – EPAC bicycles,
- EN 11243:2016, Cycles – Luggage carriers for bicycles – Requirements and test methods,
- Radio Equipment Directive 2014/53/EC,
- EN 82079-1:2012, Preparation of instructions for use – Structuring, content and presentation – Part 1: General principles and detailed requirements,
- EN ISO 17100:2016-05, Translation Services – Requirements for translation service.

2.3 Other valid documents

These operating instructions are only complete in conjunction with the other valid documents.

The following document applies for this product:

- Charger operating instructions.

No other information is also applicable.

The constantly updated lists of approved accessories and parts are available to HERCULES specialist dealers.



About these instructions



2.4 Subject to change

The information contained in these operating instructions are the approved technical specifications at the time of printing. Any significant changes are included in a new issue of the operating instructions.

2.5 Language

The original operating instructions are written in German. A translation is not valid without the original operating instructions.

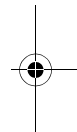
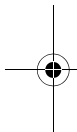

2.6 Identifying

2.6.1 Operating instructions

These operating instructions are printed in colour and glued (PUR glue) in an outer cover made of thin paper. HERCULES GMBH assumes no liability for copies of any kind, for example, black and white copies, loose pages or electronic copies.

The identification number of these operating instructions is made up of the document number, the version number and the release date. It can be found on the cover page and in the footer.

Identification number	034-11521_1.0_30.10.2017
-----------------------	--------------------------

Table 7:

Identification number of the operating instructions

2.6.2

Bicycle

These HERCULES operating instructions refer to the *model year* 2018. The production period is from July 2017 to June 2018. They are issued in August 2017.

The operating instructions are a component part of the following bicycles:

Type no.	Model	Bicycle type
18-R-0001	NOS FS PRO	City and trekking bicycle
18-R-0002	NOS FS COMP	City and trekking bicycle
18-R-0003	NOS FS SPORT	Mountain bike
18-R-0005	NOS SPORT	Mountain bike

Table 8:

Type number, model and bicycle type categorisation

About these instructions

2.7

For your safety

The safety concept of the bicycle comprises four elements:

- the instruction of the rider and/or user, and maintenance and repair of the bicycle by the HERCULES specialist dealer,
- the chapter on general safety,
- the warnings in these instructions and
- the safety marking on the type plates.

2.7.1

Instruction, training and customer service

The HERCULES specialist dealer and supplier provides customer service. Contact details can be found on the back page of these operating instructions and in the data sheet. If you are unable to contact your specialist dealer, you will find further HERCULES specialist dealers on www.hercules-bikes.de. They will also be able to attend to your customer service needs.



The HERCULES specialist dealer commissioned to perform repairs and maintenance work receives regular training.

The rider or the user of the bicycle will be instructed in person on the functions of the bicycle, in particular its electrical functions and correct use of the charger, at the latest when the bicycle is handed over by the supplying HERCULES specialist dealer.

Each rider to whom this bicycle is made available, must receive instruction on the functions of the bicycle. The operating instructions must be submitted to each rider in printed form and must be acknowledged and adhered to.

2.7.2 Basic safety notes

These operating instructions have a chapter with general safety notes [[▷ Chapter 3, page 19](#)]. The chapter stands out because of its grey background.

2.7.3 Warnings

Hazardous situations and actions are marked with warnings. The warnings in these operating instructions are shown as follows:





SIGNAL WORD	Type and source of the danger
	Description of the danger and the consequences.
	► Measures
	The following pictograms and signal words are used in the operating instructions for warnings and information notices:
	Will lead to serious or even fatal injuries if ignored. High-risk hazard.
	May lead to serious or even fatal injuries if ignored. Medium-risk hazard.
	May lead to minor or moderate injuries. Low-risk hazard.
	May lead to material damage if ignored.

Table 9: Meanings of the signal words

About these instructions

2.7.4

Safety markings

The following safety markings are used on the type plates of the bicycle:



General warning



Adhere to the instructions for use

Table 10:

Safety markings on the product

2.8

For your information

2.8.1

Instructions for actions

Instructions for actions are structured in accordance with the following pattern:

- ✓ Requirements (optional)
- ▶ Instruction for action
- ⇒ Result of the action (optional)

2.8.2

Information on the type plate

Alongside the warnings, the type plates of the products also contain other important information on the bicycle:

About these instructions





 1	only suitable for the road, no off-road riding or jumps
 2	suitable for roads, off-road riding and jumps of up to 15 cm
 3	suitable for rough off-road riding and jumps of up to 61 cm
 4	suitable for rough off-road riding and jumps of up to 122 cm
 5	suitable for the most difficult terrain

Table 11:

Area of use







	City and trekking bicycle
	Child's bicycle / bicycle for young adults
	BMX bicycle
	Mountain bike
	Racing bicycle
	Carrier bicycle
	Folding bicycle

Table 12:

Bicycle type

About these instructions



Read the instructions



Separate collection of electrical and electronic devices



Separate collection of batteries



Must not be thrown into fire (burning prohibited)



Must not be thrown into water (immersed)



Device of protection class II



Only suitable for use indoors



Fuse (device fuse)



EU conformity



Recyclable material

Table 13:

Information on the type plate

2.8.3 Language conventions

The bicycle described in these operating instructions may be equipped with alternative components. The equipment of the bicycle is defined by the respective type number. If applicable, the notes *alternative equipment* and *alternative version* make reference to the use of alternative components.

Alternative equipment describes additional components which are not necessarily an integral part of every bicycle in these instructions.

Alternative version explains the various variants of components if they differ in use.

The following terms are used for better legibility:

Term	Meaning
Operating instructions	Original operating instructions or translation of the original operating instructions
Bicycle	Electric motor driven cycle
Motor	Drive motor

Table 14:

Simplified terms

The following conventions are used in these operating instructions:

Convention	Use
<i>Italics</i>	Entry in the index
SPACED	Displays on the <i>display screen</i>
[▷ <i>Example, page numbering</i>]	Cross references
•	Bulleted lists

Table 15:

Conventions

About these instructions

2.9 Type plate

The type plate is situated on the *frame*. The type plate features the following information:

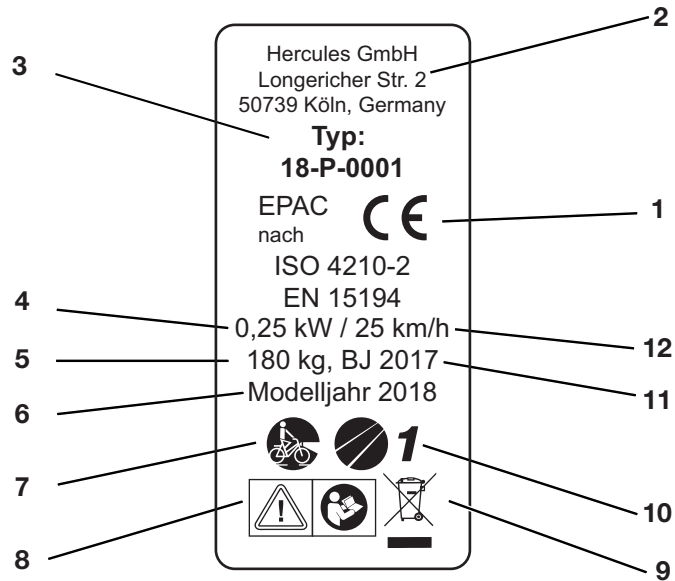

Figure 1:

Type plate, example

- 1 CE marking
- 2 Manufacturer
- 3 Type number
- 4 Maximum power output
- 5 Permitted total weight
- 6 Model year
- 7 *Bicycle type*
- 8 *Safety notes*
- 9 *Disposal information*
- 10 *Area of use*
- 11 Year of manufacture
- 12 Shut-off speed

3

Safety

3.1

Requirements for the rider

The physical and mental abilities of the rider must be sufficient for riding on public roads. The legal guardians hold sole responsibility for determining whether minors are suitable to use the bicycle.

3.2

Personal protective equipment

We recommend that you wear a suitable safety helmet. We also recommend that you wear typical, close-fitting cycling clothing and sturdy footwear.

3.3

Proper use

The bicycle must only be used in perfect, fully functional condition. National requirements may apply to the bicycle which differ from the standard equipment. For riding on public roads, some special regulations apply in relation to *running light*, *reflectors* and other components.

The general laws and the regulations for the prevention of accidents and environmental protection in the respective country of use must be adhered to. Proper use also includes all instructions for actions and check lists in these operating instructions. Approved accessories can be installed by specialist staff.

Each bicycle is assigned to a *bicycle type* which determines the proper use.

Safety

3.3.1



Mountain bike

A mountain bike is designed for sporting use on asphalted and non-asphalted paths. The design characteristics thus include a short wheelbase, a sitting position with the rider inclined towards the front, and a brake requiring low actuation force.

The strain on the rider, in particular the hands and wrists, arms, shoulders, neck and back, is accordingly high. Inexperienced riders tend to brake excessively and lose control as a result. A mountain bike is a piece of sporting equipment. It requires an adaptation period as well as physical fitness. Use requires the appropriate training; in particular riding in bends and braking should be practised.

3.4

Improper use

Failure to adhere to the proper use causes a risk of personal injury and material damage. The bicycle is not suitable for the following uses:

- riding with a damaged or incomplete bicycle,
- riding over steps,
- riding through deep water,
- lending the bicycle to untrained riders,
- carrying further passengers,
- riding with excessive luggage,
- riding with no hands,
- riding on ice and snow,
- improper servicing,
- improper repair,
- demanding areas of use, such as professional competition, and
- stunt riding or acrobatics.

3.5

Personal protective equipment

We recommend that you wear a suitable safety helmet. We also recommend that you wear typical, close-fitting cycling clothing and sturdy footwear.

3.6

Duty of care

The safety of the bicycle can only be assured if all the necessary measures are taken.

3.6.1

Rider

The rider:

- receives instruction before the first ride. He/she can clarify any questions relating to the operating instructions with the user or the HERCULES specialist dealer.
 - wears personal protective equipment.
- assumes all the obligations of the user in case the bicycle changes hands.

Safety

3.6.2

User

The user has the duty of care and responsibility for scheduling these measures and checking that they are implemented.

The user:

- makes these operating instructions available to the rider for the duration of use of the bicycle. If necessary, he translates the operating instructions into a language which the rider understands.
- familiarises the rider with the functions of the bicycle before the first ride. Only riders who have received instruction must be allowed to ride the bicycle.
- instructs the rider on proper use and the wearing of personal protective equipment.
- employs specialist staff only for maintenance and repair of the bicycle.

The printed EC declaration of conformity in the appendix is valid as long as the bicycle remains in original condition. As soon as the user makes any relevant modifications or additions, he legally becomes the manufacturer. He must independently guarantee compliance with the EC directives again in order to:

- circulate the bicycle again,
- apply the CE marking and
- avoid compromising occupational safety.

4 Description

4.1 Overview

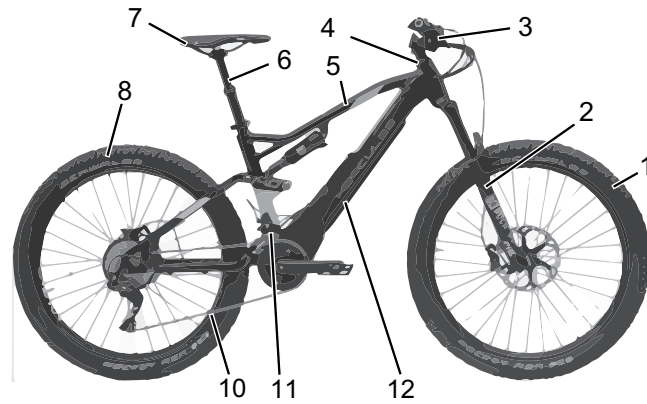

Figure 2:

Bicycle, viewed from the right, example of SNOS FS PRO

- 1 *Front wheel*
- 2 *Fork*
- 3 *Handlebars*
- 4 *Stem*
- 5 *Frame*
- 6 *Seat post*
- 7 *Saddle*
- 8 *Rear wheel*
- 9 *Chain*
- 10 *Frame number and type plate*
- 11 *Battery*

Description

4.2 Handlebars



Figure 3: Detailed view of bicycle from rider position, example

- 1 Rear brake lever
- 2 *Command console with display*
- 3 Front brake lever
- 4 Front shifter
- 5 Fork lock on *suspension fork head*
- 6 Rear shifter

4.3 Wheel and fork

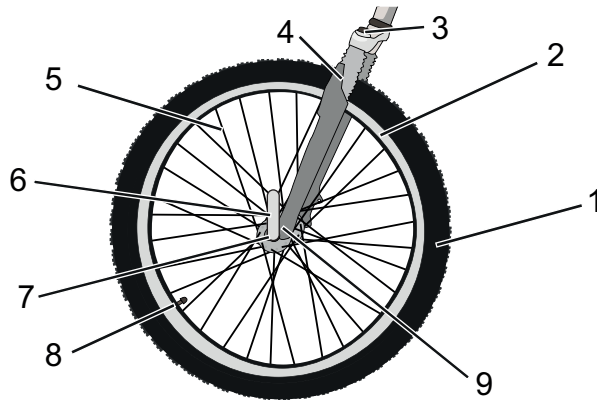

Figure 4:

Components of the wheel, example of front wheel

- | | |
|---|---|
| 1 | Tyre |
| 2 | Rim |
| 3 | Suspension fork head with setting wheel |
| 4 | Shock absorber |
| 5 | Spoke |
| 6 | Quick release |
| 7 | Hub |
| 8 | Valve |
| 9 | Fork end of the shock absorber |

4.3.1

Valve

Each wheel has a valve. It is used to fill the *tyre* with air. There is a valve cap on each valve. The screw-on valve cap keeps out dust and dirt.

The bicycle either has a classical *Dunlop valve*, a *Presta valve* or a *Schrader valve*.

Description

4.3.2 Suspension

A suspension fork has two functions which improve the floor contact and the comfort: the suspension and the damping.

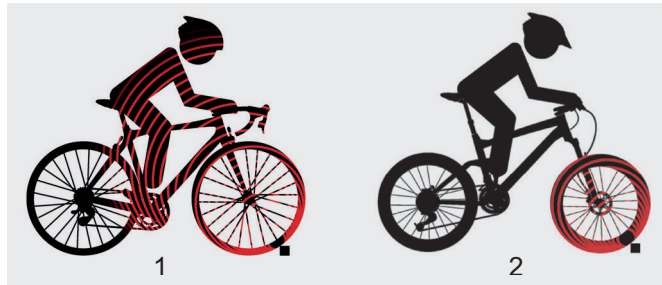

Figure 5: Bicycle without suspension (1) and with suspension (2) when riding over an obstacle

The suspension prevents an impact, e.g. caused by a stone lying in the way, from being directed directly into the rider's body via a fork. Instead, it is absorbed by the suspension system. This causes the suspension fork to compress. The compression can be disabled so that a suspension fork reacts like a rigid fork.

The compressed suspension fork then returns to its original position. The damper decelerates the movement and thus prevents the suspension system from springing back in an uncontrolled manner, and the fork from oscillating up and down.

Dampers which dampen the compressive deflection movements, i.e. the compression load, are called compression dampers or dashpots.

Dampers which dampen the rebound deflection movements, i.e. the rebound load, are called rebound dampers or dashpots.

Description

This model series features up to three different suspension and damping systems:

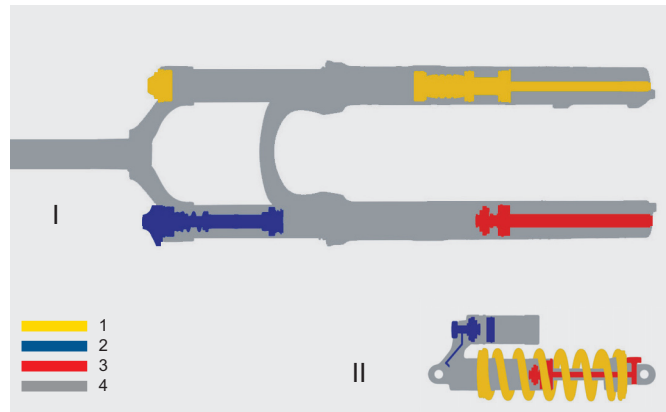

Figure 6:

Arrangement of the suspension systems for the front wheel (I) and rear wheel (II)

- 1 Rebound, suspension system (steel suspension fork or air suspension fork)
- 2 Compression damper
- 3 Rebound damper
- 4 Fork housing

Description

4.4 Brake system

The bicycle is equipped with a disk brake.

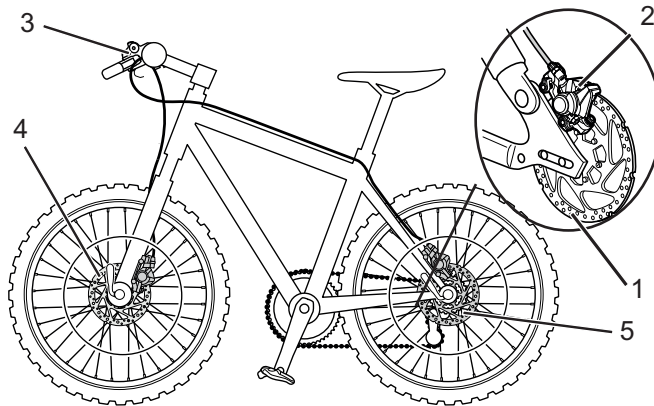

Figure 7: Bicycle brake system with a disk brake, example

- 1 Brake disk
- 2 Brake caliper with brake linings
- 3 *Handlebars with brake levers*
- 4 Front wheel brake disk
- 5 Rear wheel brake disk

On a bicycle with a disk brake, the brake disk is screwed permanently to the *hub* of the wheel. If the brake lever is pulled, the brake linings are pressed against the brake disk, and the movement of the wheel is stopped.

4.5 Electric drive system

The bicycle is driven by muscle power via the chain drive. The force which is applied by pedalling in the direction of travel, drives the front chain wheel. The chain transmits the force onto the rear chain wheel and then onto the rear wheel.

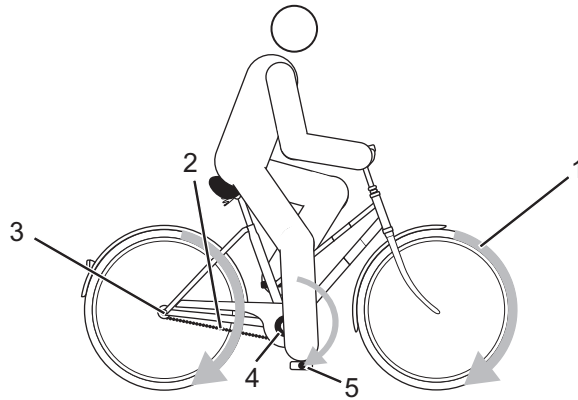

Figure 8:

Diagram of electric drive system

- 1 Direction of travel
- 2 Chain
- 3 Rear chain wheel
- 4 Front chain wheel
- 5 Pedal

The bicycle also has an integrated, electric drive system. The electric drive system is made of up to 8 components:

Description



Figure 9: Diagram of electric drive system

- 1 *Lamp*
 - 2 *Command console with display*
 - 3.1 *Pannier rack battery and/or*
 - 3.2 *Down tube battery*
 - 3.3 *Integrated battery*
 - 4 *Rear light*
 - 5 *Motor*
- a charger which is designed for this battery.

As soon as the required muscle power from the rider pedalling passes a certain level, the motor is activated gently and assists the pedalling motion of the rider. The motor force is determined by the set level of assistance.

Description

The bicycle does not have a separate emergency stop or emergency shut-off button. The drive system can be stopped in case of emergency by removing the *display*.

The motor switches off automatically as soon as the rider no longer pedals, the temperature is outside the permitted range, there is an overload or the shut-off speed of 25 km/h has been reached.

A pushing aid can be activated. The pushing aid continues to drive the bicycle as long as the rider pushes the plus button on the *handlebars*. The maximum speed can be 6 km/h here. The drive stops when the plus button is released.

4.5.1

Battery

The lithium ion battery has an internal electronic protection circuit. It is matched to the charger and the bicycle. The temperature of the battery is monitored constantly. The battery is safeguarded against deep discharge, overcharging, overheating and short circuit. In case of a risk the battery is switched off automatically by a protective circuit. The battery also switches to sleep mode for self-protection when not used for a longer period.

The service life of the battery can be extended if it is well cared for and, above all, stored at the correct temperatures. Even if the battery is cared for properly, the charge status of the battery reduces as it ages. If the operating time is severely shortened after charging, this is a sign that the battery is spent.

Description

Transportation temperature	5 °C - 25 °C
Ideal transportation temperature	10 °C - 15 °C
Storage temperature	5 °C - 25 °C
Ideal storage temperature	10 °C - 15 °C
Charging ambient temperature	10 °C - 30 °C

Table 16: Battery technical data

The bicycle has an integrated battery.



Figure 10: Integrated battery details

- 1 Locking lever
- 2 Operating and charge status indicator
- 3 Port for charger plug
- 4 Battery lock

Description

4.5.1.1**Operating and charge status indicator**

The five green LEDs of the operating and charge status indicator indicate the charge status of the battery when the battery is switched on. Each LED represents 20% of the charge status. The charge status of the activated battery is also shown on the *display*.

If the charge status of the battery is below 5%, all the LEDs of the operating and charge status indicator go out. However, the charge status is still shown on the *display*.

4.5.2**Running light**

When the running light is activated, the *lamp* and the rear light are switched on.

4.5.3**Display**

The *command console with display* controls the drive system with four operating elements, and displays the journey data.

The bicycle's battery supplies the command console with display with energy. The command console with display also has two internal non-rechargeable button cell batteries. This ensures that the system can be switched on using the command console with display.

Operating temperature	5 °C to 35 °C
------------------------------	---------------

Storage temperature	5 °C - 25 °C
----------------------------	--------------

Table 17:**Technical data for the command console with display**

The pane of glass on the display may steam up from the inside in the event of abrupt temperature fluctuations. This is not a malfunction.

Description

The command console with display has four buttons and a USB port.

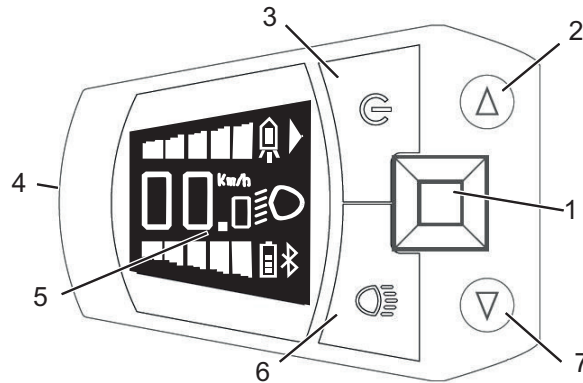

Figure 11:

Details of the command console with display

Symbols	Use
1	Joystick with menu navigation
2	▲ Level of assistance up button
3	⏻ On-Off button
4	USB port display
5	Display
6	💡 Lamp button
7	▼ Level of assistance down button

Table 18:

Overview of the command console with display

Description

4.5.3.1 USB port

There is a USB port underneath the rubber cover on the lower edge of the *display*.

Charge voltage	5 V
Charging current	max. 500 mA

Table 19: USB port technical data

4.5.3.2 Displays

The *display* has six different displays:

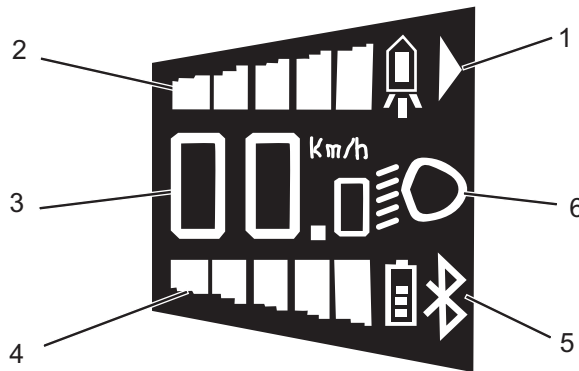

Figure 12: Overview of the displays

Use	
1	Pushing aid symbol
2	Level of assistance display
3	Function display
4	Battery charge status display
5	Bluetooth symbol
6	Running light symbol

Table 20: Overview of the screen display

Description

Level of assistance

The higher the selected level for assistance, the more the drive system assists the rider when pedalling. There are four levels of assistance available.

Display	Level of assistance
KEINE	Normal cycling conditions. The motor is not active.
ECO	Low level of assistance
NORMAL	Normal assistance
HIGH	Maximum assistance

Table 21:

Display of levels of assistance

Function display

The function display shows different information and functions:

- Journey information
- System messages and
- System functions.

Journey information

The main screen of the command console with display shows the current speed in km/h. The displayed screen can be changed using the joystick.





Display	Function
FAHRER LEISTUNG	 the current rider performance in watts
MOTORLEISTUNG	 the current motor performance in per cent of its maximum power
RESTREICHWEITE	 anticipated range of the available battery charge, calculated based on the most recent manner of riding
TOUR DISTANZ	 distance travelled since the last reset in km

Table 22:

Journey information

Description





Display	Function
Ø GESCHW.	 average speed since the last reset in km/h
MAX. GESCHW.	 maximum speed since the last reset in km/h
TOTAL DISTANZ	 total distance travelled
MAX.GESCHW.	 max. speed achieved

Table 22:

Journey information

System message

The drive system monitors itself continuously and if an error is detected, it is indicated by a system message. The system may switch off automatically depending on the type of error. There is a table of system messages in the Appendix.

System functions

The TOUR data and the Bluetooth connection are changed on the command console with display. The desired functions are called up using the joystick.



Display	Function
RESET	 resetting the TOUR data to zero
BLUETOOTH	 activating Bluetooth connectivity

Table 23:

System functions

Transportation, storage and assembly

5 Transportation, storage and assembly

5.1 Transportation



CAUTION

Crash caused by unintentional activation

There is a risk of injury if the drive system is activated unintentionally.

- ▶ Remove the battery before the bicycle is transported.
-



CAUTION

Risk of fire and explosion due to high temperatures

Excessively high temperatures damage the batteries. The batteries may self-ignite and explode.

- ▶ Never expose the battery to sustained direct sunlight.
-



NOTICE

If the bicycle is lying flat, oil and grease may leak from the bicycle.

If the shipping carton with a bicycle is lying flat or on one end, it does not provide sufficient protection from damage to the *frame* and the wheels.

- ▶ Only transport the bicycle in an upright position.
-



NOTICE

Bicycle rack systems which secure the bicycle standing on its head by the *handlebars* or *frame*, generate inadmissible forces on the components during transportation. This can cause the supporting parts to break.

- ▶ Never use bicycle rack systems which secure the bicycle standing on its head by the *handlebars* or *frame*.
-

Transportation, storage and assembly

- ▶ Take into account the weight of the roadworthy bicycle when transporting it.
- ▶ Protect the electrical components and connections on the bicycle from the elements with suitable protective covers.
- ▶ Remove accessories, for example drinking bottles, before transportation of the bicycle.
- ▶ When transporting by car, you must use a suitable bicycle rack system.



The HERCULES specialist dealer will advise you on how to select a suitable rack system properly and how to use it safely.

- ▶ Transport the bicycle in a dry, clean place which is protected from direct sunlight.



For shipping the bicycle, we recommend that you have the bicycle partially dismantled in the proper manner and packaged by the HERCULES specialist dealer.

Transportation, storage and assembly

5.2 Storing



Risk of fire and explosion due to high temperatures

Excessively high temperatures damage the battery. The battery may self-ignite and explode.

- ▶ Never expose the battery to sustained direct sunlight.



If the bicycle is lying flat, oil and grease may leak from the bicycle.

If the shipping carton with a bicycle is lying flat or on one end, it does not provide sufficient protection from damage to the *frame* and the wheels.

- ▶ Only store the bicycle in an upright position.
- ✓ Store the bicycle, battery and charger in a dry and clean place.

Storage temperature	5 °C - 25 °C
Ideal storage temperature	10 °C - 15 °C

Table 24:

Storage temperature for the battery, the bicycle and the charger

5.2.1 Break in operation



The battery discharges when it is not used. This can cause damage to the battery.

- ▶ The battery has to be recharged every 8 weeks.



The battery may become damaged if it is connected permanently to the charger.

- ▶ Do not connect the battery to the charger permanently.

If the bicycle is to be removed from service for longer than four weeks, e.g. in winter, a break in operation has to be prepared.

Transportation, storage and assembly

5.2.1.1

Preparing a break in operation

- ✓ Remove the battery from the bicycle.
- ✓ Charge the battery to around 60% (three to four LEDs of the charge status indicator light up).
- ✓ The bicycle has to be cleaned with a damp cloth and preserved with wax spray. Never wax the friction surfaces of the brake.
- ✓ Before longer periods without use, it is recommendable for the HERCULES specialist dealer to carry out servicing, basic cleaning and apply preservative agent.

5.2.1.2

Carrying out break in operation

- ▶ Store the bicycle, battery and charger in a dry and clean environment.
- ▶ Check the charge status of the battery after 8 weeks. If only one LED of the charge status indicator lights up, recharge the battery to around 60%.

Transportation, storage and assembly

5.3

Assembly



Crushing caused by unintentional activation

There is a risk of injury if the drive system is activated unintentionally.

- ▶ Remove the battery if the battery is not absolutely necessary for assembly.



- ✓ Assemble the bicycle in a clean and dry environment.
- ✓ The working environment should have a temperature of 15 °C - 25 °C.

Working environment temperature	15 °C - 25 °C
--	---------------

Table 25:

Working environment temperature

- ✓ If a fitting stand is used, it must be approved for a maximum weight of 30 kg.
- ✓ To reduce the weight, we recommend that you always disconnect the battery from the bicycle for the duration of use of the fitting stand.
- ✓ Universal tools, a torque spanner with an operating range of 5 Nm to 40 Nm and the special tools, as recommended by HERCULES GMBH, must be available.

5.3.1

Unpacking



Hand injuries caused by cardboard packaging

The shipping carton is closed with metal staples. There is a risk of puncture wounds and cuts when unpacking and crushing the packaging.

- ▶ Wear suitable hand protection.
- ▶ Remove the metal staples with pliers before the shipping carton is opened.

The packaging material consists mainly of cardboard and plastic film.

Transportation, storage and assembly

- ▶ The packaging has to be disposed of in accordance with the regulations of the authorities.

5.3.2

Scope of delivery

The bicycle was completely assembled in the factory for test purposes and then dismantled for transportation.

The scope of delivery includes:

- the bicycle, 98% pre-assembled,
- the front wheel,
- the battery or batteries,
- the charger,
- the pedals,
- the operating instructions.

5.3.3

Commissioning



Fire and explosion caused by incorrect charger

Batteries which are charged with an unsuitable charger, may become internally damaged. This may result in fire or an explosion.

- ▶ Only ever use the battery with the supplied charger.
- ▶ To prevent mix-ups, mark the supplied charger and these operating instructions clearly, for example with the *frame number* or *type number* of the bicycle.

Given that initial commissioning of the bicycle requires special tools and specialist knowledge, it must be performed by trained specialist staff only.

Experience has shown that a bicycle which has not yet been sold, is spontaneously handed to consumers as soon as it appears ready to ride.

- ▶ Every bicycle must be prepared so that it is in fully usable condition immediately after being set up.

Transportation, storage and assembly

Initial commissioning includes the following work:

- ▶ Check the battery [▷ *Chapter 5.3.3.1, page 45*].
- ▶ The battery is supplied partially charged. In order to guarantee full power, charge the battery fully.
- ▶ Remove the *command console with display* from the handlebars. Open the battery compartment cover and insert two button cell batteries. Re-install the display.
- ▶ Install the *wheels with quick release* and the *pedals*.
- ▶ Move the *handlebars* and *saddle* into the functional position.
- ▶ Check all the components to make sure that they are firmly in place.
- ▶ Check all the settings and the tightening torque of the axle nuts.

Axle nut tightening torque

35 Nm - 40 Nm

Table 26:

Axle nut tightening torque

- ▶ Check the entire cable harness to make sure that it is routed properly:
 - You must prevent the cable harness from coming into contact with moving parts.
 - The cable routes must be smooth and free from sharp edges.
 - Moving parts must not apply any pressure or tension to the cable harness.
- ▶ Set the *lamp*.
- ▶ Check the drive system, the light equipment and the brakes to make sure that they are fully functional and effective.
- ▶ Set the drive system has to the national language and the appropriate system of measurement.
- ▶ Check the software version of the drive system and update it as necessary.

Sale of the bicycle

- ▶ Fill out the data sheet on the first page of the operating instructions.
- ▶ Adjust the bicycle to the rider.
- ▶ Set the *kickstand* and the *shifter*, and show the purchaser the settings.
- ▶ Instruct the user or rider how to use all the functions of the bicycle.

5.3.3.1

Checking the battery

The battery has to be checked before it is charged for the first time.

- ▶ Press the *On-Off button (battery)*.
- ⇒ If none of the LEDs on the operating and charge status indicator light up, the battery may be damaged.
- ⇒ If at least one of the LEDs of the operating and charge status indicator lights up, but not all of them, the battery can be charged.

5.3.4

Installing the wheels with quick release



Crash caused by unfastened quick release

A faulty or incorrectly installed quick release may become caught in the brake disk and block the wheel. This will cause a crash.

- ▶ Install the front wheel quick release lever on the opposite side to the brake disk.

Transportation, storage and assembly



Crash caused by faulty or incorrectly installed quick release

The brake disk becomes very hot during operation. Parts of the quick release may become damaged as a result. The quick release comes loose. This will result in a crash and injuries.

- ▶ The front wheel quick release lever and the brake disk must be situated on opposite sides.



Crash caused by incorrectly set clamping force

Excessively high clamping force will damage the quick release and cause it to lose its function.

Insufficient clamping force will cause a detrimental transmission of force. The suspension fork or the frame may break. This will result in a crash and injuries.

- ▶ Never fasten a quick release using a tool (e.g. hammer or pliers).
- ▶ Only use the clamping lever with the specified set clamping force.

- ▶ Open the clamping lever.
- ▶ Push the opened clamping lever with the wheel axle from the right-hand side through the hub.
- ▶ Clamp the wheel and set the clamping force, depending on the version.

6 Adjusting the bicycle to the rider



The HERCULES specialist dealer checks all the factory settings and, when the bicycle is sold, adapts the settings of the *saddle*, *handlebars*, *suspension fork* and the *spring damper element* to the rider.

6.1 Adjusting the saddle

6.1.1 Determining the seat height



Crash caused by an excessively high seat post setting

A *seat post* which is set too high will cause the *seat post* or the *frame* to break. This will result in a crash and injuries.

- ▶ Do not pull the seat post out of the frame beyond the minimum insertion depth marking.

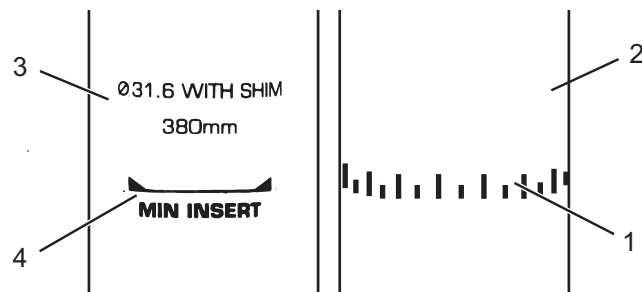

Figure 13:

Detailed view of the seat post, examples of the minimum insertion depth marking

- 1 III marking for minimum insertion depth
- 2 Seat post I
- 3 Seat post II
- 4 MIN marking for minimum insertion depth

Adjusting the bicycle to the rider

From an ergonomic point of view, the seat height should be set so that the heel touches the lowest point of the pedal when the leg is outstretched.

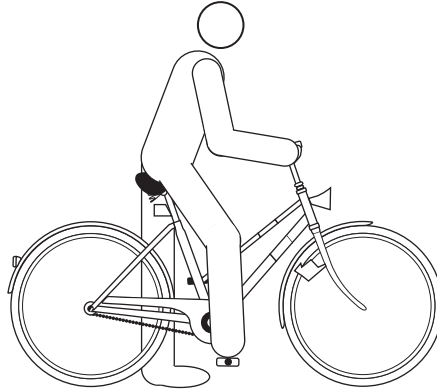

Figure 14: Determining the saddle height

6.1.2



Clamping the seat post with the quick release

The HERCULES specialist dealer demonstrates the function of the quick release to the rider or user.



Figure 15: Seat post quick release in the final position

- 1 Seat post clamping lever
- 2 Seat post
- 3 Knurled nut

Adjusting the bicycle to the rider

Clamping

- ✓ Only clamp the *seat post* when the bicycle is stationary.

The *seat post clamping lever* is not marked with any lettering. You can tell whether it is open or closed from its shape.

- To close it, push the *seat post clamping lever* as far as it will go into the *seat post*.
- To open it, pull the *seat post clamping lever* away from the *seat post*.

▶ Check the *clamping force of the quick releases*.

6.1.3



Adjusting the sitting position and saddle tilt

Special tools are required to adjust the seat length and the saddle tilt. The HERCULES specialist dealer adjusts the saddle setting to the rider.

6.2



Setting the handlebars

- ✓ The handlebars setting must only be made while the bicycle is stationary.
- ▶ Unfasten and adjust the designated screw connections, and clamp them with the maximum tightening torque for the clamping screws of the handlebars.

Maximum tightening torque for the clamping screws of the handlebars*

5 Nm - 7 Nm

*if there is no other data on the component

Table 27:

Handlebars clamping screw maximum tightening torque

Adjusting the bicycle to the rider

6.3 Setting the stem with quick release (Alternative version)



Crash caused by incorrectly set clamping force

Excessively high clamping force will damage the quick release and cause it to lose its function.

Insufficient clamping force will cause a detrimental transmission of force. This can cause components to break. This will result in a crash and injuries.

- ▶ Never fasten a quick release using a tool (e.g. hammer or pliers).
 - ▶ Only use the clamping lever with the specified set clamping force.
-
- ▶ Open the clamping lever for the quick release on the stem.
 - ▶ Pull the locking lever on the stem up, and simultaneously pivot the handlebars into the desired position.
 - ⇒ You feel the locking lever click into place.
 - ▶ Pull out the handlebars to the required height.
 - ▶ Lock the quick release.
 - ▶ Check the clamping force of the quick releases.



Figure 16: Closed clamping lever (2) with knurled nut (3) and locking lever (1) on the stem

6.4

Checking the clamping force of the quick releases

- ▶ Open and close the quick releases on the stem or the seat post.
- ⇒ The clamping force is sufficient if the clamping lever can be moved easily from the open final position into the middle and has to be pressed with the fingers or base of the thumb from the middle point onwards.

Setting the clamping force

- ▶ If the *clamping lever on the handlebars* cannot be moved into its final position, screw out the *knurled nut*.
- ▶ If the clamping force of the *clamping lever on the seat post* is not sufficient, screw in the *knurled nut*.



If the clamping force cannot be set, the HERCULES specialist dealer will need to check the quick release.

6.5

Basic setting for suspension and damping

The adjustment shown here represents a basic setting. The rider should change the basic setting to suit the surface and his/her preferences.

- ▶ It is recommendable to make a note of the basic setting. This way, it can be used as the starting point for subsequent, optimised settings and to safeguard against unintentional changes.

Adjusting the bicycle to the rider

6.5.1 Adjusting the hardness of the spring elements

6.5.1.1 Adjusting the hardness of the steel suspension fork

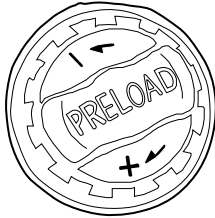

Figure 17:

Suspension fork setting wheel, example

- ▶ Use the *setting wheel* on the left-hand *suspension fork head* to adjust the hardness of the steel suspension fork. Adjust the hardness of the steel suspension fork by turning the *setting wheel* in the plus or minus direction.
- ⇒ The ideal setting in relation to the weight of the rider has been achieved when the shock absorber deflects 3 mm under the stationary load of the rider.
- ▶ If applicable, re-attach the plastic cover after setting the suspension fork.

Adjusting the bicycle to the rider

6.5.1.2

Adjusting the hardness of the air suspension elements

NOTICE

Riding without filling pressure will destroy the wheel suspension, the frame and the air suspension elements.

- ▶ Never ride without filling pressure in the air suspension elements.

NOTICE

A normal air pump cannot build up the required pressure with sufficient sensitivity.

- ▶ Use a special damper pump to adjust the filling pressure.

6.5.1.3



Front wheel

- ✓ Only make the air suspension fork setting with the bicycle stationary.
- ▶ The fork valve is located underneath a screw cover on the head of the left-hand fork tube. Unscrew and remove the screw cover.

Figure 18:

Fork valve, example

- ▶ Set the filling pressure using the filling pressure recommendations on the air suspension fork as the initial value.
- ▶ Set the O-rings on the stanchion or the piston to the minimum possible deflection.
- ▶ Sit on the bicycle and dismount again.
- ▶ Read the position of the displaced O-ring.
- ⇒ The ideal setting for the weight of the rider has been achieved when the measured position is between 20 - 30%.
- ▶ For fine setting, adjust the filling pressure using the fork valve.
- ▶ Screw the screw cover back on.

Adjusting the bicycle to the rider

Rear wheel

- ▶ Unscrew the valve cap from the rear wheel damper valve.
 - ▶ Push the O-ring on the dial directly onto the housing of the suspension damping element.
 - ▶ Sit on the bicycle and dismount again.
 - ▶ Read the position of the displaced O-ring.
- ⇒ The ideal setting for the weight of the rider has been achieved when the measured position is between 20 - 30%.
- ▶ If the setting is incorrect, adjust the filling pressure using the suspension damping element valve:
 - If the pressure is too high, let out air
 - If the pressure is too low, carefully pump up the suspension damping element.
 - ▶ Screw the valve cap back on.



Figure 19:

Setting the hardness on the suspension damping element

- 1 Dial
- 2 Valve cap on suspension damping element
- 3 O-ring

6.5.2 Setting the rebound damper

Front wheel

- ▶ The rebound damper for the front wheel is situated on the fork leg. It may be marked with either hare/tortoise symbols or plus and minus symbols.



Figure 20:

Setting the rebound damper, example with hare and tortoise symbol

- | | |
|---|-----------------|
| 1 | Setting bolt |
| 2 | Tortoise symbol |
| 3 | Suspension fork |
| 4 | Hare symbol |

- ▶ Open the rebound damper completely. To do so, turn the setting bolt all the way towards the hare symbol or the minus symbol.
 - ▶ Stand next to the bicycle. Deflect the fork as far as possible by pushing down the handlebars.
 - ▶ Release the handlebars abruptly.
- ⇒ The ideal setting for the rebound damper has been achieved when the wheel maintains contact with the floor when springing back.

Adjusting the bicycle to the rider

- ▶ If the wheel loses contact with the floor, turn back in small steps towards the tortoise symbol or plus symbol.

Rear wheel

The rebound damper for the rear wheel is situated on the suspension damping element.



Figure 21:

Setting the hardness on the suspension damping element

- 1 Setting wheel
- 2 Hare symbol
- 3 Tortoise symbol

- ▶ Set the setting wheel to the middle position between the hare and the tortoise symbols.
- ▶ Ride over a small obstacle with the bicycle.
- ⇒ The ideal setting for the rebound damper has been achieved when the rebound movement of the rear wheel feels comparable to that of the front wheel.
- ▶ If the rear wheel springs much quicker or slower than the front wheel, change the setting by turning the setting wheel.

Adjusting the bicycle to the rider

6.5.3 Setting the compression damper

The basic setting only has to be determined for compression dampers which have to be set with multiple clicks. A setting of 5 clicks is recommended as the basic setting.

Response of the damper	Setting
sensitive	select opened damping or low pressure level
soft or delayed	moderately closed pressure level

Table 28: Setting the compression damper

- ▶ Set the ideal basic setting using the locking lever.



Figure 22: Compression damper with locking lever (1), example

Adjusting the bicycle to the rider

6.6 Setting the grip distance of the brake lever

- ▶ Set the grip distance using the knurled screw on the brake lever.
- ⇒ The rider can use the brake lever comfortably.

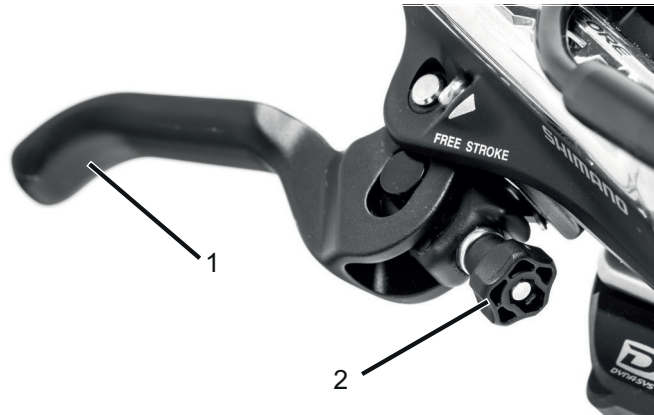

Figure 23: Brake lever (1) with knurled screw (2)

7 Operation



Crash caused by loose clothing

Laces, scarves and other loose items may become entangled in the spokes on the *wheels* and the *chain drive*. This may result in a crash and injuries.

- ▶ Wear sturdy footwear and close-fitting clothing.



Crash caused by soiling

Heavy soiling can impair the functions of the bicycle, for example, the function of the brakes. This may result in a crash and injuries.

- ▶ Remove coarse soiling before riding.



Crash caused by poor road conditions

Loose objects, for example, branches and twigs, may become caught in the wheels and cause a crash.

- ▶ Be aware of the road conditions.
- ▶ Ride slowly and brake in good time.

NOTICE

When riding downhill, high speeds may be reached. The bicycle is only engineered for exceeding a speed of 25 km/h briefly. In particular the *tyres* can fail if exposed to a continuous load.

- ▶ Decelerate the bicycle with the brakes if higher speeds than 25 km/h are reached.

NOTICE

Heat or direct sunlight can cause the *tyre pressure* to increase above the permitted maximum pressure. This can destroy the *tyres*.

- ▶ Never park the bicycle in the sun.
- ▶ On hot days, regularly check the *tyre pressure* and adjust it as necessary.

Operation

The bicycle can be ridden within a temperature range of 5 °C - 35 °C. The effectiveness of the drive system is restricted outside of this temperature range.

Operation temperature 5 °C - 35 °C

As a result of the open construction, penetration from moisture at cold temperatures may impair individual bicycle functions.

- ▶ Always keep the bicycle dry and free from frost.
- ▶ If the bicycle is to be operated at temperatures below 3 °C, the HERCULES specialist dealer must first prepare the bicycle for winter service.



Off-road riding subjects the joints in the arms to severe strain. Take a break from riding every 30 to 90 minutes, depending on the condition of the roads.

7.1 Before each ride



Crash caused by unidentified damage

After a crash, accident or if the bicycle falls over, there may be barely identifiable damage, e.g. to the brake system, the quick releases or the *frame*. This may result in a crash and injuries.

- ▶ Remove the bicycle from service and have a HERCULES specialist dealer carry out an inspection.



Crash caused by material fatigue

A component may suddenly fail in case of material fatigue. This may result in a crash and injuries.

Remove the bicycle from service immediately in case of any signs of material fatigue. Have the HERCULES specialist dealer check the situation.

- ▶ Have the HERCULES specialist dealer carry out basic cleaning regularly. During basic cleaning, the HERCULES specialist dealer inspects the bicycle for any signs of material fatigue.

- ▶ Check the bicycle before each ride.

⇒ In case of any discrepancies from the *Check list before each ride*, or any anomalies of any kind, the bicycle must not be used until the cause has been clarified.

Operation

Check list before each ride

<input type="checkbox"/>	Check that the bicycle is complete.
<input type="checkbox"/>	Check that the lighting, reflector and brake, for instance, are sufficiently clean.
<input type="checkbox"/>	You must check that the mudguards, the pannier rack and the chain guard are securely installed.
<input type="checkbox"/>	Check that the front and rear wheels run true. This is particularly important if the bicycle has been transported or secured with a lock.
<input type="checkbox"/>	Check the valves and the tyre pressure. Adjust as necessary before each ride.
<input type="checkbox"/>	Check the front and rear wheel brakes to make sure that they are working properly. To do so, operate the brake levers while the bicycle is stationary in order to check whether resistance is generated in the usual brake lever position.
<input type="checkbox"/>	Check that the running light is working.
<input type="checkbox"/>	Check for unusual noises, vibrations, smells, discolouration, deformation, abrasion and wear. This indicates material fatigue.
<input type="checkbox"/>	Be alert to any unusual operating sensations when braking, pedalling or steering.
<input type="checkbox"/>	Check the quick releases to make sure that they are fully closed in their final position.
<input type="checkbox"/>	On a bicycle with a hydraulic rim brake, check whether the locking levers are fully closed in their final positions.

7.2 Using the kickstand



Crash caused by a lowered kickstand

The kickstand does not fold up automatically. There is a risk of crashing if riding with the kickstand lowered.

- ▶ Raise the kickstand completely before the ride.

NOTICE

Because of the heavy weight of the bicycle, the kickstand may sink into soft ground, the bicycle may topple and fall over.

- ▶ The bicycle must only be parked on level, firm ground.
- ▶ It is particularly important to check the stability if the bicycle is equipped with accessories or loaded with luggage.

Raising the kickstand

- ▶ Before the ride, raise the kickstand completely with your foot.

Parking the bicycle

- ▶ Before parking, lower the kickstand completely with your foot.
- ▶ Park the bicycle carefully and check that it is stable.

Operation

7.3 Battery



WARNING

Risk of fire and explosion due to faulty battery

The safety electronics on damaged or faulty batteries may fail. The residual voltage can cause a short circuit. The batteries may self-ignite and explode.

- ▶ Remove batteries with external damage from service immediately and never charge them.
- ▶ If the battery becomes deformed or begins to smoke, keep at a safe distance, disconnect the power supply at the socket, and notify the fire service immediately.
- ▶ Never extinguish damaged batteries with water or allow them to come into contact with water.
- ▶ If a battery is dropped or struck but shows no signs of external damage, remove the battery from service and observe it for at least 24 hours.
- ▶ Faulty batteries are hazardous goods. Dispose of faulty batteries properly and as quickly as possible.
- ▶ Store in a dry place until disposal. Never store in the vicinity of flammable substances.
- ▶ Never open or repair the battery.



CAUTION

Risk of fire and explosion due to high temperatures

Excessively high temperatures damage the battery. The battery may self-ignite and explode.

- ▶ Never expose the battery to sustained direct sunlight.

**Fire and explosion caused by short circuit**

Small metal objects may jumper the electrical connections of the battery. The batteries may self-ignite and explode.

- ▶ Keep paper clips, screws, coins, keys and other small parts away from the battery and do not insert them into the battery.

**Chemical burns to the skin and eyes caused by faulty battery**

Liquids and vapours may leak from damaged or faulty batteries. They can irritate the airways and cause burns.

- ▶ Avoid contact with leaked liquids.
- ▶ Immediately consult a doctor in case of contact with the eyes or any discomfort.
- ▶ In case of contact with the skin, rinse off immediately with water.
- ▶ Ventilate the room well.

**Fire and explosion caused by penetration by water**

The battery is only protected from simple spray water. Penetration by water can cause a short circuit. The battery may self-ignite and explode.

- ▶ Never immerse the battery in water.
- ▶ If there is reason to believe that water may enter into the battery, the battery must be removed from service.

Operation

NOTICE

If a key is left inserted when transporting the bicycle, or when riding, it may break off or the compartment may open accidentally.

- ▶ Remove the key from the battery lock immediately after use.
- ▶ We recommend that you attach the key to a key ring.

✓ Before the battery is to be removed or inserted, switch off the battery and the drive system.

7.3.1

Removing the integrated battery

- ▶ Open the battery lock with the key.
 - ▶ Remove the key from the lock.
 - ▶ Support the battery from below with your hand.
 - ▶ Using the other hand, shift the *locking lever* upwards as far as it will go.
- ⇒ The integrated battery is released and falls into your hand.

7.3.2

Inserting the integrated battery

- ▶ Pivot the battery into the frame top first.
- ▶ Shift the *locking lever* downwards as far as it will go.
- ▶ Lock the battery with the key. Otherwise the battery may fall out of the mount when you open the lock.
- ▶ Remove the key from the lock.
- ▶ Check the inserted battery to make sure it is firmly in place.

7.3.3 Charging the battery



Fire caused by overheated charger

The charger heats up when charging the battery. In case of insufficient cooling, this can result in fire or burns to the hands.

- ▶ Never use the charger on a highly flammable surface (e.g. paper, carpet etc.).
- ▶ Never cover the charger during the charging process.



Electric shock caused by penetration by water

If water penetrates into the charger, there is a risk of electric shock.

- ▶ Never charge the battery outdoors.



Electric shock in case of damage

Damaged chargers, cables and plug connectors increase the risk of electric shock.

- ▶ Check the charger, cable and plug connector before each use. Never use a damaged charger.
- ▶ The ambient temperature during the charging process must be within the range from 10 °C to 30 °C.

Charging temperature 10 °C - 30 °C

- ✓ The battery can remain on the bicycle or be removed for charging.
- ✓ Interrupting the charging process does not damage the battery.
- ✓ On a bicycle which is equipped with two batteries, the charging process for both batteries is started from the pannier rack battery.

Operation

- ▶ Remove the rubber cover from the battery.
- ▶ Connect the mains plug of the charger to a normal domestic, grounded socket.

Connection data	230 V, 50 Hz
------------------------	--------------

- ▶ Connect the charging cable to the battery's charging port.
- ⇒ The charging process starts automatically.
- ⇒ During the charging process the operating and charge status indicator indicates the charge status. When the drive system is switched on, the *display* shows the charging process.
- ⇒ The charging process is complete when the LEDs of the operating and charge status indicator go out.

CAUTION **Risk of fire and explosion caused by damaged batteries.** The safety electronics on damaged or faulty batteries may fail. The residual voltage can cause a short circuit. The batteries may self-ignite and explode. If the battery becomes deformed or begins to smoke, keep at a safe distance, disconnect the power supply at the socket, and notify the fire service immediately. Never extinguish damaged batteries with water or allow them to come into contact with water.

NOTICE If an error occurs during the charging process, a system message is displayed. Remove the charger and the battery from operation immediately and follow the instructions.

7.3.4

Waking the battery

- ✓ When not used for a longer period, the battery switches to sleep mode for self-protection. The LEDs of the operating and charge status indicator do not light up.
- ▶ Press the *On-Off button (battery)*.
- ▶ The battery's operating and charge status indicator indicates the charge status.

Operation

7.4 Electric drive system

7.4.1 Switching on the drive system



Crash caused by lack of readiness for braking

A drive system which has been switched on can be activated by the application of force on the pedals. There is a risk of a crash if the drive is activated unintentionally, and the brake is not reached.

- ▶ Never start the electric drive system, or switch it off immediately, if the brake cannot be reached safely and reliably.
-

- ✓ A sufficiently charged battery has been inserted on the bicycle.
- ✓ The battery is firmly in place. The key has been removed.
- ✓ After switching off, the drive system shuts down. It is possible to switch back on immediately. Wait a moment as necessary.

There are two options for switching on the drive system.

1 Battery On-Off button

- ▶ Press the **On-Off button (battery)** once.

2 On-Off button, command console with display

- ▶ Press the **On-Off button (command console with display)** for longer than 0.5 seconds and max. 2 seconds.
- ⇒ If the drive system is switched on, the drive is activated as soon as the pedals are moved with sufficient force.

7.4.2

Switching off the drive system

The system switches off automatically ten minutes after the last command. There are two options for switching off the drive system manually.

1 On-Off key, command console with display

- ▶ Press the **On-Off button (command console with display)** once.

2 Battery On-Off key

- ▶ Press the **On-Off button (command console with display)** for longer than 2 seconds.

Operation

7.5 Command console with display

7.5.1 Using the pushing aid



CAUTION

Fall caused by strong acceleration

If the pedals are pressed with a pushing aid activated, the bicycle accelerates strongly. This may result in a crash and injuries.

- ▶ Never mount the bicycle with the pushing aid activated.
-

NOTICE

The pedals turn when using the pushing aid because of the design.

- ▶ When the pushing aid is in use, the bicycle must be steered securely with both hands.
 - ▶ Allow for enough freedom of movement for the pedals.
 - ▶ Never use a pushing aid for slow riding.
-

The pushing aid provides the rider with assistance when pushing the bicycle. The maximum speed can be 6 km/h here.

- ▶ Press and hold the **level of assistance up button** for longer than three seconds.
- ⇒ The pushing aid is activated. The *pushing aid symbol* is displayed.
- ▶ Release the *plus button* to shut off the pushing aid.

7.5.2

Using the running light

- ✓ To switch on the *running light*, the drive system has to be switched on already.
- ▶ Press the **lamp button** briefly.
- ⇒ The *running light* is switched on, and the *running light symbol* is displayed.
- ▶ Press and hold the **lamp button** for longer than two seconds.
- ⇒ The *running light* is switched off, and the *running light symbol* is not displayed.

7.5.3

Using the main beam (Alternative equipment)

- ✓ To switch on the *main beam*, the running light has to be switched on already.
- ▶ Press the **lamp button** briefly.
- ⇒ The *main beam* is switched on, and the *main beam symbol* is displayed.
- ▶ Press the **lamp button** briefly.
- ⇒ The *main beam* is switched off, and the *running light symbol* is displayed.

7.5.4

Selecting the level of assistance

- ▶ Press the **level of assistance up button**.
- ⇒ The level of assistance is increased.
- ▶ Press the **level of assistance down button**.
- ⇒ The level of assistance is reduced.

Operation

7.5.5 Journey information

The displayed *journey information* can be changed and partially reset.

7.5.5.1 Switching the displayed journey information

- ▶ Move the joystick forwards or backwards until the desired *journey information* is displayed.
 - ▶ Press the joystick.
- ⇒ The desired journey information is activated and is shown on the display.

7.5.5.2 Resetting all values in TOUR menu

- ▶ Move the **joystick** to the right again until the desired *journey information* TOUR-MENÜ is displayed.
 - ▶ Move the **joystick** downwards until the desired *journey information* RESET is displayed.
 - ▶ Press the **joystick** in its centre position.
- ⇒ All values in the TOUR-MENÜ have been reset.

7.5.6 Using the USB port

The USB port can be used to operate external devices which can be connected using a standard micro A/micro B USB 2.0 cable.

- ▶ Open the protective flap on the USB port.
- ▶ Replace the protective flap after using the USB port.

NOTICE Any moisture which enters through the USB port may trigger a short circuit in the *display*. Regularly check the position of the rubber cover on the USB port and adjust it as necessary.

7.5.7 Using Bluetooth connection

An active Bluetooth connection can establish a connection to external devices. This enables data exchange.

7.5.7.1 Activating Bluetooth connectivity

- ▶ Select the journey information BLUETOOTH.
- ▶ Select the device type to be used for data exchange. The user can choose between SMARTPHONE or BRUSTGURT (chest strap).
- ▶ Go to the main screen.
- ⇒ Connect the Bluetooth device to the control unit. For this, follow the instructions on the Bluetooth device.
- ⇒ The control unit exchanges data with the Bluetooth device. It may take a while to establish the connection.

7.5.7.2 Deactivating Bluetooth connectivity

- ▶ Select the journey information BLUETOOTH.
- ▶ Activate AUS option (off).
- ⇒ The control unit no longer transmits signals. Bluetooth connectivity is cancelled.

Operation

7.6

Gear shift

The selection of the appropriate gear is a prerequisite for a physically comfortable ride and making sure that the electric drive system functions properly. The ideal pedalling frequency is between 40 and 60 revolutions per minute.

- ▶ Select the appropriate gear with the *gear shift shifter*.
- ⇒ The gear shift switches the gear.

7.7

Brakes



Crash caused by incorrect use

Handling the brake improperly can lead to loss of control or crashes, which may result in injuries.

- ▶ Practise braking and emergency braking before the bicycle is used in public spaces.
- ▶ Shift your weight back and down as far as possible.



Crash caused by wet conditions

The *tyres* may slip on wet roads. In wet conditions you must also expect a longer braking distance. The braking sensation differs from the usual sensation. This can cause loss of control or a crash, which may result in injuries.

- ▶ Ride slowly and brake in good time.



Crash after cleaning, servicing or repair

After cleaning, servicing or repairing the bicycle, the braking effect may be temporarily unusually weak. This may result in a crash and injuries.

- ▶ After cleaning, servicing or repair, carry out a few test brake applications.



Burns caused by heated brake

The brakes may become very hot during operation. There is a risk of burns in case of contact.

- ▶ Never touch the components of the brake directly after the ride.

Operation

The drive force of the motor is shut off during the ride as soon as the rider no longer pedals. The drive system does not switch off when braking.

- ▶ In order to achieve optimum braking results, do not pedal while braking.

7.7.1

Using the brake

- ▶ Pull the *brake levers* until the desired speed has been reached.

7.8 Suspension and damping

7.8.1 Locking the front wheel suspension (Alternative equipment)

When the *fork lock* is in the open position, the *suspension system* has activated suspension and thus provides the rider and the bicycle with relief. Riding with the *fork lock* open should therefore be preferred for everyday riding.

When riding downhill or at high speed, for instance, the force which is exerted on the drive is absorbed by the *suspension system* and reduced by up to 50%. In these cases it is recommendable to close the suspension fork.

The *fork lock* may be situated directly on the fork or on the handlebars, depending on the version.

7.8.1.1 Fork lock on the suspension head

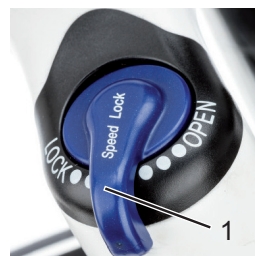

▶ In order to lock the *front wheel suspension*, shift the *locking lever* to the LOCK position.

▶ In order to release the *front wheel suspension*, shift the *locking lever* to the OPEN position.

Figure 24: Fork lock on the suspension for head with locking lever (1), example

Operation

7.8.1.2

Fork lock on handlebars, version I

- ▶ To lock the *suspension system*, push the locking slider out of the pushed-in position.
- ⇒ The locking slider stops in the pushed-out position. A padlock symbol indicates that the fork lock is locked.



- ▶ To release the *front wheel suspension*, push the locking slider out of the pushed-out position.
- ⇒ You can tell that the fork lock is open if the locking slider is pushed in.

Figure 25:

Fork lock on handlebars, version I, with locking slider (1)

7.8.1.3

Fork lock on handlebars, version II

- ▶ To lock the *suspension system*, push the black locking lever. The locking lever features a closed padlock symbol.

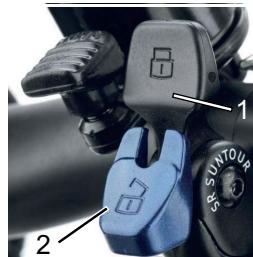

- ▶ To release the *front wheel suspension*, push the blue unlocking lever.
- ⇒ The unlocking lever features an open padlock symbol.

Figure 26:

Fork lock on handlebars, version II, with locking lever (1) and unlocking lever (2) (example)

7.8.1.4 Fork lock on handlebars, version III

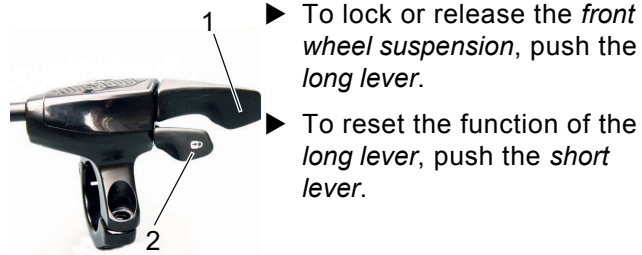

Figure 27: Fork lock on handlebars, version III, with long lever (1) and short lever (2), example

7.8.1.5 Fork lock on handlebars, version IV

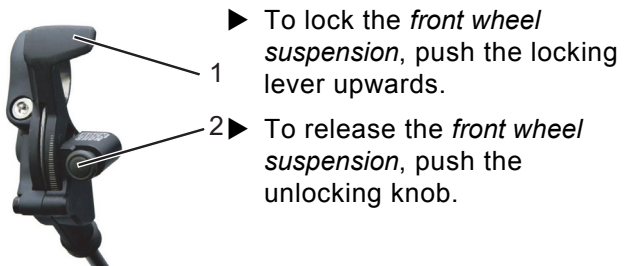

Figure 28: Fork lock on handlebars, version IV, with locking lever (1) and unlocking knob (2)

Operation

7.8.1.6

Fork lock on handlebars, version V

- ▶ To lock the *front wheel suspension*, push the upper locking lever.
- ⇒ The locking lever features a closed padlock symbol.



- ▶ To release the *front wheel suspension*, push the side unlocking lever.
- ⇒ The side unlocking lever features an open padlock symbol.

Figure 29:

Fork lock on handlebars, version V, with locking lever (1) and unlocking lever (2)

7.8.2

Locking the compression damper



- ▶ In order to lock the suspension, turn the locking lever in the plus direction.
- ▶ In order to release the suspension, turn the locking lever in the minus direction.

Figure 30:

Compression damper with locking lever (1), example

8 Maintenance

Cleaning check list

<input type="checkbox"/>	Lubricating the chain	once a month
<input type="checkbox"/>	Cleaning the battery	once a month
<input type="checkbox"/>	Basic cleaning and preservation of all components	at least every six months
<input type="checkbox"/>	Cleaning the charger	at least every six months

Maintenance check list

<input type="checkbox"/>	Checking the position of the USB rubber cover	before each ride
<input type="checkbox"/>	Checking for tyre wear	once a week
<input type="checkbox"/>	Checking for rim wear	once a week
<input type="checkbox"/>	Checking the tyre pressure	once a week
<input type="checkbox"/>	Checking for brake wear	once a month
<input type="checkbox"/>	Checking the electrical cables and Bowden cables for damage and to make sure they are fully functional	once a month
<input type="checkbox"/>	Checking the chain tension	once a month
<input type="checkbox"/>	Checking the tension of the spokes	every three months
<input type="checkbox"/>	Checking the gear shift setting	every three months
<input type="checkbox"/>	Checking the suspension fork for wear and to make sure it is fully functional	every three months

Service check list

<input type="checkbox"/>	Service by the specialist dealer	every six months
--------------------------	----------------------------------	------------------

Maintenance

8.1 Cleaning and servicing



Crash and falling caused by unintentional activation

There is a risk of injury if the drive system is activated unintentionally.

- ▶ Remove the battery before cleaning.
-

The following servicing measures must be carried out regularly [▶ *Check list, page 83*]. Servicing can be performed by the user and rider. In case of any doubt, consult the HERCULES specialist dealer.

8.1.1 Battery



Fire and explosion caused by penetration by water

The battery is only protected from simple spray water. Penetration by water can cause a short circuit. The battery may self-ignite and explode.

- ▶ Never clean the battery with a high-pressure water device, water jet or compressed air.
 - ▶ Never immerse the battery in water.
 - ▶ Remove the battery from the bicycle before cleaning.
-

- ▶ Only clean the electrical connections of the battery with a dry cloth or brush.
 - ▶ Wipe off the decorative sides with a damp cloth.
-

8.1.2 Display

- ▶ Carefully clean the *display* with a damp, soft cloth.

8.1.3 Basic cleaning and preservation



Crash caused by brake failure

After cleaning, servicing or repairing the bicycle, the braking effect may be temporarily unusually weak. This may result in a crash and injuries.

- ▶ Never apply care products or oil to the brake disks or brake pads, or the braking surfaces on the *rims*.
- ▶ After cleaning, servicing or repair, carry out a few test brake applications.

NOTICE

Water may enter into the inside of the bearings if you use a steam jet. The lubricant inside is diluted, the friction increases and, as a result, the bearings are destroyed in the long term.

- ▶ Never clean the bicycle with a steam jet.

NOTICE

Greased parts, e.g. the *seat post*, the *handlebars* or the *stem*, may no longer be safely and reliably clamped.

- ▶ Never apply grease or oil to the clamping areas.
- ▶ Clean the bicycle with a damp cloth. Mix a little neutral soap with the cleaning water.
- ▶ Then use wax or oil on the bicycle as a preservative agent.

8.1.4 Chain

- ▶ Clean and lubricate the *chain* and the *chain wheels* using the stipulated care products.

Maintenance

8.2 Maintenance



Crash and falling caused by unintentional activation

There is a risk of injury if the drive system is activated unintentionally.

- ▶ Remove the battery before maintenance.
-

The following maintenance measures must be carried out regularly [▷ *Check list, page 83*]. They can be carried out by the user and rider. In case of any doubt, consult the HERCULES specialist dealer.

8.2.1 Wheel

NOTICE

If the pressure is too low in the tyre, the tyre does not achieve its load bearing capacity. The tyre is not stable and may come off the rim.

If the pressure in the tyre is too high, the tyre may burst.

- ▶ Check the tyre pressure against the specifications [▷ *Data sheet, page 1*].
 - ▶ *Adjust the tyre pressure as necessary.*
-
- ▶ Check the *tyre* wear.
 - ▶ Check the *rim* wear.
 - The rims of a rim brake with invisible wear indicator are worn as soon as the wear indicator becomes visible in the area of the rim joint.
 - The rims with visible wear indicator are worn as soon as the black, all-round groove on the pad friction surface becomes invisible. We recommend that you also replace the *rims* with every second brake lining replacement.
 - ▶ Check the tension of the spokes.

8.2.2 Brake system

- ▶ Replace the brake linings on the disk brake when the pad thickness has reached 0.5 mm.

8.2.3 Electrical cables and brake cables

- ▶ Check all visible electrical cables and cables for damage. If, for example, the sheathing is compressed, the bicycle will need to be removed from service until the cables have been replaced.
- ▶ Check all electrical cables and cables to make sure they are fully functional.

8.2.4 Gear shift

- ▶ Check the gear shift and the *shifter* or the *twist grip* setting and adjust it as necessary.

8.2.5 USB port

NOTICE

Any moisture which enters through the USB port may trigger a short circuit in the *display*.

- ▶ Regularly check the position of the *cover on the USB port* and adjust it as necessary.

8.2.6 Chain or belt tension

NOTICE

Excessive chain or belt tension increases wear.

If the chain or belt tension is too low, there is a risk that the *chain* or belt will slip off the *chain wheels*.

- ▶ Check the chain and belt tension once a month.

Maintenance



- ▶ Check the chain or belt tension in three or four positions, turning the crank a full revolution.
 - ▶ If the *chain* or the belt can be pushed more than 2 cm, the *chain* or belt will need to be tensioned again by the HERCULES specialist dealer.
 - ▶ If the *chain* or the belt can only be pushed less than 1 cm, the *chain* or belt will need to be relieved of tension accordingly.
- ⇒ The ideal chain or belt tension has been achieved if the *chain* or the belt can be pushed a maximum of 2 cm in the middle between the pinion and the toothed wheel. The crank must also turn without resistance.

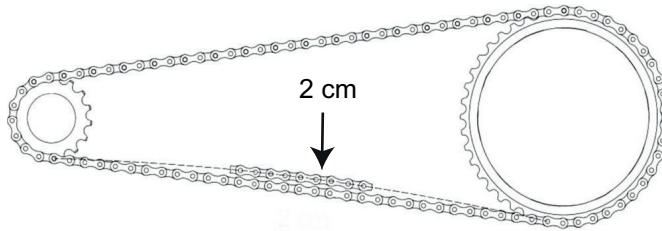

Figure 31:

Checking the chain and belt tension

8.3 Service



Crash and falling caused by unintentional activation

There is a risk of injury if the drive system is activated unintentionally.

- ▶ Remove the battery before the service.



Crash caused by material fatigue

If the service life of a component has expired, the component may suddenly fail. This may result in a crash and injuries.

- ▶ Have the HERCULES specialist dealer carry out six-monthly basic cleaning of the bicycle, preferably at the same time as the stipulated servicing work.

A service must be performed by the HERCULES specialist dealer at least every six months [▶ *Check list, page 83*]. This is the only way to ensure that the bicycle remains safe and fully functional.



- ▶ During basic cleaning, the HERCULES specialist dealer inspects the bicycle for any signs of material fatigue.
- ▶ The HERCULES specialist dealer checks the software version of the drive system and updates it. The electrical connections are checked, cleaned and preservative agent is applied. The electrical cables are inspected for damage.
- ▶ The further servicing measures correspond to those which are recommended for a bicycle as per EN 4210. Particular attention is paid to the rim and brake wear. The spokes are re-tightened in accordance with the findings.



Maintenance



8.4 Correcting and repairing

8.4.1 Using original parts only

The individual parts of the bicycle have been selected carefully and to matched to each other.

Only original parts must be used for maintenance and repair.

The constantly updated lists of approved accessories and parts are available to HERCULES specialist dealers.

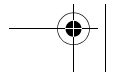
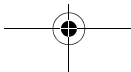
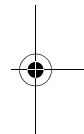
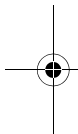

8.4.1 Wheel quick release



Crash caused by unfastened quick release

A faulty or incorrectly installed quick release may become caught in the brake disk and block the wheel. This will cause a crash.

- ▶ Install the front wheel quick release lever on the opposite side to the brake disk.



Crash caused by faulty or incorrectly installed quick release

The brake disk becomes very hot during operation. Parts of the quick release may become damaged as a result. The quick release comes loose. This will result in a crash and injuries.

- ▶ The front wheel quick release lever and the brake disk must be situated on opposite sides.



Crash caused by incorrectly set clamping force

Excessively high clamping force will damage the quick release and cause it to lose its function.

Insufficient clamping force will cause a detrimental transmission of force. The suspension fork or the frame may break. This will result in a crash and injuries.

- ▶ Never fasten a quick release using a tool (e.g. hammer or pliers).
- ▶ Only use the clamping lever with the specified set clamping force.

Maintenance

8.4.1.1

Clamping the clamping lever

The clamping lever for the quick release is marked OPEN and CLOSE. If you can read the word OPEN, the quick release is open. If you can read the word CLOSE, the quick release is clamped.

- ▶ Align the clamping lever properly and push it through as far as it will go.
- ⇒ The wheel clamping lever is clamped if the clamping lever can be moved easily from the open final position into the middle and has to be pressed with the fingers or base of the thumb from the middle point onwards.

8.4.1.2

Clamping version I

- ▶ Hold the open clamping lever. Screw the setting nut tight on the opposite side.
- ▶ Clamp the clamping lever.
- ⇒ The final position of the clamping lever is at a right angle to the fork or frame.

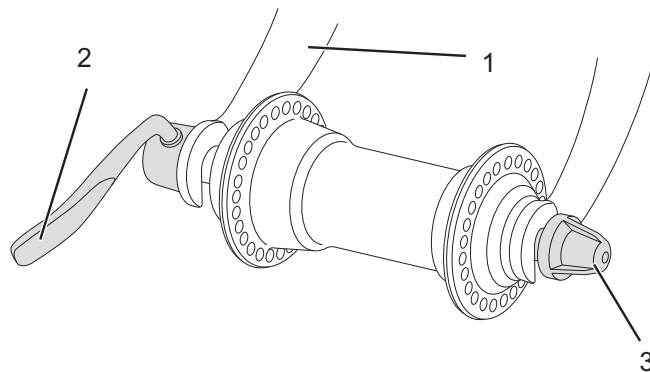

Figure 32: Wheel quick release, version I, with clamping lever (2), fork (1) and setting nut (3)

Checking and setting the clamping force of the quick releases

If the clamping lever cannot be moved into the final position just by pushing it with the hand, or if it is too loose, its clamping force will need to be readjusted.

- ✓ The clamping lever is completely open.
- ▶ Turn the setting nut a little.
- ▶ Clamp the clamping lever.
- ▶ Repeat the steps until the proper angle has been achieved.

8.4.1.3

Clamping version II

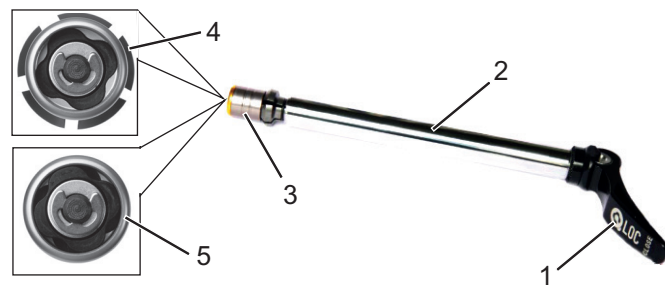

Figure 33:

Quick release, version II, with clamping lever (1), axle (2), setting nut (3), and detailed view of the open (4) and closed (5) flange

- ✓ The clamping lever is completely open.
- ▶ Push the axle into the hub as far as it will go.
- ▶ Align the clamping lever.
- ▶ Close the clamping lever
- ⇒ The final position of the clamping lever is forward, parallel to the fork.

Maintenance

8.4.1.4 Clamping version III

NOTICE

If the clamping force is insufficient, have the HERCULES specialist dealer inspect it.

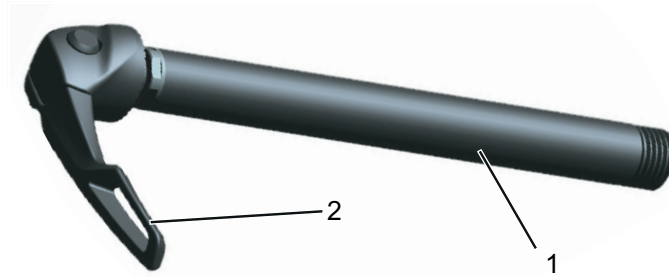

Figure 34: Quick release, version III, with axle (1) and clamping lever (2)

- ▶ Push the axle into the hub as far as it will go with the clamping lever completely open.
- ▶ Screw the quick release on the open clamping lever clockwise into the hub as far as it will go.
- ▶ Screw it out one turn.
- ▶ Use the fingers to screw in the clamping lever in the semi-open position, roughly in the middle between OPEN and CLOSE, until you feel resistance.
- ▶ Clamp the clamping lever.

8.4.1.5

Clamping version IV

- ▶ Push the axle into the hub as far as it will go with the clamping lever open.
- ▶ Screw the clamping lever clockwise into the correct final position.
- ▶ Clamp the clamping lever.

Setting the clamping force

If the clamping force is set too high, the clamping lever cannot be pushed into the closed final position.

- ▶ Turn the twist knob:
 - Turn 1/8 turn anti-clockwise to reduce the clamping force.
 - Turn 1/8 turn clockwise to increase the clamping force.
- ▶ Clamp the clamping lever.
- ▶ If the clamping lever is not yet in the proper final position, repeat the steps until the proper final position has been achieved.

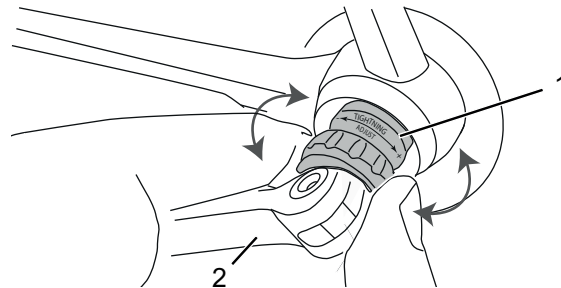

Figure 35:

Wheel quick release, version IV, with twist knob (1) and clamping lever (2)

Maintenance

8.4.1.6

Clamping version V



Crash caused by unfastened quick release

The clamping force of the quick release lever is set once during assembly and is not an indication that the wheel axle is sufficiently fastened. The axle may come loose if the closed quick release is turned. This will result in a crash and injuries.

► Never adjust or turn a quick release after closing it, e.g. in order to correct the final position.

► Push the axle into the hub from the left until it meshes in the thread on the right-hand fork end.



Figure 36:

Quick release, version V, with axle (1) and clamping lever (2)

► Flip the quick release lever into the recess.

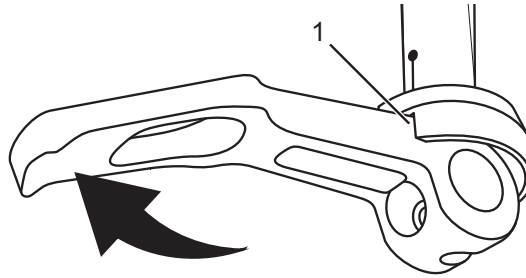

Figure 37: Flipping the quick release into the recess (1)

- ▶ Turn the axle on the quick release clockwise until the axle is firmly in place.
- ▶ Pull the lever from the recess and clamp it properly.
- ▶ The clamping force of the lever is not an indication of the tightening torque of the axle.

Setting the clamping force

If the clamping lever cannot be moved into its proper final position by pushing it with the hand, or if it is too loose, its clamping force will need to be readjusted.

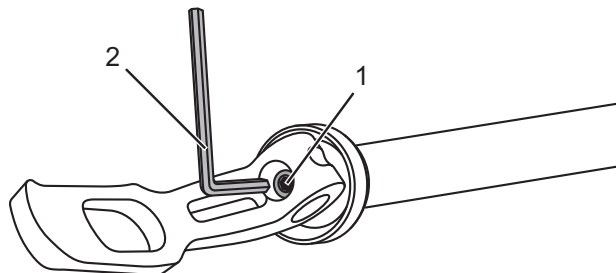

Figure 38: Setting the clamping force in the middle of the clamping lever (1) with a hexagon socket spanner (2)

Maintenance



- ▶ Open the quick release lever.
- ▶ Connect a 2.5 mm hexagon socket spanner to the middle of the clamping lever.
- ▶ Turn the hexagon socket spanner:
 - clockwise to increase the clamping force and
 - anti-clockwise to reduce the clamping force.
- ▶ Clamp the clamping lever.
- ▶ If the clamping lever is not yet in the proper final position, repeat the steps until the proper final position has been achieved.

8.4.2 Adjusting the tyre pressure

8.4.2.1 Dunlop valve

The tyre pressure cannot be measured on the simple Dunlop valve. The tyre pressure is therefore measured in the filling hose when pumping slowly with the bicycle pump.

- ✓ It is recommendable to use a bicycle pump with a pressure gauge. The operating instructions for the bicycle pump must be adhered to.
- ▶ Unscrew and remove the valve cap.
- ▶ Connect the bicycle pump.
- ▶ Pump up the tyre slowly and pay attention to the tyre pressure in the process.
- ⇒ The tyre pressure has been adjusted as per the data [[▷ Data sheet, page 1](#)].
- ▶ If the tyre pressure is too high, unfasten the union nut, let off air and tighten the union nut again.
- ▶ Remove the bicycle pump.
- ▶ Screw the valve cap tight.
- ✓ Screw the rim nut gently against the rim with the tips of your fingers.

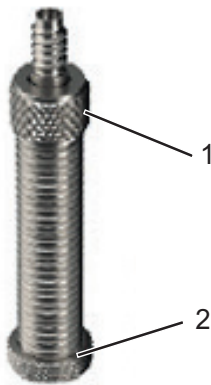

Figure 39: Dunlop valve with union nut (1) and rim nut (2)

Maintenance

8.4.2.2

Presta valve

- ✓ It is recommendable to use a bicycle pump with a pressure gauge. The operating instructions for the bicycle pump must be adhered to.
- ▶ Unscrew and remove the valve cap.
- ▶ Open the knurled nut around four turns.
- ▶ Carefully apply the bicycle pump so that the valve insert is not bent.
- ▶ Pump up the tyre slowly and pay attention to the tyre pressure in the process.
- ⇒ The tyre pressure has been adjusted as per the data [▷ *Data sheet, page 1*].
- ▶ Remove the bicycle pump.
- ▶ Tighten the knurled nut with your finger tips.
- ▶ Screw the valve cap tight.
- ▶ Screw the rim nut gently against the rim with the tips of your fingers.



Figure 40:

Presta valve with valve insert (1), knurled nut (2) and rim nut (3)

8.4.2.3

Schrader valve

- ✓ It is recommendable to use a bicycle pump with a pressure gauge. The operating instructions for the bicycle pump must be adhered to.
- ▶ Unscrew and remove the valve cap.
- ▶ Connect the bicycle pump.
- ▶ Pump up the tyre slowly and pay attention to the tyre pressure in the process.
- ⇒ The tyre pressure has been adjusted as per the data [[▷ Data sheet, page 1](#)].
- ▶ Remove the bicycle pump.
- ▶ Screw the valve cap tight.
- ▶ Screw the rim nut gently against the rim with the tips of your fingers.



Figure 41:

Schrader valve with rim nut (1)

Maintenance

8.4.3 Adjusting the gear shift

If the gears cannot be selected cleanly, the setting for the shift cable tension will need to be adjusted.

- ▶ Carefully pull the *adjusting sleeve* away from the shifter housing, turning it in the process.
- ▶ Check the function of the gear shift after each adjustment.



If the gear shift cannot be set this way, the assembly of the gear shift will need to be inspected by the HERCULES specialist dealer.

8.4.3.1

Cable-operated gear shift, single-cable (Alternative version)

- ▶ For a smooth gear shift, adjust the adjusting sleeves on the gear shift housing.

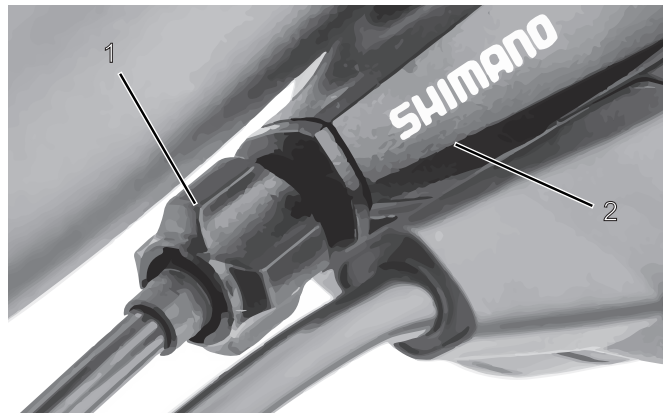

Figure 42:

Adjusting sleeve (1) for the single-cable cable-operated gear shift with gear shift housing (2), example

8.4.3.2 Cable-operated gear shift, dual-cable (Alternative version)

- ▶ For a smooth gear shift, set the adjusting sleeves underneath the chain stay on the frame.
- ▶ The shift cable has play of approximately 1 mm when it is pulled out gently.

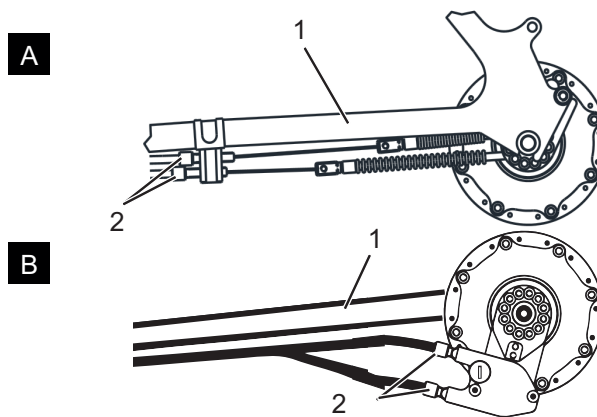

Figure 43: Adjusting sleeves (2) on two alternative versions (A and B) of a dual-cable cable-operated gear shift on the chain stay (1)

Maintenance

8.4.3.3 Cable-operated twist grip, dual-cable (Alternative version)

- ▶ For a smooth gear shift, set the adjusting sleeves on the gear shift housing.
- ⇒ There is noticeable play of around 2 - 5 mm (1/2 gear) when twisting the twist grip.

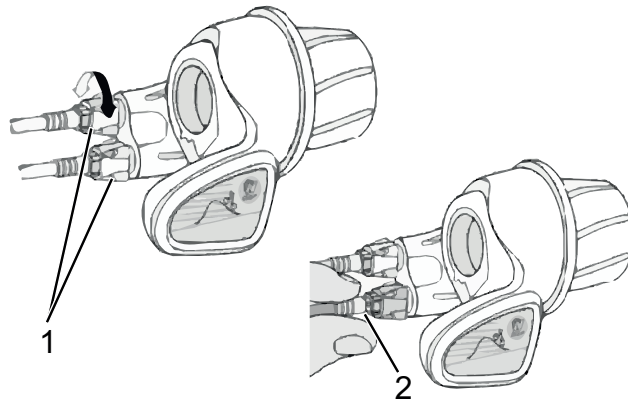

Figure 44: Twist grip with adjusting sleeves (1) and play of the gear shift (2)

8.4.4 Replacing the lighting

Alternatively a 3 watt or 1.5 watt lighting system can be installed.

- ▶ Only use components of the respective power class for replacement.

8.4.5 Setting the lamp

- ▶ The *lamp* must be set so that its light beam meets the road 10 m in front of the bicycle.

8.4.6 Repair by the specialist dealer



Special knowledge and tools are required for many repairs. Only a HERCULES specialist dealer must carry out the following repairs, for instance:

- Replacing *tyres* and rims,
- Replacing the brake pads and brake linings,
- Replacing and tensioning the *chain*.

Maintenance

8.4.7

First aid for system messages



Fire and explosion due to faulty batteries

The safety electronics on damaged or faulty batteries may fail. The residual voltage can cause a short circuit. The batteries may self-ignite and explode.

- ▶ Batteries with external damage must be removed from service immediately.
 - ▶ Never allow damaged batteries to come into contact with water.
 - ▶ If a battery is dropped or struck but shows no signs of external damage, remove the battery from service and observe it for at least 24 hours.
 - ▶ Faulty batteries are hazardous goods. Dispose of faulty batteries properly and as quickly as possible.
 - ▶ Store in a dry place until disposal. Never store in the vicinity of flammable substances.
 - ▶ Never open or repair the battery.
-

The components of the drive system are checked constantly and automatically. If an error is detected, the respective error code appears on the *display*. The drive may be shut off automatically, depending on the type of error.

8.4.7.1

First aid

If an error message is displayed, run through the following actions:

- ▶ Make a note of the system message.
- ▶ Shut off and re-start the drive system.
- ▶ If the system message is still displayed, remove and then re-insert the battery.
- ▶ Re-start the drive system.
- ▶ If the system message is still displayed, contact the HERCULES specialist dealer.

8.4.7.2**Specific error eradication**

- ▶ Make a note of the system message.

Error	Remedy
10	▶ Charge the battery.
12	▶ Charge the battery.
24	Incorrect charger. ▶ Use the supplied charger for charging.
40, 41, 44	Overcurrent detected and motor overheating ▶ Relieve the motor with reduced pedalling or a lower assistance level.

Table 29:**Error eradication using the code**

- ▶ If the system message is still displayed, contact the HERCULES specialist dealer.

Maintenance

8.4.8

The electric drive system or display do not start up

If the display and/or the drive system do not start up, proceed as follows:

- ▶ Check whether the battery is switched on. If not, start the battery.
- ⇒ If the LEDs of the charge status indicator do not light up, contact the HERCULES specialist dealer.
- ▶ If the LEDs of the charge status indicator light up, but the drive system does not start up, remove the battery.
- ▶ Insert the battery.
- ▶ Start the drive system.
- ▶ If the drive system does not start up, remove the battery.
- ▶ Clean all the contacts with a soft cloth.
- ▶ Insert the battery.
- ▶ Start the drive system.
- ▶ If the drive system does not start up, remove the battery.
- ▶ Fully charge the battery.
- ▶ Insert the battery.
- ▶ Start the drive system.
- ▶ If the drive system does not start up, remove the display.
- ▶ Fasten the display.
- ▶ Start the drive system.
- ▶ If the drive system does not start up, contact the HERCULES specialist dealer.

8.5 Accessories

<i>Description</i>	<i>Article number</i>
Protective cover for electrical components	080-41000 ff
Panniers system components*	080-40946
Rear wheel basket system components*	051-20603
Bicycle box system components*	080-40947

Table 30:

Accessories

*System components are matched to the pannier rack and provide sufficient stability due to special transmission of force.

Maintenance

8.5.1 Child seat



Crash caused by improper handling

When using child seats, the riding properties and the stability of the bicycle change considerably. This can cause a loss of control, a crash and injuries.

- ▶ You should practice how to use the child seat safely and reliably before using the bicycle in public spaces.



Risk of crushing due to exposed springs

The child may crush his/her fingers on exposed springs or open mechanical parts of the saddle or the seat post.

- ▶ Never install saddles with exposed springs if a child seat is being used.
- ▶ Never install seat posts with suspension with open mechanical parts or exposed springs if a child seat is being used.



NOTICE

- ▶ Observe the legal regulations on the use of child seats.
 - ▶ Observe the operating and safety notes for the child seat system.
 - ▶ Never exceed the total weight of the bicycle.
-



The HERCULES specialist dealer will advise you on the choice of right child seat system for the child and the bicycle. The scope of delivery of commercially available child seats does not usually contain any of the material which is required to adapt the bicycle to the child seat.

Moreover, knowledge, skills and tools which a technical layperson does not have, may be required.

Therefore, the initial installation of a child seat must be performed by the HERCULES specialist dealer in order to maintain operational and product safety. When installing a child seat, the HERCULES specialist dealer makes sure that the seat and the fastening mechanism for the seat suit the bicycle, that all components are installed and firmly fastened, that shift cables, brake cables, hydraulic and electrical cables are adjusted as necessary, that the freedom of movement of the rider is not restricted, and the permitted total weight of the bicycle is not exceeded.

The HERCULES specialist dealer provides instruction on how to handle the bicycle and the child seat.

Maintenance

8.5.2 Bicycle trailer



CAUTION

Crash caused by brake failure

The brake may not work sufficiently if there is an excessive trailer load. The long braking distance can cause a crash or an accident and injuries.

▶ Never exceed the specified trailer load.



NOTICE

▶ The operating and safety notes for the trailer system must be observed.

▶ The legal regulations on use of bicycle trailers must be observed.

▶ Only use type approved coupling systems.

A bicycle which is approved for towing a trailer is equipped with the respective information sign. Only bicycle trailers with a support load and total mass which do not exceed the permitted values, must be used.



The HERCULES specialist dealer will advise you on the choice of right trailer system for the bicycle. The scope of delivery of commercially available bicycle trailers does not usually contain any of the material which is required to adapt the bicycle to the trailer. Moreover, knowledge, skills and tools which a technical layperson does not have, may be required.

Therefore, the initial installation of a trailer must be performed by the HERCULES specialist dealer in order to maintain operational and product safety.

9 Recycling and disposal



Risk of fire and explosion

The safety electronics on damaged or faulty batteries may fail. The residual voltage can cause a short circuit. The batteries may self-ignite and explode.

- ▶ Remove batteries with external damage from service immediately and never charge them.
- ▶ If the battery becomes deformed or begins to smoke, keep at a safe distance, disconnect the power supply at the socket, and notify the fire service immediately.
- ▶ Never extinguish damaged batteries with water or allow them to come into contact with water.
- ▶ Faulty batteries are hazardous goods. Dispose of faulty batteries properly and as quickly as possible.
- ▶ Store in a dry place until disposal. Never store in the vicinity of flammable substances.
- ▶ Never open or repair the battery.



Chemical burns to the skin and eyes

Liquids and vapours may leak from damaged or faulty batteries. They can irritate the airways and cause burns.

- ▶ Avoid contact with leaked liquids.
- ▶ Immediately consult a doctor in case of contact with the eyes or any discomfort.
- ▶ In case of contact with the skin, rinse off immediately with water.
- ▶ Ventilate the room well.

Maintenance

The bicycle, the battery, the display and the charger are recyclable materials. They have to be disposed of separate from the domestic waste in accordance with the valid legal regulations, and recycled.

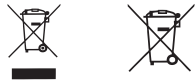

Separate collection and recycling saves reserves of raw materials and ensures that all the regulations for protection of health and the environment are adhered to when recycling the product and/or the battery.

- ▶ Never dismantle the bicycle, the battery or the charger for disposal.
- ▶ The bicycle, the display, the unopened and undamaged battery and the charger can be returned to any HERCULES specialist dealer free of charge. Depending on the region, further disposal options may be available.
- ▶ Store the individual parts of the decommissioned bicycle in a dry place, free from frost, where they are protected from direct sunlight.

10 EC declaration of conformity

Translation of the original EC declaration of conformity

The manufacturer:

HERCULES GMBH
Longericher Str. 2
50739 Köln

hereby declares that the electrically power assisted cycles of types:

18-R-0001, 18-R-0002, 18-R-0003, 18-R-0005

year of manufacture 2017 and year of manufacture 2018,

comply with all applicable requirements of **Machinery Directive 2006/42/EC**. Furthermore, the electrically power assisted cycles comply with all applicable basic requirements of **Radio Equipment Directive 2014/53/EU**.

The following standards were applied: **EN ISO 12100:2010** Safety of machinery – General principles of design – Risk assessment and reduction, **EN ISO 4210-2:2015**, Cycles – Safety requirements for bicycles – Part 2: Requirements for city and trekking, young adult, mountain and racing bicycles, **EN 15194:2009+A1:2011**, Cycles – Electrically power assisted cycles – EPAC bicycles, **EN 11243:2016**, Cycles – Luggage carriers for bicycles – Requirements and test methods.

Mr. Harald Guoth Dipl.-Ing. (FH) (Quality Management Officer, Compliance Officer),
c/o HERCULES GMBH, Longericher Str. 2, 50739 Köln

is authorised to compile the technical documentation.



Cologne, 06.09.2017

.....
Place, date and signature

Georg Honkomp
-Managing Director-

List of tables

11 List of tables

Table 1:	Bicycle technical data, 2
Table 2:	Battery technical data, 2
Table 3:	Technical data for battery of the command console with display, 3
Table 4:	Emissions from the bicycle*, 3
Table 5:	USB port technical data, 3
Table 6:	Tightening torque values*, 3
Table 7:	Identification number of the operating instructions, 11
Table 8:	Type number, model and bicycle type categorisation, 11
Table 9:	Meanings of the signal words, 13
Table 10:	Safety markings on the product, 14
Table 11:	Area of use, 15
Table 12:	Bicycle type, 15
Table 13:	Information on the type plate, 16
Table 14:	Simplified terms, 17
Table 15:	Conventions, 17
Table 16:	Battery technical data, 32
Table 17:	Technical data for the command console with display, 33
Table 18:	Overview of the command console with display, 34
Table 19:	USB port technical data, 35
Table 20:	Overview of the screen display, 35
Table 21:	Display of levels of assistance, 36
Table 22:	Journey information, 36
Table 23:	System functions, 37
Table 24:	Storage temperature for the battery, the bicycle and the charger, 40
Table 25:	Working environment temperature, 42
Table 26:	Axle nut tightening torque, 44
Table 27:	Handlebars clamping screw maximum tightening torque, 49
Table 28:	Setting the compression damper, 57
Table 29:	Error eradication using the code, 107
Table 30:	Accessories, 109

12 Table of figures

- Figure 1: Type plate, example, 18
- Figure 2: Bicycle, viewed from the right, example of SNOS FS PRO, 23
- Figure 3: Detailed view of bicycle from rider position, example, 24
- Figure 4: Components of the wheel, example of front wheel, 25
- Figure 5: Bicycle without suspension (1) and with suspension (2) when riding over an obstacle, 26
- Figure 6: Arrangement of the suspension systems for the front wheel (I) and rear wheel (II), 27
- Figure 7: Bicycle brake system with a disk brake, example, 28
- Figure 8: Diagram of electric drive system, 29
- Figure 9: Diagram of electric drive system, 30
- Figure 10: Integrated battery details, 32
- Figure 11: Details of the command console with display, 34
- Figure 12: Overview of the displays, 35
- Figure 13: Detailed view of the seat post, examples of the minimum insertion depth marking, 47
- Figure 14: Determining the saddle height, 48
- Figure 15: Seat post quick release in the final position, 48
- Figure 16: Closed clamping lever (2) with knurled nut (3) and locking lever (1) on the stem, 50
- Figure 17: Suspension fork setting wheel, example, 52
- Figure 18: Fork valve, example, 53
- Figure 19: Setting the hardness on the suspension damping element, 54
- Figure 20: Setting the rebound damper, example with hare and tortoise symbol, 55
- Figure 21: Setting the hardness on the suspension damping element, 56
- Figure 22: Compression damper with locking lever (1), example, 57
- Figure 23: Brake lever (1) with knurled screw (2), 58
- Figure 24: Fork lock on the suspension for head with locking lever (1), example, 79
- Figure 25: Fork lock on handlebars, version I, with locking slider (1), 80
- Figure 26: Fork lock on handlebars, version II, with locking lever (1) and unlocking lever (2) (example), 80
- Figure 27: Fork lock on handlebars, version III, with long lever (1) and short lever (2), example, 81

Table of figures

- Figure 28: Fork lock on handlebars, version IV, with locking lever (1) and unlocking knob (2), 81
- Figure 29: Fork lock on handlebars, version V, with locking lever (1) and unlocking lever (2), 82
- Figure 30: Compression damper with locking lever (1), example, 82
- Figure 31: Checking the chain and belt tension, 88
- Figure 32: Wheel quick release, version I, with clamping lever (2), fork (1) and setting nut (3), 92
- Figure 33: Quick release, version II, with clamping lever (1), axle (2), setting nut (3), and detailed view of the open (4) and closed (5) flange, 93
- Figure 34: Quick release, version III, with axle (1) and clamping lever (2), 94
- Figure 35: Wheel quick release, version IV, with twist knob (1) and clamping lever (2), 95
- Figure 36: Quick release, version V, with axle (1) and clamping lever (2), 96
- Figure 37: Flipping the quick release into the recess (1), 97
- Figure 38: Setting the clamping force in the middle of the clamping lever (1) with a hexagon socket spanner (2), 97
- Figure 39: Dunlop valve with union nut (1) and rim nut (2), 99
- Figure 40: Presta valve with valve insert (1), knurled nut (2) and rim nut (3), 100
- Figure 41: Schrader valve with rim nut (1), 101
- Figure 42: Adjusting sleeve (1) for the single-cable cable-operated gear shift with gear shift housing (2), example, 102
- Figure 43: Adjusting sleeves (2) on two alternative versions (A and B) of a dual-cable cable-operated gear shift on the chain stay (1), 103
- Figure 44: Twist grip with adjusting sleeves (1) and play of the gear shift (2), 104

13 Index

A

Alternative equipment, 17
Alternative version, 17

B

Basic cleaning, 85
Battery, 32
- charging, 67
- checking, 45
- cleaning, 84
- disposing of, 114
- eradicating charging errors, 106
- waking, 69
Belt tension, 87
Brake caliper, 28
Brake disk, 28
Brake lever, 24
Brake linings, 28
Brake pad,
- maintaining, 87
Break in operation, 40
- carrying out, 41
- preparing, 41

C

Chain drive, 29
Chain guard,
- checking, 62
Chain tension, 87
Chain wheel, 29
Chain, 23, 29
- cleaning, 85
- maintaining, 88
- replacing, 105
Charge status indicator, 33
Charger,
- disposing of, 114
Clamping force,
- Checking the quick releases, 93
- Setting the quick releases, 93
Clamping lever,
Seat post, 48, 54
Compression damper,
- locking, 82

D

Damper, 26
Compression damper, 26
Rebound damper, 26
Damping, 26
Dashpot, see Compression damper
Dashpot, see Rebound damper
Data sheet, 1
Direction of travel, 29
Display,
- cleaning, 84
Drive system, 29
- switching off, 71
- switching on, 70

E

EC declaration of conformity, 115
Error message, see System message

F

Fork lock, 24
Fork, 25
Fork end, 25
Frame number, 1
Frame, 23
Front wheel brake 28
Front wheel brake,
- braking, 78
Front wheel, see Wheel

G

Gear shift twist grip,
- checking, 87
Gear shift,
- maintaining, 87
- switching, 76

H

Handlebars, 23, 24
- cleaning, 85
- installing, 44
- setting, 49
Hub, 25

I

Initial commissioning, 43

J

Journey information, 36, 37
- resetting, 74
- switching, 74

K

Knurled nut, 48

L

Lamp, 30
Level of assistance, 36
- selecting, 73
Lighting, see Running light

M

Mass, see Weight
Minimum insertion depth marking, 47
Model year, 18
Model, 1
Motor, 30
Mudguards,
- checking, 62

O

Operating status indicator, 33

P

Packaging, 42
Pannier rack,
- checking, 62
Parts list, 115
Pedal, 29
Pushing aid,
- using, 72

Q

Quick release, 25

R

Rear light, 30
Rear wheel brake 28
Rear wheel, see Wheel
Rim, 25
- checking, 86
- replacing, 105
Running light, 33
- checking function, 62
- replacing, 105

Index

S

- Saddle, 23
 - changing the saddle tilt, 49
 - changing the seat length, 49
 - clamping, 48
 - determining the saddle height, 47
 - installing, 44
- Screen display, 35
- Seat post, 23
 - clamping, 51
 - cleaning, 85
- Shifter, 24
 - checking, 87
 - setting, 89, 101, 102
- Spoke, 25
- Storage, 40
- Storing, see Storage
- Suspension fork, 26
 - locking, 79
- Suspension head, 25
- Suspension system, 26
- Suspension, 26
- System message, 37
 - understanding, 106

T

- Transportation, 38
- Transporting, see Transportation
- Type number, 1, 18
- Tyre pressure, 1
- Tyre size, 1
- Tyres, 25
 - checking, 86
 - replacing, 105

U

- USB port,
 - using, 74

V

- Valve, 25
 - Dunlop valve, 25
 - Presta valve, 25
 - Schrader valve, 25

W

- Weight,
 - Maximum weight, 18
 - Unladen weight, 1
- Wheel circumference, 1
- Wheel,
 - maintaining, 86
- Winter break, see Break in operation
- Working environment, 42

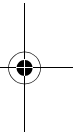
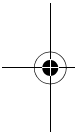
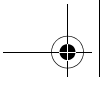

Text and images:
HERCULES GMBH
Longericher Straße 2
50739 Köln, Germany

Translation:
Tanner Translations GmbH+Co
Markenstraße 7
40227 Düsseldorf, Germany

Operating instructions: 034-11521_1.0_23.10.2017

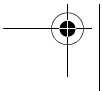
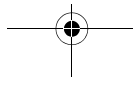

www.hercules-bikes.de

HERCULES GMBH
Longericher Straße 2
50739 Köln, Germany

Tel.: +49 4471 18735-0
Fax: +49 4471 18735-29
E-mail: info@hercules-bikes.de

YOUR HERCULES SPECIALIST DEALER

