



HERCULES

IMPORTANT
READ CAREFULLY BEFORE USE
KEEP SAFE FOR LATER REFERENCE

TRANSLATION OF THE ORIGINAL OPERATING INSTRUCTIONS

EN

ELECTRIC BICYCLES

E-Imperial 180, Montfoort, Viverly-E, Robert/a, Futura,
E-Joy, Cargo 1000, Rob Fold

19-P-0001, 19-P-0002, 19-P-0003, 19-P-0004, 19-P-0005, 19-P-0006, 19-P-0007, 19-Q-0003, 19-Q-0004,
19-Q-0006, 19-Q-0007, 19-Q-0008, 19-Q-0010, 19-Q-0011, 19-Q-0012, 19-Q-0019, 19-Q-0020, 19-Q-0021,
19-Q-0022, 19-Q-0024, 19-Q-0025, 19-Q-0026, 19-Q-0027, 19-Q-0030, 19-Q-0031, 19-Q-0032, 19-Q-0033,
19-Q-0034, 19-Q-0035, 19-Q-0036, 19-Q-0037, 19-Q-0038, 19-Q-0040, 19-Q-0041, 19-Q-0042, 19-Q-0043,
19-Q-0044, 19-Q-0046, 18-Q-0047, 19-Q-0053, 19-Q-0054, 19-Q-0055, 19-Q-0056, 19-Q-0057, 19-Q-0058,
19-Q-0059, 19-Q-0060, 19-Q-0061, 19-Q-0062, 19-Q-0063, 19-Q-0064, 19-Q-0065, 19-Q-0066, 19-Q-0067,
19-Q-0068, 19-Q-0069, 19-Q-0070, 19-Q-0071, 19-Q-0080, 19-Q-0081, 19-Q-0098, 19-Q-0099, 19-Q-0100,
19-Q-0101, 19-Q-0102, 19-Q-0103, 19-X-0082, 19-Y-0003, 19-Y-0004, 19-Y-0005, 19-Y-0006, 19-Y-0007,
19-Y-0008, 19-Y-0009

Copyright

© HERCULES GMBH

Distribution or reproduction of these operating instructions and utilisation or communication of their content is prohibited unless expressly approved. Any infringement will render the offender liable for compensation. All rights reserved in the event that a patent, utility model or industrial design is registered.

Data sheet

Surname, first name of the purchaser:

Date of purchase:

Model:

Frame number:

Type number:

Unladen weight (kg):

Tyre size:

Recommended tyre pressure (bar)*: front: rear:

Wheel circumference (mm):

Company stamp and signature:

*After a tyre change, refer to the tyre markings for the permitted tyre pressures and make sure that they are observed. The recommended tyre pressure must not be exceeded.

Table of contents

1	About these instructions	8
1.1	Manufacturer	8
1.2	Laws, standards and directives	9
1.3	Other valid documents	9
1.4	Subject to change	10
1.5	Language	10
1.6	Identifying	11
1.6.1	Operating instructions	11
1.6.2	Bicycle	11
1.7	For your safety	15
1.7.1	Instruction, training and customer service	15
1.7.2	Basic safety notes	16
1.7.3	Warnings	16
1.7.4	Safety markings	17
1.8	For your information	17
1.8.1	Instructions for actions	17
1.8.2	Information on the type plate	17
1.8.3	Language conventions	20
1.9	Type plate	21
2	Safety	22
2.1	Requirements for the rider	22
2.2	Hazards for vulnerable groups	22
2.3	Personal protective equipment	22
2.4	Proper use	23
2.4.1	City and trekking bicycle	23
2.4.2	Folding bicycle	24
2.4.3	Carrier bicycle	24
2.5	Improper use	25
2.5.1	City and trekking bicycle	25
2.5.2	Folding bicycle	26
2.5.3	Carrier bicycle	26
2.6	Duty to take care	26
2.6.1	Rider	26
2.6.2	Operator	26
3	Description	28
3.1	Overview	28
3.2	Handlebars	29
3.3	Wheel and suspension	30
3.3.1	Valve	30
3.3.2	Suspension	31

3.3.3	Suspension fork structure	32
3.4	Brake system	33
3.4.1	Rim brake	33
3.4.2	Disk brake	35
3.4.3	Back-pedal brake	36
3.5	Electric drive system	37
3.5.1	Battery	39
3.5.1.1	Charge status indicator	42
3.5.2	Driving light	43
3.5.3	Display	43
3.5.3.1	Display operating elements	44
3.5.3.2	USB port	45
3.5.3.3	Displays	45
3.5.4	Control panel	52
4	Technical data	53
5	Transportation, storage and assembly	56
5.1	Transportation	56
5.1.1	Using the transport securing system	58
5.2	Storing	58
5.2.1	Break in operation	59
5.2.1.1	Preparing a break in operation	60
5.2.1.2	Taking out of operation	60
5.3	Assembly	61
5.3.1	Required tools	61
5.3.2	Unpacking	62
5.3.3	Scope of delivery	62
5.3.4	Commissioning	63
5.3.4.1	Checking the battery	65
5.3.5	Mounting the wheel	66
5.3.5.1	Mounting the wheel with screw-on axle (15 mm)	66
5.3.5.2	Mounting the wheel with screw-on axle (20 mm)	68
5.3.5.3	Mounting the wheel with a quick release axle	69
5.3.6	Mounting the wheel with a quick release	73
5.3.6.1	Check stem and handlebars	76
5.3.7	Sale of the bicycle	78
6	Before the first ride	79
6.1	Adjusting the saddle	79
6.1.1	Adjusting the saddle tilt	79

Table of contents

6.1.2	Determining the seat height	80
6.1.3	Adjusting the seat height with quick release	81
6.1.4	Setting the height-adjustable seat post	82
6.1.4.1	Lowering the saddle	83
6.1.4.2	Raising the saddle	83
6.1.5	Adjusting the seat position	84
6.2	Setting the handlebars	85
6.2.1	Adjusting the handlebar height	86
6.2.2	Turning the handlebars to the side	87
6.2.2.1	Checking the clamping force of the quick releases	88
6.2.2.2	Adjusting the quick release clamping force	88
6.3	Adjusting the brake lever	88
6.3.1	Adjusting the pressure point on a Magura brake lever	88
6.3.2	Adjusting the grip distance	89
6.3.2.1	Adjusting the grip distance on a Magura brake lever	90
6.4	Adjusting the suspension	91
6.4.1	Adjusting the negative deflection	92
6.4.1.1	Adjusting the steel suspension fork negative deflection	92
6.4.1.2	Adjusting the air suspension fork negative deflection	93
6.5	Retracting brake linings	94
7	Operation	95
7.1	Before each ride	97
7.2	Check list before each ride	98
7.3	Using the kickstand	99
7.4	Using the pannier rack	100
7.5	Battery	102
7.5.1	Down tube battery	104
7.5.1.1	Removing the down tube battery	104
7.5.1.2	Inserting the down tube battery	105
7.5.2	Pannier rack battery	106
7.5.2.1	Removing the pannier rack battery	106
7.5.2.2	Inserting the pannier rack battery	106
7.5.3	Integrated battery	107
7.5.3.1	Removing the integrated battery	107
7.5.3.2	Inserting the integrated battery	108
7.5.4	Charging the battery	109
7.5.5	Charging the dual battery	111
7.5.5.1	Charging process when two batteries are used	113
7.5.5.2	Charging process when one rechargeable battery is used	113

7.5.6	Waking the battery	113
7.6	Electric drive system	114
7.6.1	Switching on the drive system	114
7.6.2	Switching off the drive system	115
7.6.3	Switching on the drive system from the control panel with display	116
7.6.4	Switching off the drive system	117
7.7	Screen	118
7.7.1	Removing and attaching the display	118
7.7.2	Securing display against removal	119
7.7.3	Charging the internal display battery	120
7.7.4	Using the USB port	121
7.7.5	Switching on the display	121
7.7.6	Switch off screen	121
7.7.7	Using the push assist	122
7.7.8	Using the driving light	123
7.7.9	Selecting the level of assistance	123
7.7.10	Journey information	123
7.7.10.1	Changing the displayed journey information	123
7.7.10.2	Resetting the journey information	123
7.7.11	Changing the system settings	124
7.8	Gear shift	126
7.8.1	Selecting gears	126
7.8.2	Using derailleur gears	127
7.8.3	Using a hub gear	128
7.9	Brake	130
7.9.1	Using the brake lever	134
7.9.2	Using the back-pedal brake	134
7.10	Folding	135
7.10.1	Folding the folding bicycle	135
7.10.1.1	Folding the pedal	135
7.10.2	Folding the stem, version I	136
7.10.2.1	Folding the stem, version II	137
7.10.2.2	Pushing in the seat post	137
7.10.2.3	Folding the frame	138
7.10.3	Preparing the bicycle so that it is ready to ride again	139
7.10.3.1	Folding out the frame	139
7.10.3.2	Folding out the pedal	140

8	Maintenance	141
8.1	Cleaning and servicing	143
8.1.1	After every ride	143
8.1.1.1	Clean suspension fork	143
8.1.1.2	Cleaning the pedals	143
8.1.2	Basic cleaning	144
8.1.2.1	Cleaning the frame	144
8.1.2.2	Cleaning the stem	145
8.1.2.3	Clean rear frame damper	145
8.1.2.4	Cleaning the wheel	145
8.1.2.5	Cleaning the drive elements	145
8.1.2.6	Cleaning the chain	146
8.1.2.7	Cleaning the battery	146
8.1.2.8	Cleaning the drive unit	147
8.1.2.9	Cleaning the display	147
8.1.2.10	Cleaning the brake	148
8.1.3	Servicing	149
8.1.3.1	Servicing the frame	149
8.1.3.2	Servicing the stem	149
8.1.3.3	Servicing the fork	149
8.1.3.4	Servicing the drive elements	149
8.1.3.5	Servicing the pedal	149
8.1.3.6	Servicing the chain	150
8.1.3.7	Servicing the drive elements	150
8.2	Maintenance	151
8.2.1	Wheel	151
8.2.2	Brake system	152
8.2.3	Electrical cables and brake cables	152
8.2.4	Gear shift	152
8.2.5	Stem	153
8.2.6	Checking the chain and belt tension	153
8.2.7	USB port	154
8.2.8	Suspension fork	154
8.3	Service	155
8.4	Adjusting and repairing	157
8.4.1	Use original parts and lubricants only	157
8.4.2	Axle with quick release	158
8.4.2.1	Checking the quick release	159
8.4.3	Adjusting the tyre pressure	160
8.4.3.1	Dunlop valve	160
8.4.3.2	Presta valve	161

8.4.3.3	Schrader valve	162
8.4.4	Adjusting the gear shift	163
8.4.4.1	Cable-operated gear shift, single-cable	163
8.4.4.2	Cable-operated gear shift, dual-cable	164
8.4.4.3	Cable-operated twist grip, dual-cable	165
8.4.5	Offsetting brake lining wear	166
8.4.5.1	Hydraulically operated rim brake	166
8.4.5.2	Hydraulically operated disc brake	167
8.4.6	Replacing the lighting	167
8.4.7	Setting the headlight	167
8.4.8	Repair by the specialist dealer	167
8.5	Cargo 1000 accessories	168
8.5.1	Child seat	168
8.5.2	Bicycle trailer	170
8.5.3	Pannier rack	171
8.5.4	First aid	172
8.5.5	The electric drive system or display do not start up	173
8.5.5.1	System messages	174
8.5.5.2	Special system messages	174
9	Recycling and disposal	176
10	Appendix	178
10.1	System messages	178
10.2	EC declaration of conformity	183
10.3	Parts list	184
10.4	Table of figures	218
10.5	List of tables	221
10.6	Index	223

1

About these instructions

Read these operating instructions before commissioning the bicycle to ensure you use all the functions correctly and safely. The operating instructions are not a substitute for personal instruction by the supplying specialist dealer. The operating instructions are a component part of the bicycle. Therefore, if it is re-sold at a later time, they must be handed over to the subsequent owner.

These operating instructions are mainly directed at the rider and operator of the cycle. In general, they are technical laypersons.



Text passages which are expressly intended for specialist staff (e.g. bicycle mechanics) are clearly marked with a tool symbol.

Staff at all specialist dealers have specialist training and qualifications, and are therefore capable of identifying risks and preventing hazards which may arise during maintenance, servicing and repairs on the bicycle. Information for specialist staff does not require non-professionals to take any action.

1.1

Manufacturer

The manufacturer of the bicycle is:

HERCULES GmbH
Longericher Straße 2
50739 Köln, Germany

Tel.: +49 4471 18735 0
Fax: +49 4471 18735 29
E-mail: info@hercules-bikes.de
Internet: www.hercules-bikes.de

1.2

Laws, standards and directives

These operating instructions comply with the essential requirements from:

- the Machinery Directive 2006/42/EC,
- Electromagnetic Compatibility Directive 2014/30/EU,
- EN ISO 12100:2010 Safety of machinery – General principles of design – Risk assessment and reduction,
- EN 15194:2015, Cycles – Electrically power assisted cycles – EPAC bicycles,
- ISO 4210, Cycles – Safety requirements for bicycles
- EN 11243:2016, Cycles – Luggage carriers for bicycles – Requirements and test methods,
- EN 82079-1:2012, Preparation of instructions for use – Structuring, content and presentation – Part 1: General principles and detailed requirements,
- EN ISO 17100:2016-05, Translation Services – Requirements for translation service.

1.3

Other valid documents

These operating instructions are only complete in conjunction with the other valid documents.

The following document applies for this product:

- Charger operating instructions.

No other information is also applicable.

The constantly updated lists of approved accessories and parts are available to specialist dealers.

1.4 Subject to change

The information contained in these operating instructions are the approved technical specifications at the time of printing. Any significant changes are included in a new issue of the operating instructions.

You will find any modifications to these operating instructions at:

www.hercules-bikes.de/de/de/index/downloads

1.5 Language

The original operating instructions are written in German. A translation is not valid without the original operating instructions.

1.6 Identifying

1.6.1 Operating instructions

The identification number of these operating instructions is made up of the document number, the version number and the release date. It can be found on the cover page and in the footer.

Identification number	034-11572_1.0_29.08.2018
------------------------------	--------------------------

Table 1: Identification number of the operating instructions

1.6.2 Bicycle

These HERCULES operating instructions refer to the *model year* 2019. The production period is from July 2018 to June 2019. The instructions were issued in July 2018.

The operating instructions are a component part of the following bicycles:

<i>Type number</i>	<i>Model</i>	<i>Bicycle type</i>
19-P-0001	E-Imperial 180 S F8	Carrier bicycle
19-P-0002	E-Imperial 180 S F8	Carrier bicycle
19-P-0003	E-Imperial 180 S R8	Carrier bicycle
19-P-0004	E-Imperial 180 S R8	Carrier bicycle
19-P-0005	E-Imperial 180 S 9	Carrier bicycle
19-P-0006	E-Imperial 180 S 9	Carrier bicycle
19-P-0007	E-Imperial 180 S 9	Carrier bicycle
19-Q-0003	Montfoort F7	City and trekking bicycle
19-Q-0004	Montfoort F7	City and trekking bicycle
19-Q-0006	Montfoort plus F8	City and trekking bicycle

Table 2: Type number, model and bicycle type categorisation

Type number	Model	Bicycle type
19-Q-0007	Viverty-E F7	City and trekking bicycle
19-Q-0008	Viverty-E R7	City and trekking bicycle
19-Q-0010	Robert/a F7 Active Plus	City and trekking bicycle
19-Q-0011	Robert/a F7 Active Plus	City and trekking bicycle
19-Q-0012	Futura Compact 8	Folding bicycle
19-Q-0019	Futura Compact R8	Folding bicycle
19-Q-0020	Futura Compact R8	Folding bicycle
19-Q-0021	Futura Compact F8	Folding bicycle
19-Q-0022	Futura Compact F8	Folding bicycle
19-Q-0024	Robert/a R7 Active Plus	City and trekking bicycle
19-Q-0025	Robert/a R7 Active Plus	City and trekking bicycle
19-Q-0026	Robert/a deLuxe I F8	City and trekking bicycle
19-Q-0027	Robert/a deLuxe I F8	City and trekking bicycle
19-Q-0030	Robert/a deLuxe I R8	City and trekking bicycle
19-Q-0031	Robert/a deLuxe I R8	City and trekking bicycle
19-Q-0032	Robert/a PRO I F8	City and trekking bicycle
19-Q-0033	Robert/a PRO I F8	City and trekking bicycle
19-Q-0034	Robert/a PRO I R8	City and trekking bicycle
19-Q-0035	Robert/a PRO I R8	City and trekking bicycle
19-Q-0036	Robert/a PRO F8	City and trekking bicycle
19-Q-0037	Robert/a PRO F8	City and trekking bicycle
19-Q-0038	Robert/a PRO F8	City and trekking bicycle

Table 2: Type number, model and bicycle type categorisation

<i>Type number</i>	<i>Model</i>	<i>Bicycle type</i>
19-Q-0040	Robert/a PRO R8	City and trekking bicycle
19-Q-0041	Robert/a PRO R8	City and trekking bicycle
19-Q-0042	Robert/a F8	City and trekking bicycle
19-Q-0043	Robert/a F8	City and trekking bicycle
19-Q-0044	Robert/a F8	City and trekking bicycle
19-Q-0046	Robert/a R8	City and trekking bicycle
18-Q-0047	Robert/a R8	City and trekking bicycle
19-Q-0053	Futura PRO I XT 11sp	City and trekking bicycle
19-Q-0054	Futura PRO I XT 11sp	City and trekking bicycle
19-Q-0055	Futura PRO I F14	City and trekking bicycle
19-Q-0056	Futura PRO I F14	City and trekking bicycle
19-Q-0057	Futura PRO I F14	City and trekking bicycle
19-Q-0058	Futura PRO I-F360	City and trekking bicycle
19-Q-0059	Futura PRO I-F360	City and trekking bicycle
19-Q-0060	Futura PRO I-F360	City and trekking bicycle
19-Q-0061	Futura COMP I LX 10sp	City and trekking bicycle
19-Q-0062	Futura COMP I LX 10sp	City and trekking bicycle
19-Q-0063	Futura COMP I LX 10sp	City and trekking bicycle
19-Q-0064	Futura Sport I 8.1	City and trekking bicycle
19-Q-0065	Futura Sport I 8.1	City and trekking bicycle
19-Q-0066	Futura Sport I 8.1	City and trekking bicycle

Table 2:**Type number, model and bicycle type categorisation**

Type number	Model	Bicycle type
19-Q-0067	Futura Sport I Deore 9sp	City and trekking bicycle
19-Q-0068	Futura Sport I Deore 9sp	City and trekking bicycle
19-Q-0069	Futura Sport I Deore 9sp	City and trekking bicycle
19-Q-0070	Futura Sport I-F8	City and trekking bicycle
19-Q-0071	Futura Sport I-F8	City and trekking bicycle
19-Q-0080	E-Joy F7	City and trekking bicycle
19-Q-0081	E-Joy R7	City and trekking bicycle
19-Q-0098	Futura PRO I-F11	City and trekking bicycle
19-Q-0099	Futura PRO I-F11	City and trekking bicycle
19-Q-0100	Futura PRO I-F11	City and trekking bicycle
19-Q-0101	Futura Sport I-F8	City and trekking bicycle
19-Q-0102	Futura Sport I-F8	City and trekking bicycle
19-Q-0103	Futura Sport I-F8	City and trekking bicycle
19-X-0082	Cargo 1000	Carrier bicycle
19-Y-0003	Rob Fold R8	Folding bicycle
19-Y-0004	Rob Fold F8	Folding bicycle
19-Y-0005	Rob Fold 9	Folding bicycle
19-Y-0006	Rob Fold 8 Carbon	Folding bicycle
19-Y-0007	Rob Fold I-F8	Folding bicycle
19-Y-0008	Rob Fold I-R8	Folding bicycle
19-Y-0009	Rob Fold Pro I-F8	Folding bicycle

Table 2: Type number, model and bicycle type categorisation

1.7

For your safety

The safety concept of the bicycle comprises four elements:

- rider and/or operator instruction, and bicycle maintenance and repair by the specialist dealer,
- the chapter on general safety,
- the warnings in these instructions and
- the safety marking on the type plates.

1.7.1

Instruction, training and customer service

The supplying specialist dealer will provide customer service. Contact details can be found on the back page of these operating instructions and in the data sheet. If you are unable to contact your specialist dealer, you will find other specialist dealers to attend to your customer service needs on www.hercules-bikes.de.



The specialist dealer authorised to perform repairs and maintenance work receives regular training.

The rider or the operator of the bicycle will be instructed in person on the bicycle functions when the supplying specialist dealer hands over the bicycle, if not before. This instruction particularly covers the bicycle's electrical functions and correct use of the charger.

Each rider to whom this bicycle is provided must receive instruction on the bicycle's functions. The operating instructions must be submitted to each rider in printed form and must be acknowledged and adhered to.

1.7.2 **Basic safety notes**

These operating instructions have a chapter with general safety notes [▷ *Chapter 2, page 22*]. The chapter stands out because of its grey background.

1.7.3 **Warnings**

Hazardous situations and actions are marked with warnings. The warnings in these operating instructions are shown as follows:





SIGNAL WORD	Type and source of the danger
	Description of the danger and the consequences.
	▶ Measures
	The following pictograms and signal words are used in the operating instructions for warnings and information notices:
	Will lead to serious or even fatal injuries if ignored. High-risk hazard.
	May lead to serious or even fatal injuries if ignored. Medium-risk hazard.
	May lead to minor or moderate injuries. Low-risk hazard.
	May lead to material damage if ignored.

Table 3: **Meanings of the signal words**

1.7.4**Safety markings**

The following safety markings are used on the bicycle's type plates:



General warning



Adhere to the instructions for use

Table 4:

Meaning of safety markings

1.8**For your information****1.8.1****Instructions for actions**

Instructions for actions are structured in accordance with the following pattern:

- ✓ Requirements (optional)
- ▶ Instruction for action
- ⇒ Result of the action (optional)

1.8.2**Information on the type plate**

Alongside the warnings, the type plates of the products also contain other important information on the bicycle:



1

Suitable for tarmacked and paved roads – no off-road riding or jumps



2

Suitable for tarmacked roads, cycle paths and firm gravel paths and roads, longer sections with moderate slopes and jumps up to 15 cm.



3

Suitable for tarmacked roads, cycle paths and easy to demanding off-road riding, sections with moderate slopes and jumps up to 61 cm.



4

Suitable for tarmacked roads, cycle paths and easy to demanding off-road riding, limited downhill use up to 25 km and jumps up to 122 cm.



5

Suitable for tarmacked roads, cycle paths and easy to extremely difficult off-road riding, unlimited downhill use and any jumps

Table 5:

Relevance of area of use



City and trekking bicycle



Child's bicycle / bicycle for young adults



Mountain bike



Racing bicycle



Carrier bicycle



Folding bicycle

Table 6:

Relevance of bicycle type



Read the instructions



Separate collection of electrical and electronic devices



Separate collection of batteries



Must not be thrown into fire (burning prohibited)



Battery must not be opened



Device of protection class II



Only suitable for use indoors



Fuse (device fuse)



EU conformity



Recyclable material



Protect from temperatures above 50 °C and direct sunlight

Table 7:

Relevance of safety instructions

1.8.3

Language conventions

The bicycle described in these operating instructions may be equipped with alternative components. The equipment of the bicycle is defined by the respective type number. Where applicable, the word *alternative* beneath the heading indicates alternatively used components. The following terms are used for better legibility:

Term	Meaning
Operating instructions	Original operating instructions or translation of the original operating instructions
Bicycle	Electric motor driven cycle
Motor	Drive motor

The following conventions are used in these operating instructions:

Convention	Use
<i>Italics</i>	Entry in the index
SPACED	Displays on the <i>display screen</i>
[▷ <i>Example, page numbering</i>]	Cross references
•	Bulleted lists

1.9

Type plate

The type plate is situated on the *frame*. The type plate features the following information:

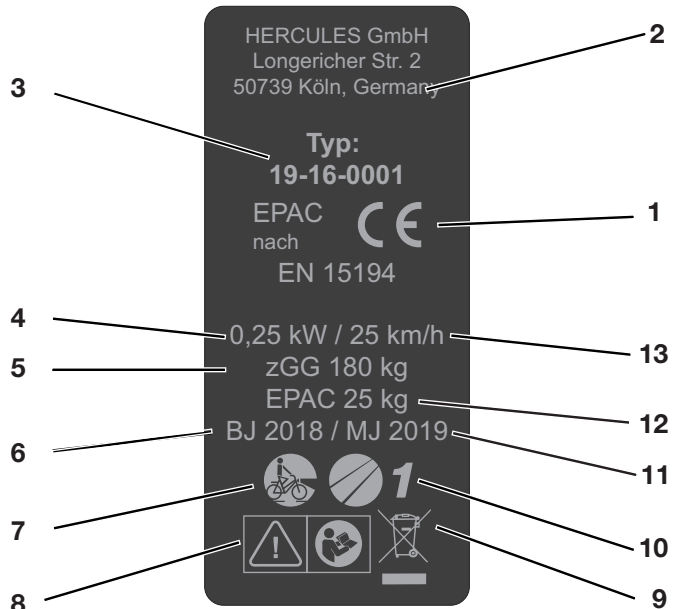

Figure 1:

Type plate, example

- 1 CE marking
- 2 Manufacturer
- 3 Type number
- 4 Nominal continuous power
- 5 Permitted total weight
- 6 Year of manufacture
- 7 *Bicycle type*
- 8 *Safety instructions*
- 9 *Disposal instruction*
- 10 *Area of use*
- 11 Model year
- 12 Weight of the ready-to-ride bicycle
- 13 Shut-off speed

2 Safety

2.1 Requirements for the rider

If there are no legal requirements for riders of electrically power-assisted cycles, we recommend that the rider should be a minimum 14 years of age and have experience with muscle-powered bicycles.

The rider's physical and mental abilities must be adequate to use a muscle-powered bicycle.

2.2 Hazards for vulnerable groups

The battery and the charger must be kept out of the reach of children.

If the bicycle is used by minors, comprehensive instruction should be provided by or in the presence of the legal guardians. Supervised use should also be scheduled until it is certain that the bicycle is being used as per these operating instructions. Legal guardians hold sole responsibility for determining whether minors are capable of using the bicycle.

2.3 Personal protective equipment

We recommend that you wear a suitable safety helmet. We also recommend that you wear typical, long, close-fitting cycling clothing and sturdy footwear.

2.4

Proper use

The bicycle is designed to support a maximum speed of 25 km/h. The bicycle may only be used in a perfect, fully functional condition.

National requirements may apply to the bicycle which differ from the standard equipment. For riding on public roads, some special regulations apply in relation to *driving light*, *reflectors* and other components.

The general laws and the regulations for the prevention of accidents and environmental protection in the respective country of use must be adhered to. All check lists and instructions for actions in these operating instructions must be met. Approved accessories can be installed by specialist staff.

Each bicycle is assigned a *bicycle type*, which determines its proper use and area of use.

2.4.1



City and trekking bicycle

City and trekking bicycles are designed for daily, comfortable use. They are suitable for riding on public roads.

Area of use:



1

Suitable for tarmacked and paved roads.



2

Suitable for tarmacked roads, cycle paths and firm gravel paths and roads, and longer sections with moderate slopes and jumps up to 15 cm.

2.4.2



Folding bicycle

The folding bicycle is suitable for use on public roads.

A folding bicycle can be folded up and is thus suitable for space-saving transportation, for example on public transport or in a car. The folding function of the folding bicycle makes it necessary to use smaller wheels and longer brake cables and Bowden cables. Therefore, in case of an increased load, a reduction in riding stability and braking power, diminished comfort and reduced durability are to be expected.

Area of use:

Suitable for tarmacked and paved roads.



2.4.3



Carrier bicycle

The carrier bicycle is suitable for daily transportation of loads on public roads. The transportation of loads requires skill and physical fitness in order to balance the additional weight. The very varied loading conditions and weight distributions require special practice and skill when braking and riding in bends. The length of the bicycle, the width and the turning circle require a longer period of adaptation. The carrier bicycle requires cautious riding. You must pay attention to the traffic on public roads and the condition of the route accordingly.

Area of use:

Suitable for tarmacked and paved roads.



2.5

Improper use

Failure to adhere to the proper use poses a risk of personal injury and material damage. The bicycle is not suitable for the following uses:

- when the electrical drive system has been manipulated
- when the permitted gross load weight is exceeded
- riding with a damaged or incomplete bicycle
- riding over steps
- riding through deep water
- lending the bicycle to untrained riders
- carrying other people
- riding with excessive or unsecured luggage
- riding with no hands
- riding on ice and snow
- improper servicing
- improper repair
- tough areas of use, such as professional competitions
- stunt riding or acrobatics.

2.5.1



City and trekking bicycle

City and trekking bicycles are not sports bicycles. If used for sports, the rider can expect reduced riding stability and diminished comfort.

Non-permitted areas of use:

**1**

Never drive off-road or perform jumps.

**2**

Never drive off-road or perform jumps over 15 cm.

2.5.2



Folding bicycle

The bicycle is not a sports bicycle.

Non-permitted areas of use:

Never drive off-road or perform jumps.

Only ride bicycle when locked in assembled position.

2.5.3



Carrier bicycle

A folding bicycle is not a touring bicycle or a sports bicycle.

Non-permitted areas of use:

Never drive off-road or perform jumps.

2.6

Duty to take care

The safety of the bicycle can only be assured if all the necessary measures are taken.

2.6.1

Rider

The rider:

- receives instruction before the first ride. can clarify any questions relating to the operating instructions with the operator or specialist dealer
- wears personal protective equipment.
- assumes all the obligations of the operator in case the bicycle changes hands.

2.6.2

Operator

The operator has the duty of care and responsibility for scheduling these measures and checking that they are implemented.

The operator:

- makes these operating instructions available to the rider for the duration of use of the bicycle. If necessary, they translate the operating instructions into a language which the rider understands.
- familiarises the rider with the functions of the bicycle before the first ride. Only riders who have received instruction may be allowed to ride.
- instructs the rider on proper use and the wearing of personal protective equipment.
- only employs specialist staff for maintenance and repair of the bicycle
- ensures that there is no unauthorised access, such as preventing replacement of gear sprockets with parts which are not original parts.

The printed EC Declaration of Conformity in the appendix is valid providing that the bicycle remains unchanged from its original condition. As soon as the operator makes any relevant modifications or additions, they legally become the manufacturer. He must independently guarantee compliance with the EC directives again in order to:

- circulate the bicycle again,
- attach the CE marking again and
- avoid compromising occupational safety.

3 Description

3.1 Overview

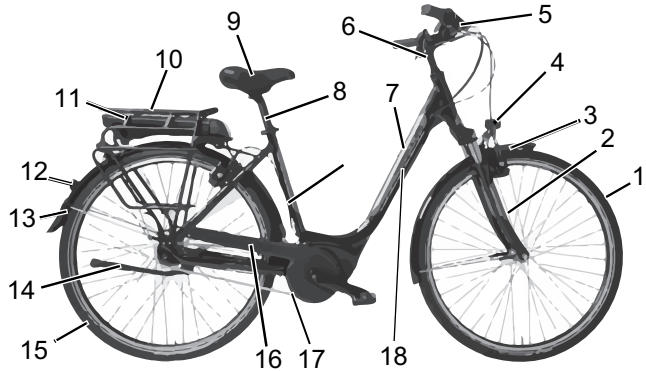

Figure 2: Bicycle, viewed from the right, example of City Cruiser

- 1 *Front wheel*
- 2 *Fork*
- 3 *Front mudguard*
- 4 *Headlight*
- 5 *Handlebars*
- 6 *Stem*
- 7 *Frame*
- 8 *Seat post*
- 9 *Saddle*
- 10 *Pannier rack*
- 11 *Pannier rack battery*
- 12 *Reflector and rear light*
- 13 *Rear mudguard*
- 14 *Kickstand*
- 15 *Rear wheel*
- 16 *Chain*
- 17 *Frame number*
- 18 *Chain guard*
- 19 *Type plate*

3.2

Handlebars

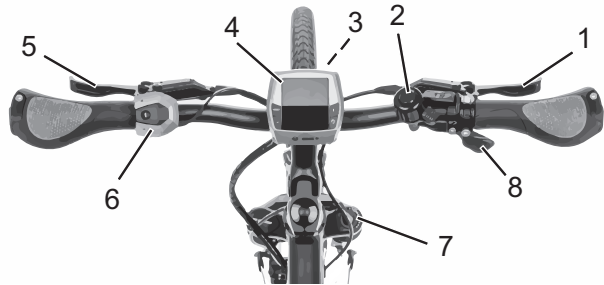

Figure 3: Detailed view of bicycle from rider position, example

- 1 Rear brake lever
- 2 Bell
- 3 Headlight
- 4 *Display*
- 5 Front brake lever
- 6 Control panel
- 7 Fork lock on *suspension fork head*
- 8 Shifter

3.3

Wheel and suspension

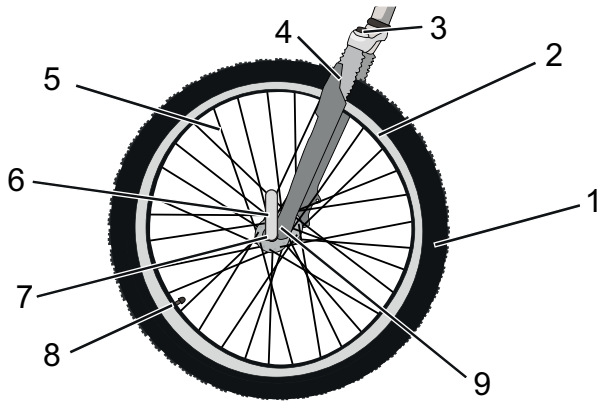

Figure 4:

Components of the wheel, example of front wheel

- 1 Tyre
- 2 Rim
- 3 Suspension fork head with setting wheel
- 4 Shock absorber
- 5 Spoke
- 6 Quick release
- 7 Hub
- 8 Valve
- 9 Fork end of the shock absorber

3.3.1

Valve

Each wheel has a valve. It is used to fill the *tyre* with air. There is a valve cap on each valve. The screw-on valve cap keeps out dust and dirt.

The bicycle either has a classical *Dunlop valve*, a *Presta valve* or a *Schrader valve*.

3.3.2

Suspension

Both forks and suspension forks are fitted in this model series. A suspension fork is based either on a steel spring or air suspension. Unlike a rigid fork, a suspension fork has two functions which improve floor contact and comfort: suspension and damping.

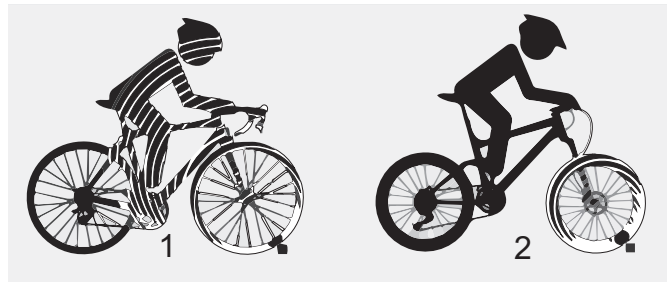

Figure 5: Bicycle without suspension (1) and with suspension (2) when riding over an obstacle

The suspension prevents an impact, such as one caused by a stone lying in the bike's path, from being channelled directly into the rider's body via the fork. The impact is absorbed by the suspension system instead. This causes the suspension fork to compress. The compression can be disabled so that a suspension fork reacts like a rigid fork. The switch to disable the fork is called a remote lockout.

After compressing, the suspension fork returns to its original position. If there is a damper, it decelerates movement, preventing the suspension system from springing back in an uncontrolled manner and stopping the fork from vibrating up and down.

Dampers which dampen compressive deflection movements, i.e. a compression load, are called compression dampers or compression dashpots.

Dampers which dampen rebound deflection movements, i.e. a rebound load, are called rebound dampers or dashpots.

3.3.3

Suspension fork structure

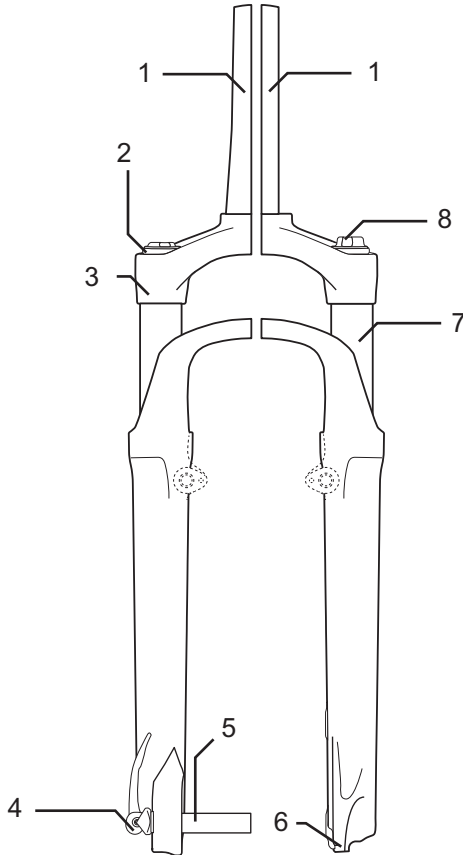

Figure 6:

Example: Suntour fork – The stem and handlebars are fastened to the fork shaft (1). The wheel is fastened to the quick release axle (5). Other elements: The compression setting (2) crown (3) Q-Loc (4) fork end for quick release (6) stanchion (7) suspension (8)

3.4 Brake system

The bicycle's brake system comprises either a hydraulic:

- rim brake on the front and rear wheels,
- disc brake on the front and rear wheels or
- a rim brake on the front and rear wheels and an additional back-pedal brake.

3.4.1 Rim brake *Alternative*

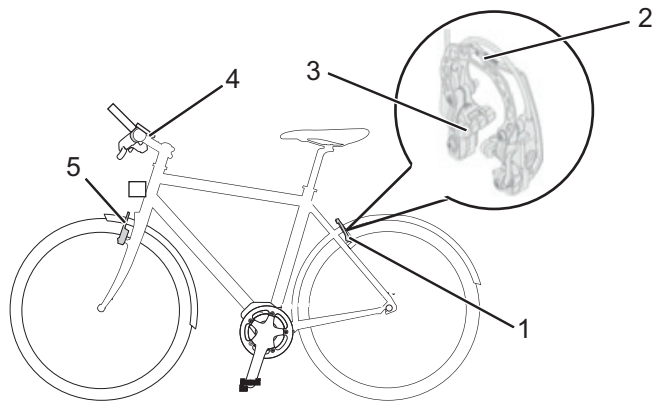

Figure 7: Rim brake components with details – example: Magura HS22

- 1 Rear wheel rim brake
- 2 Brake booster
- 3 Brake lining
- 4 *Handlebars with brake levers*
- 5 Front wheel rim brake

The rim brake stops the wheel moving when the rider pulls the *brake lever*, causing two brake linings, positioned opposite one another, to be pressed onto the *rims*.

The hydraulic rim brake features a locking lever

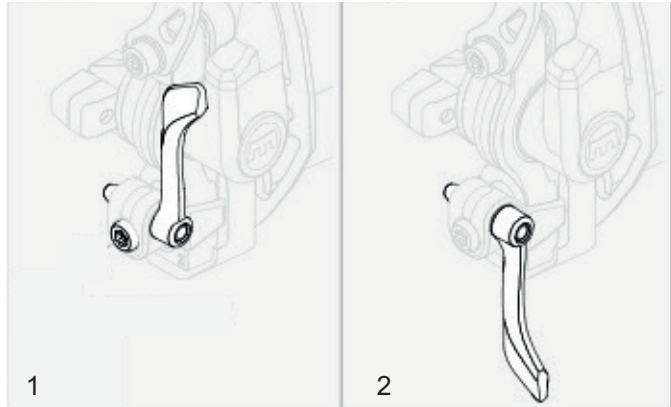

Figure 8: *Rim brake locking lever, closed (1) and open (2)*



The rim brake locking lever is not marked with any lettering. Only a specialist dealer may set the rim brake locking lever.

3.4.2

**Disk brake
Alternative**

Figure 9: Bicycle brake system with a disc brake, example

- 1 Brake disc
- 2 Brake caliper with brake linings
- 3 *Handlebars with brake levers*
- 4 Front wheel brake disc
- 5 Rear wheel brake disc

On a bicycle with a disc brake, the brake disc is screwed permanently to the *hub* of the wheel.

The brake lever is pulled to increase brake pressure. The brake fluid is used to transfer pressure through the brake lines to the cylinders in the brake caliper. The braking force is boosted by a speed reduction and applied to the brake linings. These apply the brake disc mechanically. If the brake lever is pulled, the brake linings are pressed against the brake disc, and the movement of the wheel is decelerated until it comes to a stop.

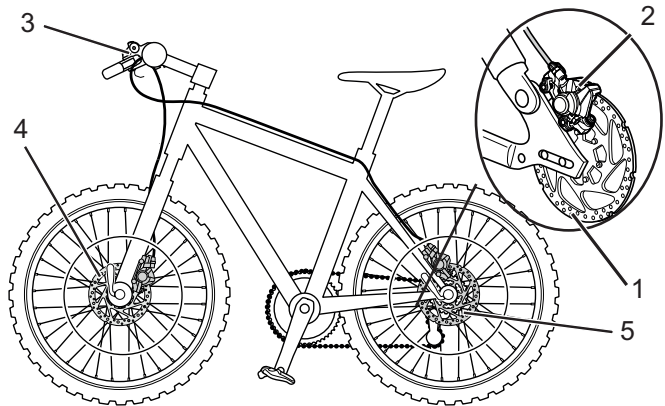
3.4.3

Back-pedal brake *Alternative*



Figure 10:

Brake system with a back-pedal brake, example

- 1 Rear wheel rim brake
- 2 *Handlebars with brake levers*
- 3 Front wheel rim brake
- 4 *Pedal*
- 5 Back-pedal brake

The back-pedal brake stops the movement of the rear wheel when the rider pedals in the opposite direction to the direction of travel.

3.5

Electric drive system

The bicycle is driven by muscle power via the chain drive. The force which is applied by pedalling in the direction of travel, drives the front chain wheel. The chain transmits the force onto the rear chain wheel and then onto the rear wheel.

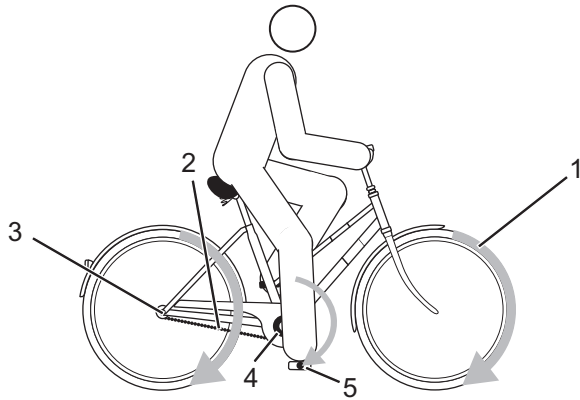

Figure 11:

Diagram of mechanical drive system

- 1 Direction of travel
- 2 Chain
- 3 Rear chain wheel
- 4 Front chain wheel
- 5 Pedal

The bicycle also has an integrated, electric drive system.

The electric drive system is made up of 8 components:

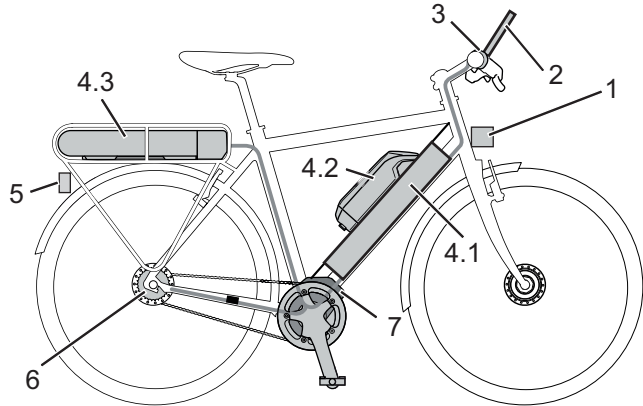

Figure 12:

Diagram of electric drive system

- 1 *Headlight*
- 2 *Display*
- 3 *Control panel*
- 4.1 *Integrated battery*
- 4.2 *Down tube battery and/or*
- 4.3 *Pannier rack battery*
- 5 *Rear light*
- 6 *Electric gear shift (alternative)*
- 7 *Motor*
- a charger which is designed for this battery.

As soon as the required muscle power from the rider pedalling passes a certain level, the motor is activated gently and assists the pedalling motion of the rider. The motor force is determined by the set level of assistance.

The bicycle does not have a separate emergency stop or emergency shut-off button. The drive system can be stopped in case of emergency by removing the *display*.

The motor switches off automatically as soon as the rider no longer pedals, the temperature is outside the permitted range, there is an overload or the shut-off speed of 25 km/h has been reached.

A push assist system can be activated. The speed depends on the selected gear. The push assist system continues to drive the bicycle at a slow speed as long as the rider presses the push assist button on the *handlebars*. The speed can be a maximum of 6 km/h in this case. The drive stops when the plus button is released.

3.5.1

Battery

The lithium ion battery has an internal electronic protection circuit. It is matched to the charger and the bicycle. The battery temperature is monitored at all times. The battery is safeguarded against deep discharge, overcharging, overheating and short circuit. In case of a risk the battery is switched off automatically by a protective circuit. If the electric drive system is not used for about 10 minutes (e.g. the bicycle is stationary) and no button has been pressed on the display or the control panel, the electric drive system and the battery are automatically switched off to save energy.

The service life of the battery can be extended if it is well cared for and, above all, stored at the correct temperatures. Even if the battery is cared for properly, the charge status of the battery reduces as it ages. If

the operating time is severely shortened after charging, this is a sign that the battery is spent.

Transportation temperature	5 °C–25 °C
Ideal transportation temperature	10 °C–15 °C
Storage temperature	5 °C–25 °C
Ideal storage temperature	10 °C–15 °C
Charging ambient temperature	10 °C–30 °C

Table 8: Battery technical data

The bicycle has either a down tube battery, a pannier rack battery or an integrated battery.

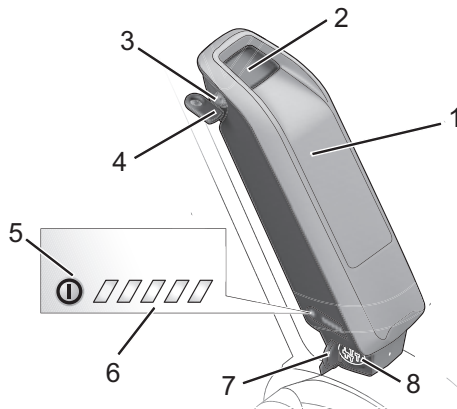

Figure 13: Details of the down tube battery

- 1 Battery housing
- 2 Battery lock
- 3 Key for the battery lock
- 4 On-Off button (battery)
- 5 Operating and charge status indicator
- 6 Charging port cover
- 7 Port for charger plug

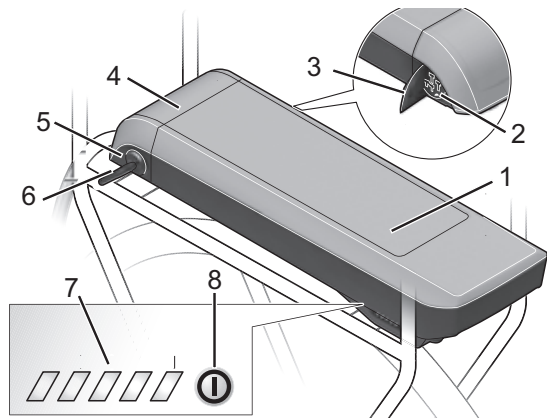

Figure 14:

Details of pannier rack battery

- 1 Battery housing
- 2 Charging port for charger plug
- 3 Charging port cover
- 4 Battery lock
- 5 Key for battery lock
- 6 *Operating and charge status indicator*
- 7 On-Off button (battery)

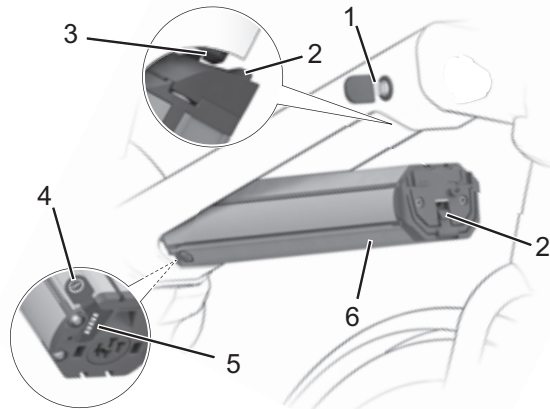

Figure 15:

Integrated battery details

- 1 Key for battery lock
- 2 Retainer guard
- 3 Securing hook
- 4 On-Off button (battery)
- 5 *Operating and charge status indicator*
- 6 Integrated battery housing

3.5.1.1

Charge status indicator

The five green LEDs on the charge status indicator show the battery charge status when the battery is switched on. Each LED represents about 20% of battery capacity. All five LEDs will light up when the battery is fully charged. The charge status of the activated battery is also shown on the *display*.

If the charge status of the battery is below 5%, all the LEDs on the charge status indicator will go out. However, the charge status is still shown on the *display*.

3.5.2 Driving light

When the driving light is activated, the *headlight* and the rear light are switched on together.

3.5.3 Display

The model series to which these instructions apply features a BOSCH Intuvia display. In addition to the functions described here, software changes may be introduced to rectify errors and extend functions at any time.

The display controls the drive system with four operating elements and shows the journey data. The rider can switch off the drive system by removing the display.

The bicycle's battery supplies the display with energy when the display is inserted in the mount, a sufficiently charged battery is inserted on the bicycle, and the drive system is switched on.

If the rider removes the display from the mount, the display draws its energy from the internal, rechargeable battery.

Internal lithium ion battery	3.7 V, 240 mAh
Storage temperature	5 °C–25 °C
Charging ambient temperature	10 °C–30 °C

Table 9: Technical data, display battery

3.5.3.1

Display operating elements

The *display* has four buttons and a USB port.

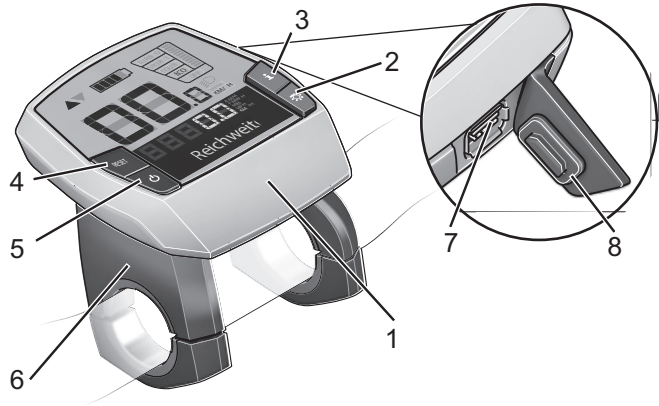

Figure 16:

Overview of the structure of the display's operating elements



Symbol	Use
1	Display housing
2 	Running light button
3 	Info button (display)
4 RESET	RESET button
5 	On-Off button (display)
6	Display mount
7	USB port
8	USB port protective flap

Table 10:

Operating element overview

3.5.3.2 USB port

There is a USB port underneath the rubber cover on the right-hand edge of the *display*.

Charge voltage	5 V
Charging current	max. 500 mA

Table 11: USB port technical data

3.5.3.3 Displays

The *display* has seven screen displays:

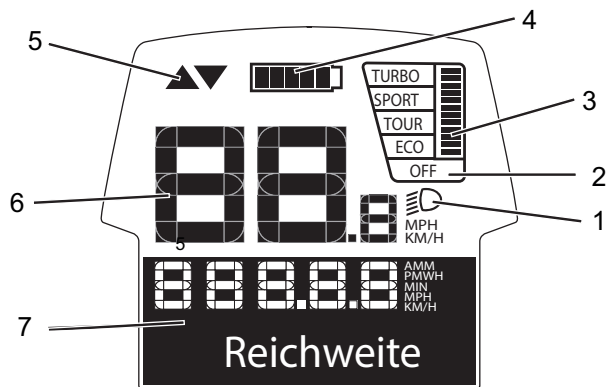

Figure 17: Overview of the displays

Use
1 Driving light symbol
2 Level of assistance
3 Motor power used
4 Charge status indicator
5 Gear recommendation
6 Tachometer screen
7 Function display

Table 12: Overview of the screen display

1. Driving light symbol

The driving light symbol is shown if the driving light is active.

2. Level of assistance

The higher the level for assistance, the more the drive system assists the rider when pedalling. The following levels of assistance are available

Different levels of assistance are available for different BOSCH motors.

Level of assistance	Use
OFF	When the drive system is switched on, the motor assistance is switched off. The bicycle can be used like a normal bicycle by simply pedalling. The push assist system cannot be activated.
ECO	Limited assistance with maximum efficiency for maximum range
TOUR	Constant assistance, for long-range tours
SPORT	Powerful assistance, for sport rides on mountainous rides and on urban roads.
TURBO	Maximum assistance up to high pedalling frequencies, for sport riding

Table 13:

Overview of levels of assistance, standard

eMTB mode is available for Performance Line CX drives. In eMTB mode, the assistance factor and the torque are dynamically adjusted depending on the pedalling force applied to the pedals. If the bicycle has been configured with eMTB mode, eMTB mode appears briefly when the SPORT level of assistance is selected.

Level of assistance	Use
OFF	When the drive system is switched on, the motor assistance is switched off. The bicycle can be used like a normal bicycle by simply pedalling. The push assist system cannot be activated.
ECO	Limited assistance with maximum efficiency for maximum range
TOUR	Constant assistance, for long-range tours
eMTB	Optimum assistance on all terrains, sport start-up, improved dynamics, maximum performance.
TURBO	Maximum assistance up to high pedalling frequencies, for sport riding

Table 14:



Overview of levels of assistance – eMTB mode**3. Motor power used**

The motor power used appears on the screen. The maximum motor power depends on the selected level for assistance.

4. Charge status indicator

The charge status indicator displays the bicycle battery charge level, not the display internal charge level. You can also see the battery charge status on the LEDs on the battery itself.

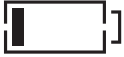
If the display is removed from its mount, the last displayed battery charge status message is saved.

Symbol	Meaning
	The battery is fully charged.
	The battery needs to be recharged.
	The LEDs on the battery charge level indicator have gone out. The capacity for drive assistance has been used up and assistance is gently switched off. The remaining capacity is reserved for lighting and the display. The screen flashes. The bicycle battery capacity is sufficient for about 2 hours more bicycle lighting. Other electrical loads, such as automatic gears and charging of external devices connected to the USB port, are not taken into account here.

Each bar in the rechargeable battery symbol on the screen represents about 20% capacity.

If a bicycle is used with two batteries, the battery charge status screen display shows the charge level for both batteries.

If both batteries are charged on a bicycle, the function display shows the charging progress for both batteries. You can see which of the two rechargeable batteries is currently being charged by the flashing screen display on the rechargeable battery.

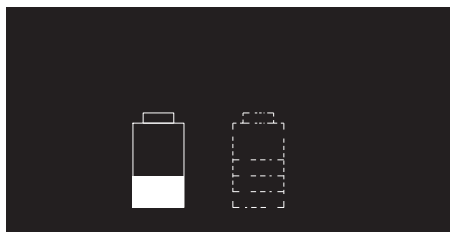

The left battery is currently being charged

5. Gear recommendation

You can increase the speed and range while applying the same force by selecting the right gear. It is therefore best to follow gear recommendations.

The gear recommendation function reacts to excessively slow or excessively quick pedalling and recommends a change of gear.

- ✓ The gear recommendation function has to be switched on in the system settings.

Symbol	Use
▲	Pedalling frequency is too high, a higher gear is recommended
▼	Pedalling frequency is too low, a lower gear is recommended

Table 15:

Symbols of the gear recommendation function

6. Tachometer screen

The tachometer shows the current speed at all times.

In the system settings, you can select whether the speed is displayed in kilometres or miles.

7. Function display

The function display shows texts and readings. Three different types of information are shown:

- Journey information,
- System settings and data, and
- System messages.

Journey information

Depending on the type of bicycle, the function display may show up to seven items of journey information. The displayed journey information can be switched.

screen display	Function
CLOCK	Current time
MAX SPEED	Maximum speed reached since the last RESET
AVG SPEED	Average speed reached since the last RESET
TRIP TIME	Journey time since last RESET
RANGE	anticipated range of the available battery charge
ODOMETER	Display of the total distance travelled (cannot be changed)
TRIP DISTANCE	Distance travelled since the last RESET

Table 16:

Journey information

System settings and data

In order to see the system settings and data, the rider has to call up the system settings. The rider can change the values of the system settings, but not the system data.

screen display	Function
- CLOCK +	Changing the time
- WHEEL CIRCUM +	Value of the wheel circumference in mm
- ENGLISH +	Changes the language
- UNIT KM/MI +	Selects whether the speed and distance are displayed in kilometres or miles
- TIME FORMAT +	Selects whether the time is displayed in 12-hour clock or 24-hour clock format
- SHIFT RECOM. OFF +	Switches the gear recommendation on and off

Table 17:

Changeable system settings

screen display	Function
POWER ON HOURS	Display of the total journey duration
DISPL. VX.X.X.X	Display software version
DU VX.X.X.X	Drive system software version
DU# XXXX XXXXX	Drive system serial number

Table 18:

System data, not changeable

screen display	Function
SERVICE MM/YYYY	(Alternative) defined inspection date
SERV. XX KM/MI	(Alternative) defined inspection
BAT. VX.X.X.X	Battery software version
1.BAT VX.X.X.X	Battery software version
2.BAT VX.X.X.X	Battery software version

Table 18:

System data, not changeable**System message**

The drive system monitors itself continuously and if an error is detected, it is indicated by a system message. The system may switch off automatically depending on the type of error. You will find assistance for system messages in *8.5 First aid*. There is a table of system messages in the Appendix.

3.5.4

Control panel

The control panel has four buttons.

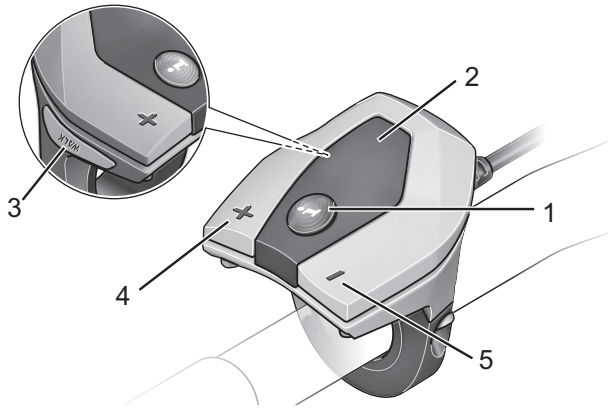

Figure 18:

Overview of the control panel

	Symbol	Surname
1		Info button (control panel)
2		Control panel
3	WALK	Push assist button
4	+	Plus button
5	-	Minus button

Table 19:

Overview of the control panel

4 Technical data

Bicycle

Transportation temperature	5 °C–25 °C
Ideal transportation temperature	10 °C–15 °C
Storage temperature	5 °C–25 °C
Ideal storage temperature	10 °C–15 °C
Operation temperature	5 °C–35 °C
Working environment temperature	15 °C–25 °C
Charging temperature	10 °C–30 °C
Power output/system	250 W (0.25 kW)
Shut-off speed	25 km/h
Weight of the ready-to-ride bicycle	See type plate

Table 20:

Bicycle technical data

Battery

Transportation temperature	5 °C–25 °C
Ideal transportation temperature	10 °C–15 °C
Storage temperature	5 °C–25 °C
Ideal storage temperature	10 °C–15 °C
Charging ambient temperature	10 °C–30 °C

Table 21:

Battery technical data

Display

Internal lithium ion battery	3.7 V, 230 mAh
Operating temperature	-5 °C–40 °C
Storage temperature	-10 °C–50 °C
Charging temperature	0 °C–40 °C
Protection rating (with USB cover closed)	IP54
Weight about	0.15 kg

Table 22: Display technical data

Emissions

A-weighted emission sound pressure level	< 70 dB(A)
Total vibration level for the hands and arms	< 2.5 m/s ²
Highest effective value of weighted acceleration for the entire body	< 0.5 m/s ²

Table 23: Emissions from the bicycle*

*The safety requirements as per Electromagnetic Compatibility Directive 2014/30/EU have been met. The bicycle and the charger can be used in residential areas without restriction.

USB port

Charge voltage	5 V
Charging current	max. 500 mA

Table 24: USB port technical data

Tightening torque

Axle nut tightening torque	35 Nm - 40 Nm
-----------------------------------	---------------

Handlebars clamping screw maximum tightening torque*	5 Nm - 7 Nm
---	-------------

Table 25:**Tightening torque values******if there is no other data on the component**

5 Transportation, storage and assembly

5.1 Transportation



Crash caused by unintentional activation

There is a risk of injury if the drive system is activated unintentionally.

- ▶ Remove the battery before the bicycle is transported.



Risk of fire and explosion due to high temperatures

Excessively high temperatures damage the batteries. The batteries may self-ignite and explode.

- ▶ Never expose the battery to sustained direct sunlight.



Oil leak if no transport securing device

The brake securing device prevents the brakes from being applied accidentally during transport. This could cause irreparable damage to the brake system or an oil leak, which will harm the environment.

- ▶ Never pull the brake lever when the wheel has been dismantled.
- ▶ Always use the transport securing system when transporting dismantled wheels.

NOTICE

If the bicycle is lying flat, oil and grease may leak from the bicycle.

If the shipping box with a bicycle is lying flat or on one end, it does not provide the *frame* and the wheels with adequate protection from damage.

- ▶ Only transport the bicycle in an upright position.
-

NOTICE

Bicycle rack systems which secure the bicycle standing on its head by the *handlebars* or *frame*, generate inadmissible forces on the components during transportation. This can cause the supporting parts to break.

▶ Never use bicycle rack systems which secure the bicycle standing on its head by the *handlebars* or *frame*.

▶ Take into account the ready-to-use bicycle's weight when transporting it.

▶ Remove the *display* and the battery before transportation of the bicycle.

▶ Protect the electrical components and connections on the bicycle from the elements with suitable protective covers.

▶ Remove accessories, for example drinking bottles, before transportation of the bicycle.

▶ When transporting by car, you must use a suitable bicycle rack system.



The specialist dealer will advise you on how to select a suitable rack system properly and how to use it safely.

▶ Transport the bicycle in a dry, clean place where it is protected from direct sunlight.



When shipping the bicycle, we recommend that you have the bicycle partially dismantled in the proper manner and packaged by the specialist dealer.

5.1.1

Using the transport securing system

- ▶ Insert the transport securing devices between the brake linings.
- ⇒ The transport securing device is squeezed between the two linings.

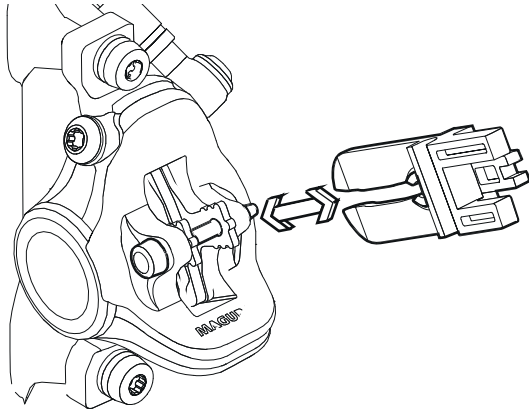

Figure 19:

Fastening the transport securing device

5.2

Storing



Risk of fire and explosion due to high temperatures

Excessively high temperatures damage the battery. The battery may self-ignite and explode.

- ▶ Protect battery against heat
- ▶ Never expose the battery to sustained direct sunlight.



If the bicycle is lying flat, oil and grease may leak from the bicycle.

If the shipping box with a bicycle is lying flat or on one end, it does not provide the *frame* and the wheels with adequate protection from damage.

- ▶ Only store the bicycle in an upright position.
-

- ✓ If the bicycle features a hydraulic seat post, fix only the lower seat post or the frame into a fitting stand to prevent damage to the upper seat post and the seat post lever.
- ✓ Never place a bicycle with a hydraulic seat post upside down on the floor; otherwise you, will damage the seat post lever.
- ✓ Store the bicycle, battery and charger in a dry and clean place.

Storage temperature	5 °C–25 °C
Ideal storage temperature	10 °C–15 °C

Table 26:

Storage temperature for the battery, the bicycle and the charger

5.2.1

Break in operation

NOTICE

The battery discharges when it is not used. This can cause damage to the battery.

- ▶ The battery has to be recharged every 8 weeks.

NOTICE

The battery may become damaged if it is connected permanently to the charger.

- ▶ Do not connect the battery to the charger permanently.

NOTICE

The internal battery in the display discharges when it is not used. This can cause it to be irreparably damaged.

- ▶ Charge the internal battery in the display every 3 months for at least 1 hour.

If the bicycle is to be removed from service for longer than four weeks, e.g. in winter, a break in operation has to be prepared.

5.2.1.1

Preparing a break in operation

- ✓ Remove the battery from the bicycle.
- ✓ Charge the battery to around 60% (three to four LEDs of the charge status indicator light up).
- ✓ The bicycle has to be cleaned with a damp cloth and preserved with wax spray. Never wax the friction surfaces of the brake.
- ✓ Before longer periods without use, it is recommendable to have your specialist dealer carry out servicing and basic cleaning and apply preservative agent.

5.2.1.2

Taking out of operation

- ▶ Store the bicycle, battery and charger in a dry and clean environment.
- ▶ Charge the internal battery in the display every 3 months for at least 1 hour.
- ▶ Check the charge status of the battery after 8 weeks. If only one LED of the charge status indicator lights up, recharge the battery to around 60%.

5.3

Assembly



Crushing caused by unintentional activation

There is a risk of injury if the drive system is activated unintentionally.

- ▶ Remove the battery if the battery is not absolutely necessary for assembly.



- ✓ Assemble the bicycle in a clean and dry environment.
- ✓ The working environment temperature should be between 15 °C and 25 °C.

Working environment temperature	15 °C–25 °C
--	-------------

Table 27:

Working environment temperature

- ✓ If a fitting stand is used, it must be approved for a maximum weight of 30 kg.
- ✓ To reduce the weight, we recommend that you always disconnect the battery from the bicycle for the duration of use of the fitting stand.

5.3.1

Required tools

The following tools are required to assemble the bicycle:

- Knife
- Hexagon socket spanner 2 (2.5 mm, 3, mm 4 mm, 5 mm, 6 mm and 8 mm)
- Torque wrench with working range between 5 and 40 Nm
- Twelve-point square socket T-25
- Ring spanner (8 mm, 9 mm, 10 mm, 13 mm, 14 mm and 15 mm) and
- Cross, flat head and ordinary screwdriver.

5.3.2

Unpacking



Hand injuries caused by cardboard packaging

The shipping carton is closed with metal staples. There is a risk of puncture wounds and cuts when unpacking and crushing the packaging.

- ▶ Wear suitable hand protection.
- ▶ Remove the metal staples with pliers before the shipping carton is opened.

The packaging material consists mainly of cardboard and plastic film.

- ▶ The packaging has to be disposed of in accordance with the regulations of the authorities.

5.3.3

Scope of delivery

The bicycle was completely assembled in the factory for test purposes and then dismantled for transportation.

The bicycle is 95–98% pre-assembled. The scope of delivery includes:

- the pre-assembled bicycle
- the front wheel
- the pedals
- quick release (optional)
- the charger
- the operating instructions.

The battery is supplied separately from the bicycle.

5.3.4

Commissioning**Fire and explosion caused by incorrect charger**

Batteries which are charged with an unsuitable charger, may become internally damaged. This may result in fire or an explosion.

- ▶ Only ever use the battery with the supplied charger.
- ▶ Mark the supplied charger and these operating instructions clearly to prevent mix-ups – with the bicycle *frame number* or *type number*, for example.

Since initial commissioning of the bicycle requires special tools and specialist knowledge, only trained specialist staff may perform initial commissioning.

Experience has shown that a bicycle which has not yet been sold, is spontaneously handed to consumers as soon as it appears ready to ride.

- ▶ For this reason, every bicycle must be prepared, so that it is fully ready for use immediately after being assembled.
- ▶ Staff should work through the initial commissioning check list to prepare the bicycle, so that it is ready to ride.

Initial commissioning check list

- | | |
|--------------------------|---|
| <input type="checkbox"/> | Check the battery |
| <input type="checkbox"/> | The battery is supplied partially charged. Fully charge the battery to ensure full power |
| <input type="checkbox"/> | Mount the wheels, quick release and pedals. |
| <input type="checkbox"/> | Re-adjust the quick release clamping force if necessary. |
| <input type="checkbox"/> | Thoroughly degrease the brake discs in disc brakes or the brake sides and linings in rim brakes with brake cleaner or spirit. |
| <input type="checkbox"/> | Place handlebars, stem and saddle in the functional position and check they are firmly in place. |
| <input type="checkbox"/> | Check all the components to make sure that they are firmly in place. Check all the settings and the tightening torque on the axle nuts. |
| <input type="checkbox"/> | Check the entire cable harness to make sure that it is routed properly: <ul style="list-style-type: none">• You must prevent the cable harness from coming into contact with moving parts.• The cable routes must be smooth and free from sharp edges.• Moving parts must not apply any pressure or tension to the cable harness. |
| <input type="checkbox"/> | Check the drive system, the light equipment and the brakes to make sure that they are fully functional and effective. |
| <input type="checkbox"/> | Adjust the headlight. |
| <input type="checkbox"/> | Set the drive system has to the national language and the appropriate system of measurement. |
| <input type="checkbox"/> | Check the software version of the drive system and update it as necessary. |
| <input type="checkbox"/> | Take a test drive to check the brake system, gear shift and the electric drive system. |

5.3.4.1

**Checking the battery****Risk of fire and explosion due to faulty battery**

The safety electronics on damaged or faulty batteries may fail. The residual voltage can cause a short circuit. The batteries may self-ignite and explode.

- ▶ Never charge a defective battery.

The battery needs to be checked before it is charged for the first time.

- ▶ Press the *On-Off button (battery)*.
- ⇒ If none of the LEDs on the operating and charge status indicator light up, the battery may be damaged.
- ⇒ The battery can be charged if at least one of the LEDs on the operating and charge status indicator is fully lit up, but not if all of them are.
- ▶ Once the battery has been charged, insert the battery on the bicycle.

5.3.5

Mounting the wheel

5.3.5.1

Mounting the wheel with screw-on axle (15 mm) *Alternative*

- ▶ Insert the axle completely on the drive side.

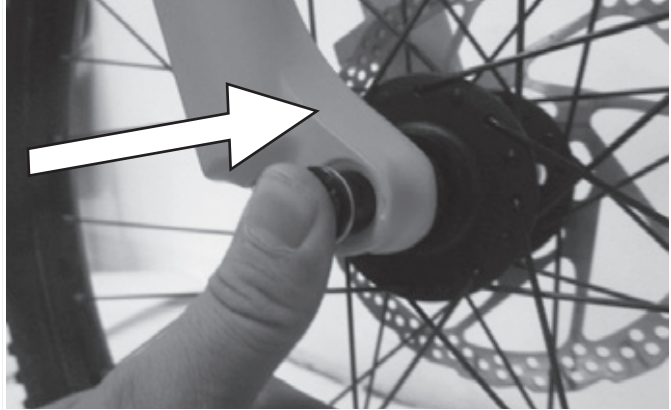

Figure 20:

Fully inserting the axle

- ▶ Tighten the axle with a 5 mm hexagon socket spanner to 8–10 Nm.

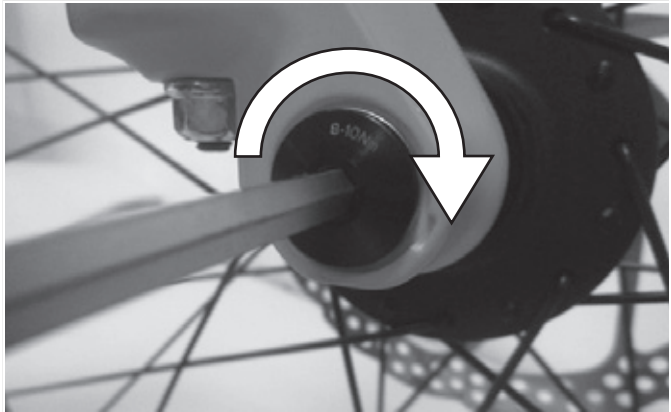

Figure 21:

Tightening the axle

► Insert the securing screw on the non-drive side.

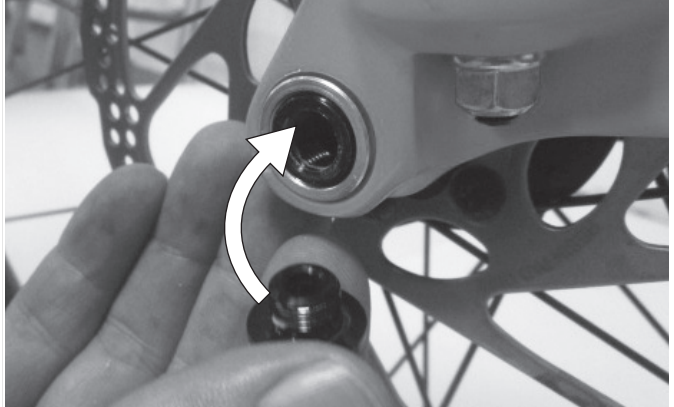

Figure 22:

Pushing the quick release lever into the axle

► Tighten the securing screw with a 5 mm hexagon socket spanner to 5–6 Nm.

⇒ The lever is mounted

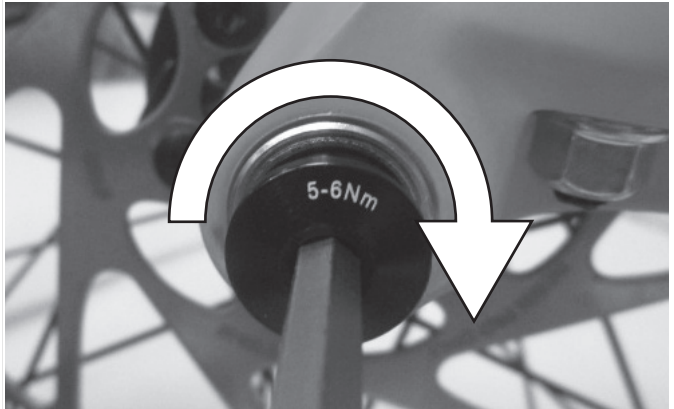

Figure 23:

Tightening the securing screw

5.3.5.2

Mounting the wheel with screw-on axle (20 mm) *Alternative*

- ▶ Insert the axle completely on the drive side.

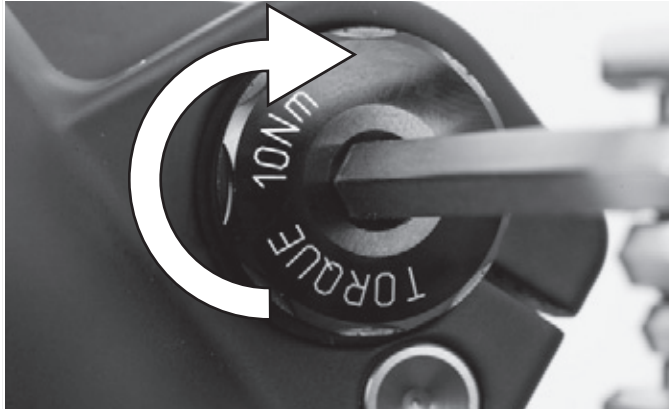

Figure 24:

Tightening the inserted axle

- ▶ Tighten the securing clip with a 4 mm hexagon socket spanner to 7 Nm.



Figure 25:

Tightening the axle

5.3.5.3

Mounting the wheel with a quick release axle
Alternative**Crash due to loose quick release axle**

A faulty or incorrectly installed quick release axle may become caught in the brake disc and block the wheel. This will cause a crash.

- ▶ Never fit a defective quick release axle.

**Crash caused by faulty or incorrectly installed quick release axle**

The brake disc becomes very hot during operation. Parts of the quick release axle may become damaged as a result. The quick release axle becomes loose. This will result in a crash and injuries.

- ▶ The quick release axle and the brake disc must be opposite one another.

**Crash caused by incorrectly set quick release axle**

Insufficient clamping force will cause a detrimental transmission of force. The suspension fork or the quick release axle may break. This will result in a crash and injuries.

- ▶ Never fasten a quick release axle with a tool, such as a hammer or pliers.

- ▶ Insert the axle into the hub on the drive side.
Clamping version II

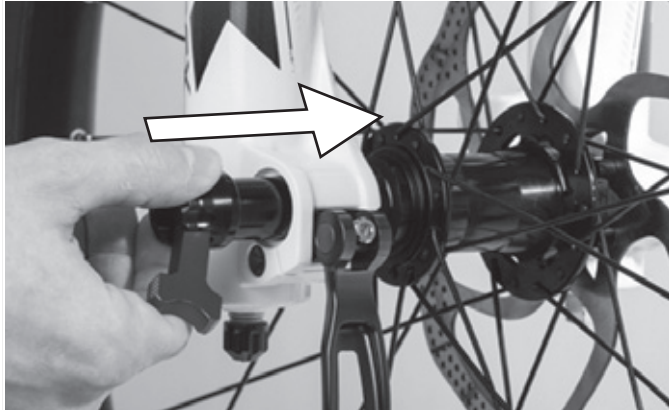

Figure 26: Pushing the axle into the hub

- ▶ Tighten the axle with the red handle.

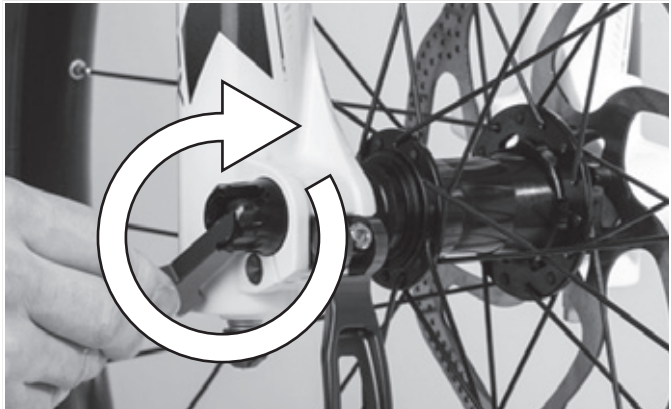

Figure 27: Tightening the axle

► Push the quick release lever into the axle.

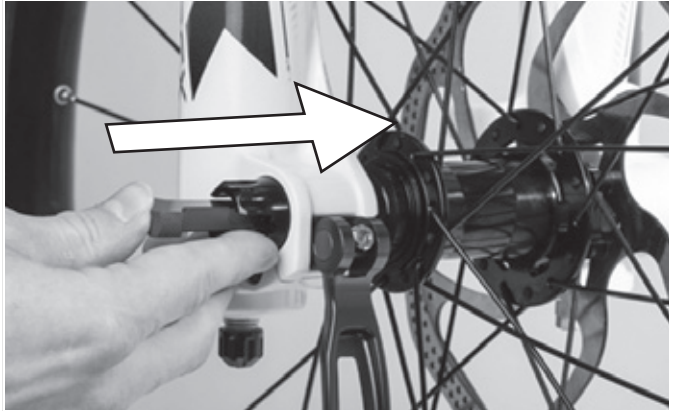

Figure 28:

Pushing the quick release lever into the axle

► Reverse the quick release lever.

⇒ The lever is secured.



Figure 29:

Securing the lever

- ▶ Check the position and clamping force of the quick release lever. The quick release lever must be flush with the lower housing. You must be able to see a slight impression on the palm of your hand when you close the quick release lever.



Figure 30:

Perfect position for the clamping lever

- ▶ Use a 4 mm hexagon socket spanner to adjust the clamping lever clamping force if required. Afterwards, check the quick release lever position and clamping force.

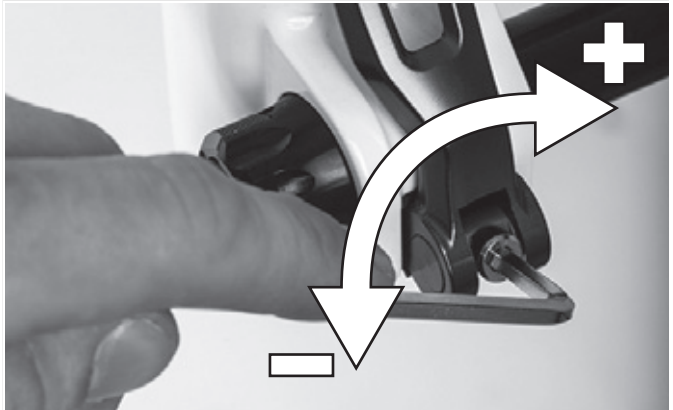

Figure 31:

Adjusting the quick release clamping force

5.3.6

Mounting the wheel with a quick release*Alternative***Crash caused by unfastened quick release**

A faulty or incorrectly installed quick release may become caught in the brake disc and block the wheel. This will cause a crash.

- ▶ Never fit a defective quick release.

**Crash caused by faulty or incorrectly installed quick release**

The brake disc becomes very hot during operation. Parts of the quick release may become damaged as a result. The quick release comes loose. This will result in a crash and injuries.

- ▶ The front wheel quick release lever and the brake disc must be situated on opposite sides.

**Crash caused by incorrectly set clamping force**

Excessively high clamping force will damage the quick release and cause it to lose its function.

Insufficient clamping force will cause a detrimental transmission of force. The suspension fork or the quick release may break. This will result in a crash and injuries.

- ▶ Never fasten a quick release using a tool (e.g. hammer or pliers).
- ▶ Only use the clamping lever with the specified set clamping force.

- ▶ Before mounting, ensure that the quick release flange is extended. Open the lever completely.

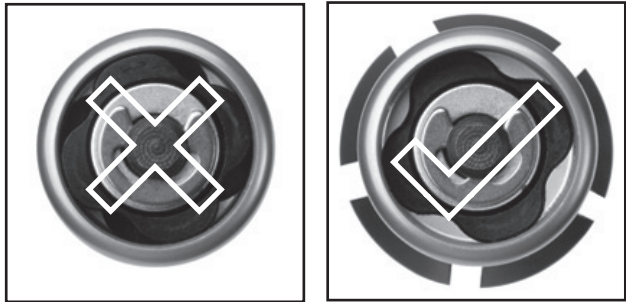

Figure 32:

Open and closed flange

- ▶ Push in the quick release until you hear a clicking sound. Make sure that the flange is extended.

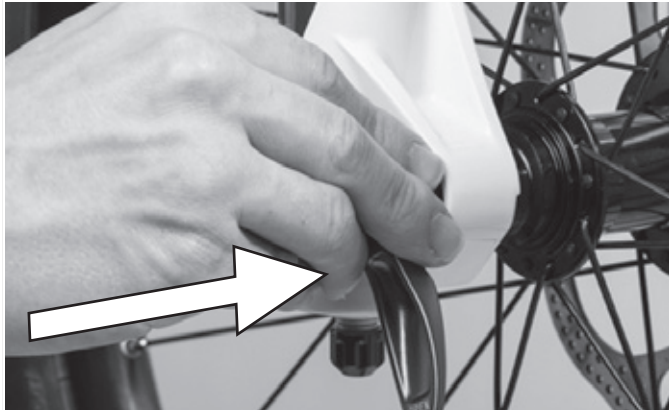

Figure 33:

Pushing the quick release in

- ▶ Adjust the clamping with a half-open clamping lever until the flange reaches the fork end.

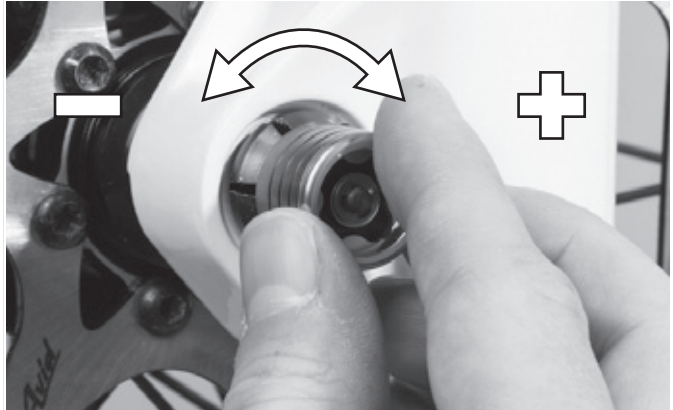

Figure 34:

Adjusting the clamping

- ▶ Fully close the quick release. Check the quick release to ensure it is firmly in place and adjust on the flange if necessary.

⇒ The lever is secured.



Figure 35:

Closing the quick release

5.3.6.1

Check stem and handlebars

Check connections

- ▶ Stand in front of the bicycle to check whether the handlebars, stem and fork shaft are firmly attached to one another. Clamp the front wheel between your legs. Grasp the handlebar grips. Try to twist the handlebars towards the front wheel.

⇒ The stem must not move or twist.

Firm hold

- ▶ Place your entire body weight on the handlebars with the quick release lever closed to check that the stem is firmly in place.

⇒ The handlebars shaft must not move downwards in the fork shaft.

- ▶ If the handlebars shaft should move in the fork shaft, increase the quick release lever tensioning. To do so, turn the knurled nut slightly in a clockwise direction with the quick release lever open.

- ▶ Close the lever and check the stem is firmly in position.

Checking the headset backlash

- ▶ To check the handlebar headset backlash, close the quick release lever on the stem. Place the fingers of one hand on the upper headset cup, pull the front wheel brake with the other hand and try to push the bicycle backwards and forwards.
- ▶ The headset cup halves must not move towards one another while you are doing this. Note that there may be noticeable backlash due to worn-out bearing bushes or brake lining backlash in suspension forks and disc brakes.
- ▶ If there is headset backlash in the steering headset, you must adjust it as soon as possible; otherwise, the headset will become damaged. You must make the adjustment as described in the stem manual.

5.3.7

Sale of the bicycle

- ▶ Fill out the data sheet on the first page of the operating instructions.
- ▶ Adjust the bicycle to the rider.
- ▶ Set the *stand* and the *shifter*, and show the purchaser the settings.
- ▶ Instruct the operator or rider how to use all the functions of the bicycle.

6 Before the first ride



Crash due to incorrectly adjusted torques

If a screw is fastened too tightly, it may break. If a screw is not fastened enough, it may loosen. This will result in a crash and injuries.

- ▶ Always observe the indicated torques on the screw or in the operating instructions.

Only a correctly adjusted bicycle will guarantee you the desired ride comfort and health-promoting activity. Therefore adjust the *saddle*, the *handlebars* and the *suspension* to your body and your preferred riding style before the first ride.

6.1 Adjusting the saddle

6.1.1 Adjusting the saddle tilt

The saddle tilt must be adjusted to the seat height, the saddle and handlebar position, and the saddle shape to ensure an optimum fit. The seating position can be optimised in this way if needed. First, readjust the saddle after finding the handlebar position you prefer.

- ⇒ Place the saddle tilt in the horizontal position to adjust the bicycle to your needs for the first time.

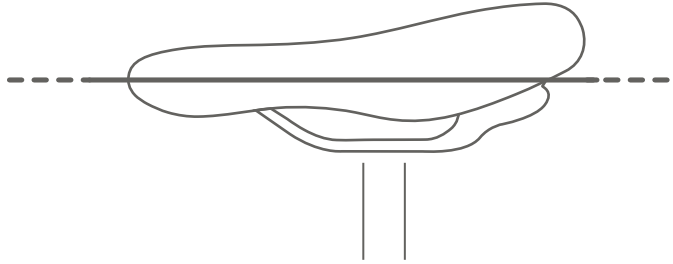

Figure 36:

Horizontal saddle tilt

6.1.2

Determining the seat height

- ✓ To determine the seat height safely, either push the bicycle near to a wall, so that you can lean on the wall to support yourself or ask another person to hold the bicycle for you.
- ▶ Climb onto the bicycle.
- ▶ Place your heel on the pedal and extend your leg, so that the pedal is at the lowest crank rotation point.
- ⇒ The rider sits straight on the saddle if the seat is at an optimum height. If this is not the case, you can adjust the length of the seat post to your needs.

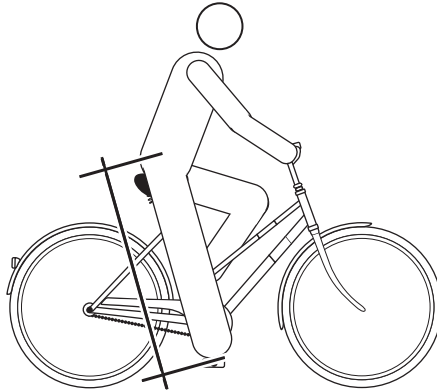

Figure 37: Optimal saddle height

6.1.3 Adjusting the seat height with quick release

- Open the quick release on the seat post to change the seat height. To do so, pull the clamping lever away from the seat post.

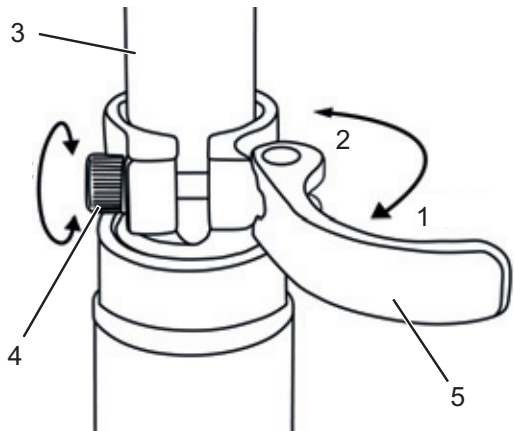

Figure 38: Seat post quick release (3) with clamping lever (5) and adjustment screw (4) in the open position (1) and in the direction of the closed position (2)

- ▶ Set the seat post at the required height.



Crash caused by an excessively high seat post setting

A *seat post* with is set too high will cause the *seat post* or the *frame* to break. This will result in a crash and injuries.

- ▶ Do not pull the seat post out of the frame beyond the minimum insertion depth marking.

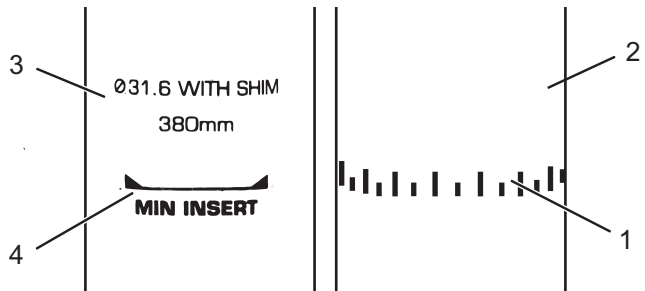

Figure 39:

Detailed view of the seat post – examples of the minimum insertion depth marking

- ▶ To close it, push the *seat post clamping lever* as far as it will go into the *seat post*.
- ▶ Check the *clamping force of the quick releases*.

6.1.4

Setting the height-adjustable seat post

- ▶ When using your seat post for the first time, you must give it a firm push downwards to set it in motion. This is due to the natural tendency of the seal to repel oil from the seal surface. You only need to do this before the first use or after a longer period of non-use. Once you have displaced the post through its deflection, the oil spreads on the seal and the post begins to function normally.

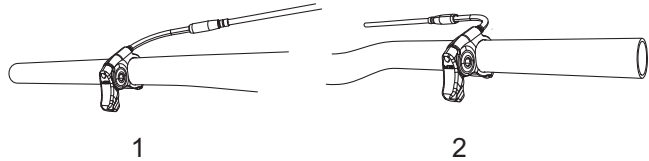

Figure 40: The seat post activation lever can be mounted either on the left (1) or the right (2) side of the handlebars

6.1.4.1 Lowering the saddle

- ✓ To lower the saddle, press your hand down on the saddle or sit on the saddle.
- ▶ Press the seat post activation lever and hold it down.
- ▶ Release the lever once you have reached the required height.

6.1.4.2 Raising the saddle

- ▶ Pull the seat post activation lever.
- ▶ Remove any pressure on the saddle and release the lever once you have reached the required height.

6.1.5

Adjusting the seat position

The saddle can be shifted on the saddle frame. The right horizontal position ensures an optimal leverage position for legs. This prevents knee pain and painful incorrect pelvis positions. If you have displaced the saddle more than 10 mm, you then need to adjust the saddle height again since both settings affect one another.

- ✓ To adjust the seat position safely, either push the bicycle near to a wall, so that you can lean on the wall to support yourself or ask another person to hold the bicycle for you.
- ▶ Climb onto the bicycle.
- ▶ Place the pedals into the vertical position (3 o'clock position) with your feet.
- ⇒ The rider is sitting in the optimal sitting position if the knee cap perpendicular line runs through the pedal axle. If the perpendicular line crosses behind the pedal, bring the saddle forward. If the perpendicular line crosses in front of the pedal, bring the saddle back. Move the saddle within its permitted displacement range only (marked on the saddle stay).

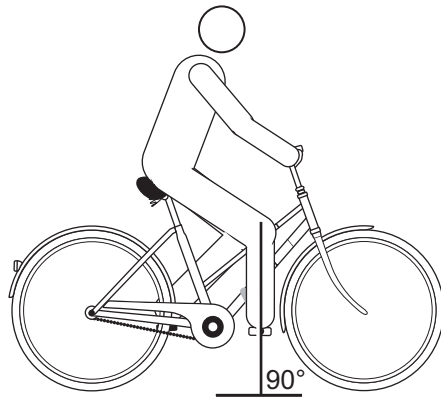

Figure 41:

Knee cap perpendicular line

6.2

Setting the handlebars

- ✓ The handlebars must only be adjusted while the bicycle is stationary.
- ▶ Unfasten and adjust the designated screw connections, and clamp them with the maximum tightening torque for the clamping screws of the handlebars.

Maximum tightening torque for the clamping screws of the handlebars*

5 Nm - 7 Nm

*if there is no other data on the component

Table 28:

Handlebars clamping screw maximum tightening torque

Adjusting the stem**Crash caused by loose stem**

Incorrectly fastened screws may come loose due to impact. The stem may no longer be firmly fixed in its position as a result. This will result in a crash and injuries.

- ▶ Check the handlebars and the quick release system are firmly in position after the first two hours of riding.

6.2.1

Adjusting the handlebar height



Crash caused by incorrectly set clamping force

Excessively high clamping force will damage the quick release and cause it to lose its function. Insufficient clamping force will cause a detrimental transmission of force. This can cause components to break. This will result in a crash and injuries.

- ▶ Never fasten a quick release using a tool (e.g. hammer or pliers).
 - ▶ Only use the clamping lever with the specified set clamping force.
-
- ▶ Open the clamping lever.
 - ▶ Pull the locking lever on the stem up, and simultaneously pivot the handlebars into the desired position.
- ⇒ You feel the locking lever click into place.
- ▶ Pull out the handlebars to the required height.
 - ▶ Lock the quick release.

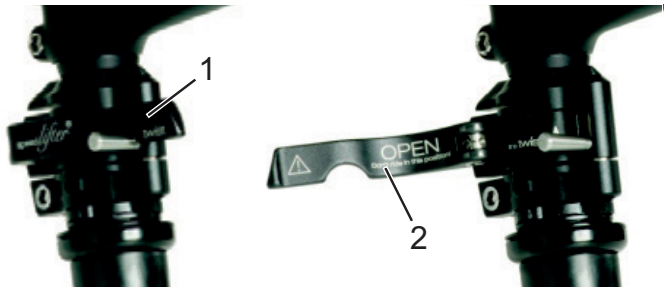

Figure 42:

Open (2) and closed (1) clamping lever on the stem – example: by.schulz speed lifter

6.2.2

Turning the handlebars to the side *Alternative*



Crash caused by incorrectly set clamping force

Excessively high clamping force will damage the quick release and cause it to lose its function.

Insufficient clamping force will cause a detrimental transmission of force. This will result in a crash and injuries.

- ▶ Never fasten a quick release using a tool (e.g. hammer or pliers).
- ▶ Only use the clamping lever with the specified set clamping force.

-
- ▶ Open the clamping lever.
 - ▶ Pull the locking lever on the stem up, and simultaneously pivot the handlebars into the desired position.
- ⇒ You feel the locking lever click into place.
- ▶ Pull out the handlebars to the required height.
 - ▶ Lock the quick release.

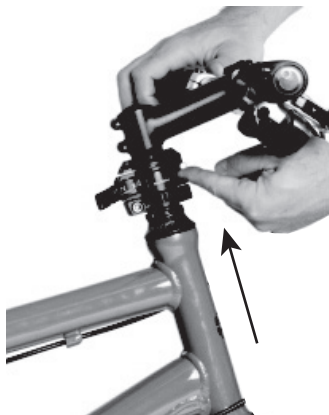

Figure 43:

Pulling locking lever upwards – example: by.schulz speed lifter

6.2.2.1

Checking the clamping force of the quick releases

- ▶ Open and close the quick releases on the stem or the seat post.
- ⇒ The clamping force is sufficient if the clamping lever can be moved easily from the open final position into the middle and has to be pressed with the fingers or base of the thumb from the middle point onwards.

6.2.2.2

Adjusting the quick release clamping force

- ▶ If the *clamping lever on the handlebars* cannot be moved into its final position, screw out the *knurled nut*.
- ▶ Tighten the *knurled nut* on the seat post if the *clamping lever's* clamping force is not sufficient.



If you are unable to set the clamping force, the specialist dealer will need to check the quick release.

6.3

Adjusting the brake lever

6.3.1

Adjusting the pressure point on a Magura brake lever



Brake failure due to incorrect setting

If the pressure point is set with brakes where the brake lining and brake disc have reached their wear limit, the brakes may fail and cause an accident with injury.

- ▶ Before you set the pressure point, ensure that the brake lining and brake disc have not reached their wear limit.
-

The pressure point setting is adjusted using the twist knob.

- ▶ Turn the twist knob towards the plus (+) symbol.
- ⇒ The brake lever moves closer to the handlebar grip. Re-adjust the grip distance as necessary.
- ⇒ The lever pressure point activates sooner.

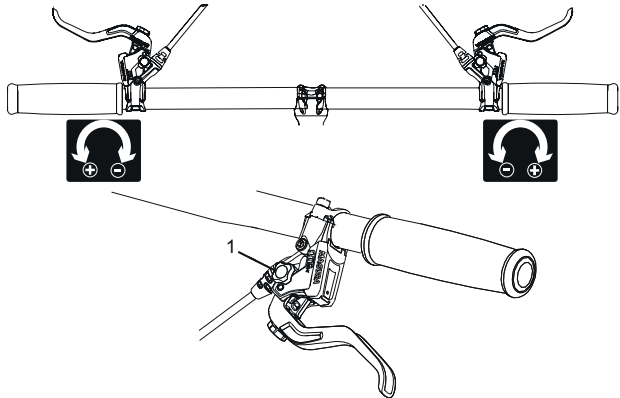

Figure 44:

Using the twist knob (1) to adjust the pressure point

6.3.2

Adjusting the grip distance



Crash caused by incorrectly set grip distance

If brake cylinders are set incorrectly or installed wrongly, the braking power may be lost at any time. Such damage may cause you to fall from the bicycle and injure yourself.

- ▶ Once the grip distance has been set, check the position of the brake cylinder and adjust it as necessary.
- ▶ Never correct the brake cylinder position without special tools. Have a specialist dealer correct it.



The brake lever grip distance can be adjusted to ensure that it can be reached more easily. Contact your specialist dealer if the brake handle is too far from the handlebars or is hard to use.

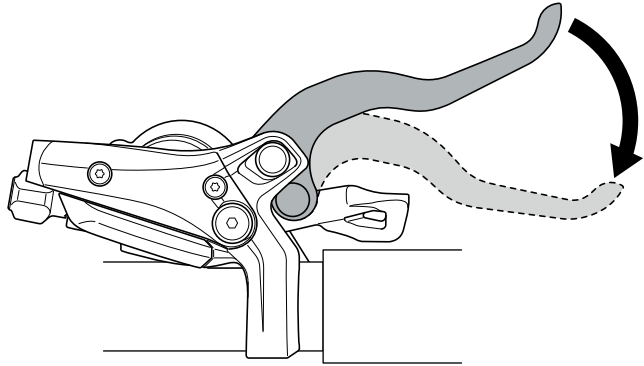

Figure 45: Brake lever grip distance

6.3.2.1 Adjusting the grip distance on a Magura brake lever (Alternative version)

Use a T25 TORX® wrench to turn the setting screw to adjust the grip distance.

- ▶ Turn the setting screw in the minus (-) direction.
⇒ The brake lever moves closer to the handlebar grip.
- ▶ Turn the setting screw in the plus (+) direction.
⇒ The brake lever moves away from the handlebar grip.

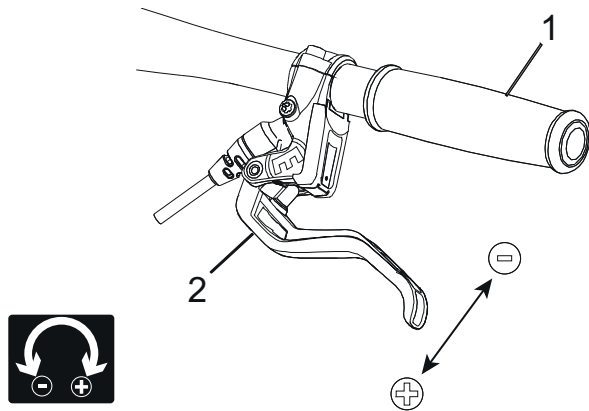

Figure 46:

Using the setting screw (2) to adjust the distance from the brake lever to the handlebar grip (1)

6.4

Adjusting the suspension



CAUTION

Crash caused by incorrectly set suspension

If the suspension is adjusted incorrectly, the fork may become damaged, so that problems may occur when steering. This will result in a crash and injuries.

- ▶ Never ride the bicycle without air in the air suspension fork.
 - ▶ Never use the bicycle without adjusting the suspension fork to the rider's weight.
-
- ▶ Settings on the chassis change riding performance significantly. You need to get used to the bicycle and break it in to prevent accidents.

NOTICE

The adjustment shown here represents a basic setting. The rider should change the basic setting to suit the surface and his/her preferences.

- ▶ It is advisable to make a note of the basic setting. This way, it can be used as the starting point for subsequent, optimised settings and to safeguard against unintentional changes.

6.4.1

Adjusting the negative deflection

Negative deflection is compression caused by the rider's weight, including equipment (such as a backpack), sitting position and frame geometry.

Each rider has a different weight and sitting position. Negative deflection depends on the rider's position and weight and should be between 15% and 30% of the maximum fork deflection, depending on the bicycle usage and preferences.

6.4.1.1

Adjusting the steel suspension fork negative deflection

Alternative

You can adjust the fork by tensioning the spring to the rider's weight and their preferred riding style. It is not the coil spring hardness which is adjusted; it is its pre-tensioning. This reduces the fork's negative deflection when the rider sits on the bicycle.



Figure 47:

Negative deflection setting wheel on the suspension fork crown

- ✓ Only adjust the negative deflection when the bicycle is stationary.
- ▶ The setting wheel may be located under a plastic cover on the suspension fork crown. Remove the plastic cover by pulling it off upwards.
- ▶ Turn the negative deflection setting wheel in a clockwise direction to increase the spring pre-tensioning.
Turn the negative deflection setting wheel in an anti-clockwise direction to reduce it.
- ⇒ The ideal setting in relation to the weight of the rider has been achieved when the shock absorber deflects 3 mm under the stationary load of the rider.
- ▶ If applicable, re-attach the plastic cover after setting the suspension fork.

6.4.1.2

Adjusting the air suspension fork negative deflection *Alternative*

NOTICE

Riding without filling pressure will destroy the wheel suspension, the frame and the air suspension elements.

- ▶ Never ride without filling pressure in the air suspension elements.

NOTICE

A normal air pump cannot build up the required pressure with sufficient sensitivity.

- ▶ Use a special damper pump to adjust the filling pressure.

The air chamber valve can be used to adjust the fork suspension to the rider's weight and driving style.

Adjusting the tyre pressure

- ▶ The tyre pressure determines the force required to press the fork together. If the tyre pressure is reduced, the fork slackens more and rebounds less.



Figure 48:

Screw caps in different designs

- ✓ Only adjust the tyre pressure when the bicycle is stationary.
- ▶ The air valve is located under a screw cap on the head of the left shock absorber. Unscrew and remove the screw cap.
- ▶ Adjust the air pressure as an initial value using a high-pressure damper pump and based on the tyre pressure table on the fork and the rider's weight.

6.5

Retracting brake linings

New brake linings take time to break in and adjust to their final braking force.

- ▶ Accelerate bicycle to about 25 km/h.
- ▶ Brake bicycle until it comes to a halt
- ▶ Repeat process 30–50 times.
- ▶ The brake linings and brake discs are now broken in and provide optimal braking power.

7

Operation

 **CAUTION****Crash caused by loose clothing**

Laces, scarves and other loose items may become entangled in the spokes on the *wheels* and the *chain drive*. Such damage may cause you to fall from the bicycle and injure yourself.

- ▶ Wear sturdy footwear and close-fitting clothing.
-

 **CAUTION****Crash caused by soiling**

Heavy soiling can impair the functions of the bicycle, for example, the function of the brakes. Such damage may cause you to fall from the bicycle and injure yourself.

- ▶ Remove coarse soiling before riding.
-

 **CAUTION****Crash caused by poor road conditions**

Loose objects, such as branches and twigs, may become caught in the wheels and cause a crash with injuries.

- ▶ Be aware of the road conditions.
 - ▶ Ride slowly and brake in good time.
-

NOTICE

When riding downhill, high speeds may be reached. The bicycle is only engineered for exceeding a speed of 25 km/h briefly. In particular the *tyres* can fail if exposed to a continuous load.

- ▶ Decelerate the bicycle with the brakes if higher speeds than 25 km/h are reached.
-

NOTICE

Heat or direct sunlight can cause the *tyre pressure* to increase above the permitted maximum pressure. This can destroy the *tyres*.

- ▶ Never park the bicycle in the sun.
 - ▶ On hot days, regularly check the *tyre pressure* and adjust it as necessary.
-

You can ride the bicycle within a temperature range between 5 °C and 35 °C. The effectiveness of the drive system is restricted outside of this temperature range.

Operation temperature

5 °C–35 °C

Moisture penetrating at low temperatures may impair individual bicycle functions due to the open structural design.

- ▶ Always keep the bicycle dry and free from frost.
- ▶ If the bicycle is to be used at temperatures below 3 °C, the specialist dealer must carry out an inspection and prepare the bicycle for winter usage first.



Off-road riding subjects the joints in the arms to severe strain. Take a break from riding every 30 to 90 minutes, depending on the condition of the roads.

7.1

Before each ride



CAUTION

Crash caused by difficult-to-spot damage

If the bicycle topples over or you have a fall or an accident, there may be difficult-to-spot damage to components such as the brake system, quick releases or *frame*. Such damage may cause you to fall from the bicycle and injure yourself.

- ▶ Take the bicycle out of service and have a specialist dealer carry out an inspection.
-



CAUTION

Crash caused by material fatigue

Intensive use can cause material fatigue. A component may suddenly fail in case of material fatigue. Such damage may cause you to fall from the bicycle and injure yourself.

- ▶ Remove the bicycle from service immediately in case of any signs of material fatigue. Have the specialist dealer check the state.
- ▶ Have the specialist dealer carry out a basic inspection regularly. During the inspection, the specialist dealer inspects the bicycle for any signs of material fatigue on the frame, fork, suspension element mountings (if there are any) and components made of composite materials.

Carbon becomes brittle when exposed to heat radiation such as heating. This can cause the carbon part to break and result in a crash with injuries.

- ▶ Never expose carbon parts to strong heat sources.
-

7.2

Check list before each ride

▶ Check the bicycle before each ride.

⇒ Do not use the bicycle if there are any anomalies.

<input type="checkbox"/>	Check that the bicycle is complete.
<input type="checkbox"/>	Check that the lighting, reflector and brake, for instance, are sufficiently clean.
<input type="checkbox"/>	You must check that the mudguards, the pannier rack and the chain guard are securely installed.
<input type="checkbox"/>	Check that the front and rear wheels run true. This is particularly important if the bicycle has been transported or secured with a lock.
<input type="checkbox"/>	Check the valves and the tyre pressure. Adjust as necessary before each ride.
<input type="checkbox"/>	If the bicycle has a hydraulic rim brake, check whether the locking levers are fully closed in their final positions.
<input type="checkbox"/>	Check the front and rear wheel brakes to make sure that they are working properly. To do so, operate the brake levers while stationary in order to check whether resistance is generated in the usual brake lever position. The brake must not lose any brake fluid.
<input type="checkbox"/>	Check that the driving light is working.
<input type="checkbox"/>	Check for unusual noises, vibrations, smells, staining, deformation, cracks, scores, abrasion and wear. This indicates material fatigue.
<input type="checkbox"/>	Inspect suspension system for cracks, dents, bumps, parts or leaking oil. Look at concealed sections on the bicycle's lower surfaces.
<input type="checkbox"/>	Use body weight to compress suspension system. If it feels too soft, adjust to the optimal sag setting.
<input type="checkbox"/>	If quick releases are used check them to make sure that they are fully closed in their end position. If quick release axle systems are used, make sure that all attachment screws are tightened to the correct torque.
<input type="checkbox"/>	Be alert to any unusual operating sensations when braking, pedalling or steering.

7.3**Using the kickstand**

**CAUTION****Crash caused by a lowered kickstand**

The kickstand does not fold up automatically. There is a risk of crashing if riding with the kickstand lowered.

- ▶ Raise the kickstand completely before the ride.

NOTICE

The heavy weight of the bicycle may cause the kickstand to sink into soft ground and the bicycle may topple and crash over.

- ▶ The bicycle must be parked on firm, level ground only.
 - ▶ It is particularly important to check that the bicycle is stable if it is equipped with accessories or loaded with luggage.
-

Raising the kickstand

- ▶ Before the ride, raise the kickstand completely with your foot.

Parking the bicycle

- ▶ Before parking, lower the kickstand completely with your foot.
- ▶ Park the bicycle carefully and check that it is stable.

7.4

Using the pannier rack



Crash caused by loaded pannier rack

The riding performance of the bicycle changes with a loaded *pannier rack*, in particular when steering and braking. This can lead to a loss of control. Such damage may cause you to fall from the bicycle and injure yourself.

- ▶ You should practice how to use a loaded *pannier rack* safely and reliably before using the bicycle in public spaces.



Crash caused by unsecured luggage

Loose or unsecured objects on the *pannier rack*, e.g. belts, may become caught in the rear wheel. Such damage may cause you to fall from the bicycle and injure yourself.

Objects which are fastened to the pannier rack may cover the bicycle's *reflectors* and the *driving light*. The bicycle may be overseen on public roads. Such damage may cause you to fall from the bicycle and injure yourself.

- ▶ Secure any objects which are attached to the *pannier rack* sufficiently.
- ▶ Objects fastened to the *pannier rack* must never cover the *reflectors*, the *headlight* or the *rear light*.



Crushing the fingers in the spring flap

The spring flap on the *pannier rack* operates with a high clamping force. There is a risk of crushing the fingers.

- ▶ Never allow the spring flap to snap shut in an uncontrolled manner.
 - ▶ Be careful where you position your fingers when closing the spring flap.
-

NOTICE

The maximum load bearing capacity is indicated on the *pannier rack*.

- ▶ Never exceed the permitted *total weight* when packing the bicycle.
 - ▶ Never exceed the maximum load bearing capacity of the *pannier rack*.
 - ▶ Never modify the *pannier rack*.
-
- ▶ Distribute the luggage as evenly as possible on the left and right-hand side of the bicycle.
 - ▶ We recommend the use of panniers and luggage baskets.

7.5

Battery



Risk of fire and explosion due to faulty battery

The safety electronics on damaged or faulty batteries may fail. The residual voltage can cause a short circuit. The batteries may self-ignite and explode.

- ▶ Remove batteries with external damage from service immediately and never charge them.
- ▶ If the battery becomes deformed or begins to smoke, keep at a safe distance, disconnect the power supply at the socket, and notify the fire service immediately.
- ▶ Never extinguish damaged batteries with water or allow them to come into contact with water.
- ▶ If a battery is dropped or struck but shows no signs of external damage, remove the battery from service and observe it for at least 24 hours.
- ▶ Faulty batteries are hazardous goods. Dispose of faulty batteries properly and as quickly as possible.
- ▶ Store in a dry place until disposal. Never store in the vicinity of flammable substances.
- ▶ Never open or repair the battery.



Risk of fire and explosion due to high temperatures

Excessively high temperatures damage the battery. The battery may self-ignite and explode.

- ▶ Protect battery against heat
 - ▶ Never expose the battery to sustained direct sunlight.
-



Fire and explosion caused by short circuit

Small metal objects may jumper the electrical connections of the battery. The batteries may self-ignite and explode.

- ▶ Keep paper clips, screws, coins, keys and other small parts away from the battery and do not insert them into the battery.



Chemical burns to the skin and eyes caused by faulty battery

Liquids and vapours may leak from damaged or faulty batteries. They can irritate the airways and cause burns.

- ▶ Avoid contact with leaked liquids.
- ▶ Ventilate with fresh air and consult a doctor if you suffer any pain or discomfort.
- ▶ Immediately consult a doctor in case of contact with the eyes or any discomfort.
- ▶ In case of contact with the skin, rinse off immediately with water.
- ▶ Ventilate the room well.



Fire and explosion caused by incorrect charger

Batteries which are charged with an unsuitable charger, may become internally damaged. This may result in fire or an explosion.

- ▶ Only ever use the battery with the supplied charger.
 - ▶ Mark the supplied charger and these operating instructions clearly to prevent mix-ups – with the *bicycle frame number* or *type number*, for example.
-



Fire and explosion caused by penetration by water

The battery is only protected from simple spray water. Penetration by water can cause a short circuit. The battery may self-ignite and explode.

- ▶ Never immerse the battery in water.
- ▶ If there is reason to believe that water may enter into the battery, the battery must be removed from service.

NOTICE

If a key is left inserted when transporting the bicycle, or when riding, it may break off or the compartment may open accidentally.

- ▶ Remove the key from the battery lock immediately after use.
 - ▶ We recommend that you attach the key to a key ring.
-

7.5.1

Down tube battery *Alternative*

- ✓ Before the battery is to be removed or inserted, switch off the battery and the drive system.

7.5.1.1

Removing the down tube battery

- ▶ (1) Open the battery lock with the key.
- ▶ Tip the down tube battery out of the top mount.
- ▶ (2) Pull the down tube battery out of the lower mount.

7.5.1.2

Inserting the down tube battery

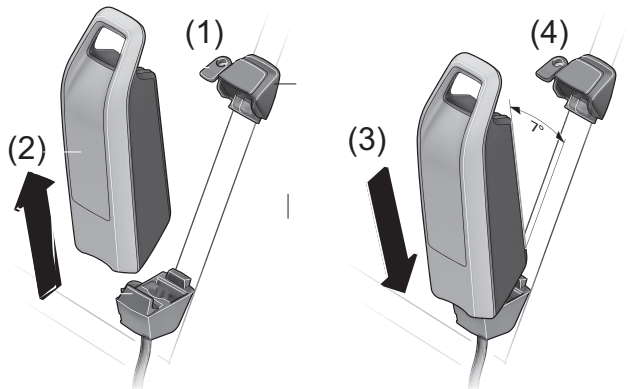

Figure 49:

Removing and inserting the down tube battery

- ▶ (3) Place the down tube battery on the contacts in the lower mount.
- ▶ (4) Remove the key from the lock.
- ▶ Tip the battery into the top mount as far as it will go.
⇒ There is an audible clicking noise.
- ▶ Check the inserted battery to make sure it is firmly in place.

7.5.2 Pannier rack battery *Alternative*

- ✓ Before the battery is to be removed or inserted, switch off the battery and the drive system.

7.5.2.1 Removing the pannier rack battery

- ▶ (1) Open the battery lock with the key.
- ▶ (2) Pull the pannier rack battery backwards and out of the *pannier rack battery mount*.
- ▶ Remove the key from the lock.

7.5.2.2 Inserting the pannier rack battery

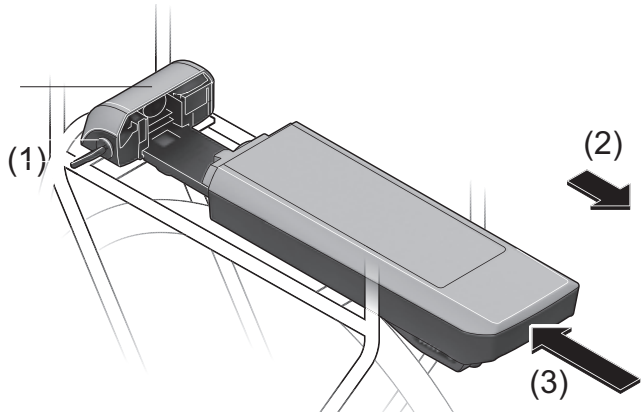

Figure 50: Removing and inserting the pannier rack battery

- ▶ (3) Insert the pannier rack battery into the *pannier rack battery mount* with the contacts first, so that it clicks into place.
- ▶ Check the inserted battery to make sure it is firmly in place.

7.5.3 Integrated battery *Alternative*

- ✓ Before the battery is to be removed or inserted, switch off the battery and the drive system.

7.5.3.1 Removing the integrated battery

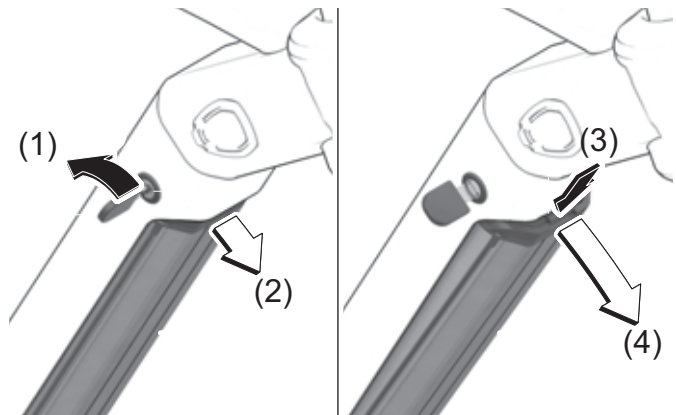

Figure 51: Removing the integrated battery

- ▶ (1) Open the battery lock with the key.
- ⇒ (2) The integrated battery is released and falls into the retainer guard.
- ▶ (3) Hold the battery in your hand from below. Use the other hand to push on the retainer guard from above.
- ⇒ (4) The integrated battery is fully released and will fall into your hand.
- ▶ Pull the integrated battery out of the frame.
- ▶ Remove the key from the lock.

7.5.3.2

Inserting the integrated battery

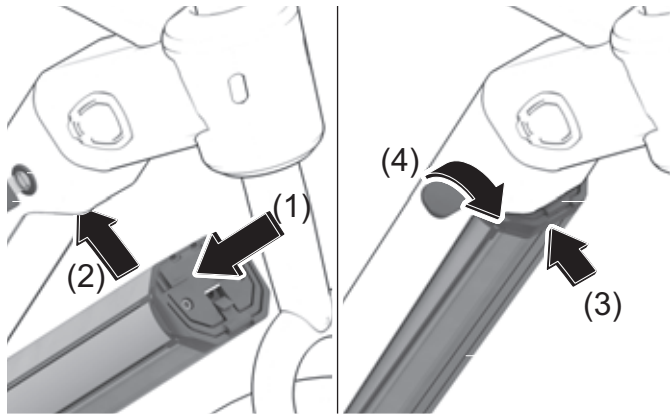

Figure 52: Inserting the integrated battery

- ▶ (1) Place the battery with the contacts first into the lower mount.
- ▶ (2) Tilt the integrated battery up, so that it is held by the retainer guard.
- ▶ (3) Push the integrated battery upwards, so that you hear it click into place.
- ▶ Check the inserted battery to make sure it is firmly in place.
- ▶ (4) Lock the battery with the key; otherwise, the battery may fall out of the mount when you open the lock.
- ▶ Remove the key from the lock.

7.5.4

Charging the battery



Risk of fire and explosion due to faulty battery

The safety electronics on damaged or faulty batteries may fail. The residual voltage can cause a short circuit. The batteries may self-ignite and explode.

- ▶ Never charge a defective battery.
-



Fire caused by overheated charger

The charger heats up when charging the battery. In case of insufficient cooling, this can result in fire or burns to the hands.

- ▶ Never use the charger on a highly flammable surface (e.g. paper, carpet etc.).
 - ▶ Never cover the charger during the charging process.
 - ▶ Never charge the battery unattended.
-



Electric shock caused by penetration by water

If water penetrates into the charger, there is a risk of electric shock.

- ▶ Never charge the battery outdoors.
-



Electric shock in case of damage

Damaged chargers, cables and plug connectors increase the risk of electric shock.

- ▶ Check the charger, cable and plug connector before each use. Never use a damaged charger.
 - ▶ If an error occurs during the charging process, a system message is displayed. Remove the charger and the battery from operation immediately and follow the instructions.
-

NOTICE

- ✓ The ambient temperature during the charging process must be within the range from 0 °C to 40 °C.
- ✓ The battery can remain on the bicycle or be removed for charging.
- ✓ Interrupting the charging process does not damage the battery.
- ✓ On a bicycle which is equipped with two batteries, the charging process for both batteries is started from the pannier rack battery.
- ▶ Remove the rubber cover from the battery.
- ▶ Connect the mains plug of the charger to a normal domestic, grounded socket.

Connection data

230 V, 50 Hz

- ▶ Connect the charging cable to the battery's charging port.
- ✓ The charging process starts automatically.
- ⇒ During the charging process the operating and charge status indicator indicates the charge status. When the drive system is switched on, the *display* shows the charging process.



- ⇒ If the battery is outside its charging temperature range, three LEDs will flash on the charge level indicator.

- ✓ Disconnect the battery from the charger and allow it to cool down. Do not connect the rechargeable battery to the charger again until the permitted charging temperature has been reached.
- ⇒ The charging process is complete when the LEDs of the operating and charge status indicator go out.
- ▶ Once charging is complete, disconnect the battery from the charger and the charger from the mains.

7.5.5

Charging the dual battery
Alternative **WARNING****Risk of fire and explosion due to faulty battery**

The safety electronics on damaged or faulty batteries may fail. The residual voltage can cause a short circuit. The batteries may self-ignite and explode.

- ▶ Never charge a defective battery.

 **CAUTION****Fire caused by overheated charger**

The charger heats up when charging the battery. In case of insufficient cooling, this can result in fire or burns to the hands.

- ▶ Never use the charger on a highly flammable surface (e.g. paper, carpet etc.).
- ▶ Never cover the charger during the charging process.
- ▶ Never charge the battery unattended.

 **CAUTION****Electric shock caused by penetration by water**

If water penetrates into the charger, there is a risk of electric shock.

- ▶ Never charge the battery outdoors.

 **CAUTION****Electric shock in case of damage**

Damaged chargers, cables and plug connectors increase the risk of electric shock.

- ▶ Check the charger, cable and plug connector before each use. Never use a damaged charger.

NOTICE

- ▶ If an error occurs during the charging process, a system message is displayed. Remove the charger and the battery from operation immediately and follow the instructions.

One of the charging sockets is not accessible or is closed with an end cap on bicycles with two batteries.

- ▶ Charge the batteries using the accessible charging socket only.
- ▶ Never open a closed charging socket. Charging via a pre-closed charging socket can cause irreparable damage.

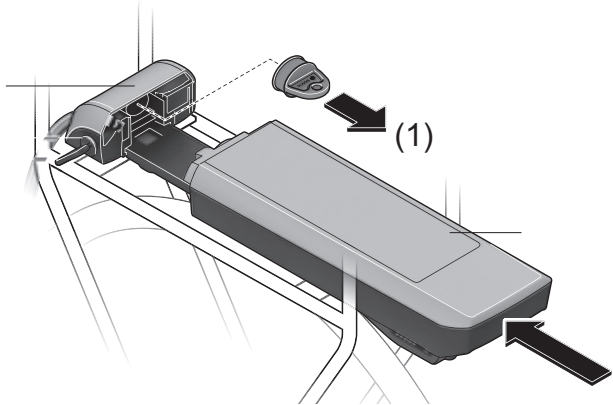

Figure 53:

Cover open contacts with cover cap – example: pannier rack battery

- ▶ (1) If you wish to use just one battery on a bicycle which is designed for two batteries, cover the contacts on the free slot with the supplied cover cap; otherwise, there is a risk of a short circuit caused by the open contacts.

7.5.5.1**Charging process when two batteries are used**

- ▶ If two batteries are attached to a bicycle, charge the two batteries via the non-closed socket.
- ⇒ The two batteries are charged alternately during the charging process. Charging switches automatically between the two batteries several times. The charging time is twice as long.

The two batteries are discharged alternately during use.

7.5.5.2**Charging process when one rechargeable battery is used**

If you remove the batteries out of their mounts, you can charge each battery individually.

If only one battery is used, you will only be able to charge the battery on the bicycle which has an accessible charging socket. You can only charge the battery with the closed charging socket if you remove it from its mount.

7.5.6**Waking the battery**

- ✓ When not used for a longer period, the battery switches to sleep mode for self-protection. The LEDs of the operating and charge status indicator do not light up.
- ▶ Press the *On-Off button (battery)*.
- ⇒ The battery's operating and charge status indicator indicates the charge status.

7.6 Electric drive system

7.6.1 Switching on the drive system



Crash caused by lack of readiness for braking

When it is switched on, the drive system can be activated by the application of force on the pedals. There is a risk of a crash if the drive is activated unintentionally, and the brake is not reached.

▶ Never start the electric drive system, or switch it off immediately, if the brake cannot be reached safely and reliably.

- ✓ A sufficiently charged battery has been inserted on the bicycle.
- ✓ The *display* has been inserted correctly into the mount.
- ✓ The battery is firmly in place. The key has been removed.

There are three options for switching on the drive system.

1 Battery On-Off button

▶ Press the **On-Off button (battery)** once.

2 Display On-Off button

▶ Press the **On-Off button (display)** once.

3 Switched-on display

▶ If the display is already switched on when it is inserted into its mount, the electric drive system is switched on automatically.

⇒ After switching on, a speed of 0 KM/H is displayed on the *display*. If this is not the case, you must check whether the *display* has been engaged properly in place.

- ⇒ If the drive system is switched on, the drive is activated as soon as the pedals are moved with sufficient force (except if in push assist mode or the level of assistance is "OFF").
- ⇒ The motor power is determined by the level of assistance set on the display.
- ⇒ As soon as the system has been activated, ACTIVE LINE/PERFORMANCE LINE appears briefly on the *display*.

7.6.2

Switching off the drive system

As soon as you stop pushing the pedals in normal mode or reach a speed of 25 km/h, the drive system switches off the assistance system. The assistance system starts up again if you push the pedals and your speed is less than 25 km/h.

The system switches off automatically ten minutes after the last command. There are three options for switching off the drive system manually.

1 Display On-Off key

- ▶ Press the **On-Off button** (display) once.

2 Battery On-Off key

- ▶ Press the **On-Off button (battery)**.

3 Removing the display

- ▶ Remove the *display* from the mount.
- ⇒ The LEDs of the operating and charge status indicator go out.

7.6.3

Switching on the drive system from the control panel with display



Crash caused by lack of readiness for braking

When it is switched on, the drive system can be activated by the application of force on the pedals. There is a risk of a crash if the drive is activated unintentionally, and the brake is not reached.

▶ Never start the electric drive system, or switch it off immediately, if the brake cannot be reached safely and reliably.

- ✓ A sufficiently charged battery has been inserted on the bicycle.
- ✓ The battery is firmly in place. The key has been removed.
- ✓ After switching off, the drive system shuts down. It is not possible to switch back on immediately. Wait a moment as necessary.

There are two options for switching on the drive system.

1 On-Off button (battery)

▶ Press the **On-Off button (battery)** once.

2 On-Off button (control panel with display)

▶ Press the **On-Off button (control panel with display)** once.

⇒ If the drive system is switched on, the drive is activated as soon as the pedals are moved with sufficient force.

7.6.4

Switching off the drive system

The system switches off automatically ten minutes after the last command. There are two options for switching off the drive system manually.

1 On-Off key (control panel with display)

- ▶ Press the **On-Off button (control panel with display)** once.

2 On-Off key (battery)

- ▶ Press the **On-Off button (battery)**.

7.7

Screen



Crash due to distraction

A lack of concentration while riding increases the risk of an accident. This may cause a crash with serious injuries as a consequence.

- ▶ Never allow yourself to be distracted by the display.
 - ▶ Stop bicycle if you want to make inputs on the display other than a change in level of assistance. Only enter data when the bicycle is stationary.
-

NOTICE

- ▶ Do not use the display as a handle. You may irreparably damage the display if you use it to lift the bicycle.
-

NOTICE

- ▶ If you do not use your bicycle for several weeks, remove the display from its mount. Store the display safely at room temperature in a dry environment.
-

NOTICE

The internal display battery discharges when it is not in use. This can cause damage to the internal display battery.

- ▶ Charge the internal display battery every 3 months for at least 1 hour.
-

7.7.1

Removing and attaching the display

NOTICE

If the rider is not present, the display can be used without authorisation, e.g. it may be stolen, the system settings may be changed or journey information may be read.

- ▶ Remove the display when the bicycle is parked.
-

The system is switched off by removing the display.

Removing the display

- ▶ Push the **display catch** down and simultaneously push the display forwards and out of the mount.

Attaching the display

- ▶ Place the display on the mount.
- ▶ Push the display back as far as it will go.

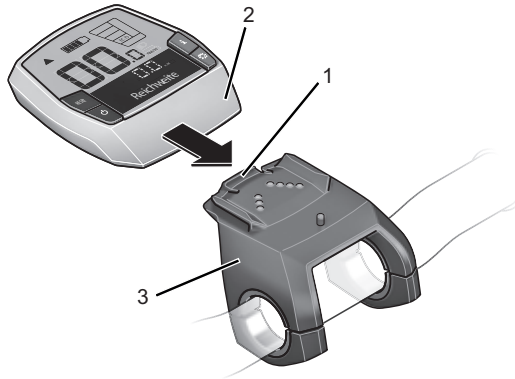

Figure 54:

Push display (2) over the display catch (1) until it locks into the mount (3)

7.7.2

Securing display against removal

NOTICE

- ▶ The blocking screw does not offer protection against theft
- ▶ Detach the display mount from the handlebars.
- ▶ Position the on-board computer in its mount.
- ▶ Fasten the blocking screw (M3 thread, 8 mm in length) into the designated thread in the mount from below
- ▶ Fit the mount to the handlebars.

7.7.3

Charging the internal display battery

NOTICE

The internal display battery discharges when it is not used. This can cause damage to the internal display battery.

- ▶ Charge the internal display battery every 3 months for at least 1 hour.
-
- ✓ If the internal display battery is low when switching on the display, ATTACH TO BIKE appears for three seconds in the text display. The display then switches back off.

There are two options for charging the battery.

1 Charging on the bicycle

- ▶ When a battery has been inserted on the bicycle, place the display in the mount for the display,
- ▶ Press the **On-Off button (battery)**.
- ▶ Use the bicycle.

2 Charging using the USB port

- ▶ Open the protective flap on the USB port.
- ▶ Connect the USB port to a commercially available USB charger or the USB port on a computer (5 V charge voltage; max. 500 mA charge current), using a suitable USB cable.
- ✓ USB CONNECTED is displayed on the display.

7.7.4 Using the USB port

NOTICE

Any moisture which enters through the USB port may trigger a short circuit in the display.

- ▶ Regularly check the position of the rubber cover on the USB port and adjust it as necessary.

The USB port can be used to operate external devices which can be connected using a standard micro A/ micro B USB 2.0 cable.

- ▶ Open the protective flap on the USB port.
- ▶ Replace the protective flap after using the USB port.

7.7.5 Switching on the display

- ▶ Press the **On-Off button (display)** briefly once.
⇒ The electric drive system is switched on.

7.7.6 Switch off screen

If the display is not inserted into the bracket, it will switch off automatically after one minute to save energy if no button is pressed.

- ▶ Press the **On-Off button (display)** briefly once.
⇒ The electric drive system is switched off.

7.7.7

Using the push assist



Injury from pedals or wheels

The pedals and the drive wheel turn when the push assist system is used. There is a risk of injury if the bicycle wheels are not in contact with the ground when the push assist system is used (e.g. when carrying the bicycle up stairs or when loading a bike rack).

- ▶ Only use the push assist mode when pushing the bicycle.
- ▶ You must steer the bicycle securely with both hands when using push assist.
- ▶ Allow for enough freedom of movement for the pedals.

The push assist helps the rider to push the bicycle. The speed can be a maximum of 6 km/h in this case.

- ✓ The tractive power of the push assist and its speed can be influenced by the selection of gear. To spare the drive, first gear is recommended for travelling uphill.
- ✓ The level of assistance OFF must not be selected.
- ▶ Press the **push assist button** once to activate the push assist.
- ▶ Press and hold the **plus button** within 3 seconds to switch on the push assist.
- ▶ Release the **plus button** to shut off the push assist. The push assist system switches off automatically as soon as the bicycle wheels are blocked or the speed exceeds 6 km.

7.7.8 Using the driving light

- ✓ The drive system needs to be already switched on to turn on the *driving light*.
- ▶ Press the **driving light button**.
- ⇒ The *driving light* is switched on (*driving light symbol* is displayed) or switched off (*driving light symbol* is not displayed).

7.7.9 Selecting the level of assistance

- ▶ Press the **plus button** to increase the level of assistance.
- ▶ Press the **minus button** to reduce the level of assistance.

7.7.10 Journey information

The displayed *journey information* can be changed and partially reset.

If the on-board computer is removed from its mount, all function values are saved and can still be displayed.

7.7.10.1 Changing the displayed journey information

- ▶ Press the **info button (display)** or **info button (operating element)** repeatedly until the required *journey information* is displayed.

7.7.10.2 Resetting the journey information

- ▶ If you wish to reset the *Trip Distance*, *Trip Time* and *Avg Speed* in journey information, switch to one of these three functions and then press the **RESET button** until the indicator is reset to zero. This will also reset the readings for the other two functions.

- ▶ If you wish to reset the maximum journey information, switch to this function and then press the **RESET button** until the indicator is reset to zero.
- ▶ If you wish to reset the *Range* journey information, switch to this function and then press the **RESET button** until the indicator is reset to factory setting.

7.7.11

Changing the system settings

System settings screen displays and changes are possible regardless of whether the display is inserted into the mount or not. A few settings are only visible and changeable if the display is inserted. A few menu items may be missing depending on the bicycle's features.

The *System settings* can be changed.

- ▶ Press the **info button (display)** and the **RESET button** together.
- ⇒ CONFIGURATION is displayed on the display. The *System settings* is open.
- ▶ Press the **info button (display)** repeatedly until the system setting which you wish to change is displayed.
- ▶ Press the **plus button** or the **minus button** to change the displayed setting.
- ▶ Press and hold the **RESET button** for 3 seconds to save the changed **system settings** and return to the **journey information**.

screen display	Change
- CLOCK +	You can set the current time. If you press on the setting buttons for a longer period of time, the time will be changed faster.
- WHEEL CIRCUM +	You can change the value that the manufacturer pre-set by $\pm 5\%$. This menu option is only shown if the display is in its mount.
- ENGLISH +	You can change the language for on-screen messages. You can choose between English, German, French, Spanish, Italian, Portuguese, Swedish, Dutch and Danish.
- UNIT KM/MI +	You can display the speed and distance in kilometres or miles.
- TIME FORMAT +	You can display the time in 12-hour or 24-hour format.
- SHIFT RECOM. OFF +	You can turn the gear recommendation screen display on or off.

Table 29:

Changing the system settings

7.8

Gear shift

The selection of the appropriate gear is a prerequisite for a physically comfortable ride and making sure that the electric drive system functions properly. The ideal pedalling frequency is between 70 and 80 revolutions per minute.

- ▶ It is advisable to stop pedalling briefly when changing gears. This makes it easier to switch gears and reduces wear on the drivetrain.

7.8.1

Selecting gears

The speed and range can be increased while applying the same force if you select the right gear. A gear recommendation is shown on the display to help you select.

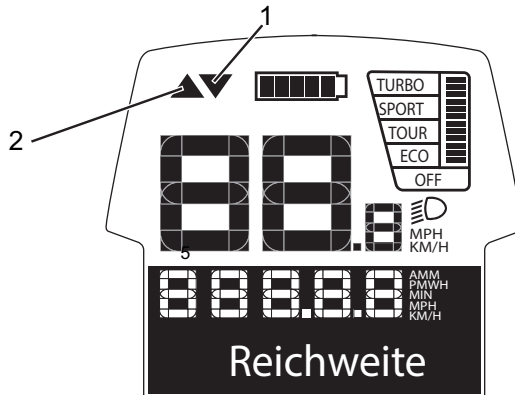

Figure 55:

Display with high (2) and low (1) gear recommendation

- ▶ If the gear recommendation is shown high, you should shift to a higher gear with a lower pedalling frequency.
- ▶ If the gear recommendation is shown low, you should shift to a lower gear with a higher pedalling frequency.

7.8.2

**Using derailleur gears
Alternative**

Figure 56:

Down shifter (1) and up shifter (2) on the left (I) and right (II) shift

- ▶ Select the appropriate gear with the *shifter*.
- ⇒ The gear shift switches the gear.
- ⇒ The shifter returns to its original position.
- ▶ Clean the rear derailleur if the gear change blocks.

7.8.3

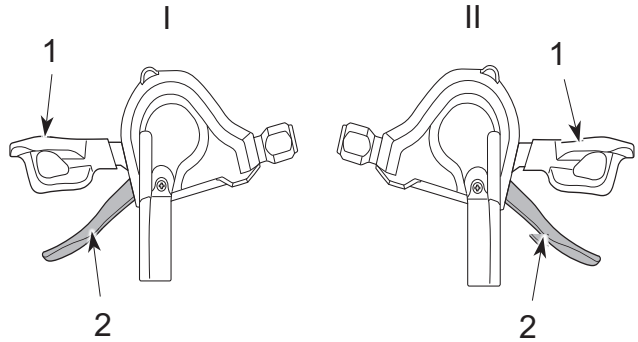
Using a hub gear *Alternative*



CAUTION

Crash caused by incorrect use

If the rider applies too much pressure on the pedals during a gear change and activates the shifter or changes several gears at a time, their feet may slip from the pedals. The bicycle may flip over or fall, which may cause injuries.

Switching down several gears to a low gear may cause the twist grip outer sleeve to suddenly come off. This will not have an adverse effect on the twist grip's correct functioning since the outer guide returns to its original position after the gear change is complete.

- ▶ Apply little pressure on the pedals while changing gears.
 - ▶ Never change more than one gear at a time.
-

NOTICE

The interior hub is not completely waterproof. If water gets into the hub, it may rust and the gear switch function may no longer function as a result.

- ▶ Never use the bicycle in places where water may get into the hub.
-

NOTICE

In rare cases, noises may be heard from the rear derailleur in the hub interior after a gear change. This is normal when gears are changed.

NOTICE

Do not detach the hub. If you need to detach it, contact your dealer.

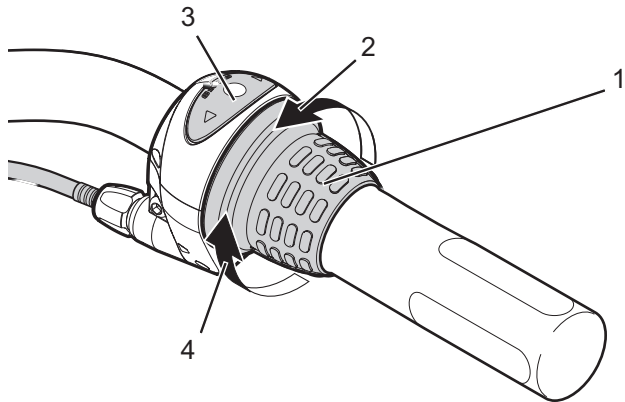

Figure 57:

Example; Shimano Nexus gear shift: twist grip (1) for the hub gear with its screen (3), the direction of rotation to switch up a gear (2) and the direction of rotation to switch down a gear (4)

- ▶ Turn the twist grip.
- ⇒ The gear shift switches the gear.
- ⇒ The number on the screen display shows the changed gear.

7.9

Brake



Hydraulic fluid can be fatal if it is swallowed and penetrates into the respiratory system

Hydraulic fluid may leak out after an accident or due to material fatigue. Hydraulic fluid can be fatal if swallowed and inhaled.

First aid treatment

- ▶ Wear gloves and safety goggles as protective equipment. Keep unprotected persons away.
- ▶ Remove those affected from the danger area to fresh air. Never leave those affected unattended.
- ▶ Ensure sufficient ventilation.
- ▶ Immediately remove clothing items contaminated with hydraulic fluid.
- ▶ Serious slip hazard due to hydraulic fluid leakage.
- ▶ Keep away from naked flames, hot surfaces and sources of ignition.
- ▶ Avoid contact with skin and eyes.
- ▶ Do not inhale vapours or aerosols.

After inhalation

- ▶ Take in fresh air; consult doctor if any pain or discomfort.

After skin contact

- ▶ Wash affected skin with soap and water and rinse well. Remove contaminated clothing. Consult doctor if any pain or discomfort.
-

After contact with eyes

- ▶ Rinse eyes under flowing water for at least ten minutes with the lids open; also rinse under lids. Consult eye doctor if pain or discomfort continues.

After ingestion

- ▶ Rinse out mouth with water Never induce vomiting! Risk of aspiration!
- ▶ Place a person lying on their back who is vomiting in a stable recovery position on their side. Seek medical advice immediately.

Environmental protection measures

- ▶ Never allow hydraulic fluid to flow into the sewage system, surface water or groundwater.
- ▶ Notify the relevant authorities if fluid penetrates the ground or pollutes water bodies or the sewage system.



Amputation due to rotating brake disc

The brake disc in disc brakes is so sharp that it can cause serious injuries to fingers if they are inserted into the disc brake openings.

- ▶ Always keep fingers well away from the rotating brake disc.
-



WARNING

Crash caused by brake failure

Oil or lubricant on the brake disc in a disc brake or on the rim of a rim brake can cause the brake to fail completely. This may cause a crash with serious injuries as a consequence.

- ▶ Never allow oil or lubricant to come into contact with the brake disc or brake linings or on the rim of a rim brake.
- ▶ If the brake linings have come into contact with oil or lubricant, contact a dealer or a workshop to have the components cleaned or replaced.

If the brakes are applied continuously for a long time (e.g. while riding downhill for a long time), the fluid in the brake system may heat up. This may create a vapour bubble. This will cause air bubbles or any water contained in the brake system to expand. This may suddenly make the lever travel wider. This may cause a crash with serious injuries.

- ▶ Release the brake regularly when riding downhill for a longer period of time.



CAUTION

Crash caused by wet conditions

The *tyres* may slip on wet roads. In wet conditions you must also expect a longer braking distance. The braking sensation differs from the usual sensation. This can cause loss of control or a crash, which may result in injuries.

- ▶ Ride slowly and brake in good time.
-



Crash caused by incorrect use

Handling the brake improperly can lead to loss of control or crashes, which may result in injuries.

- ▶ Shift your body weight back and down as far as possible.
- ▶ Practise braking and emergency braking before the bicycle is used in public spaces.
- ▶ Never use the bicycle if you can feel no resistance when pulling on the brake handle. Consult a specialist dealer.



Crash after cleaning or storage

The brake system is not designed for use on a bicycle which is placed on its side or turned upside down. The brake may not function correctly as a result. This can cause a crash, which may result in injuries.

- ▶ If the bicycle is placed on its side or turned upside down, apply the brake a couple of times before setting off to ensure that it functions normally.
- ▶ Never use the bicycle if it no longer brakes as normal. Consult a specialist dealer.



Burns caused by heated brake

The brakes may become very hot during operation. There is a risk of burns or fire in case of contact.

- ▶ Never touch the components of the brake directly after the ride.
-

The drive force of the motor is shut off during the ride as soon as the rider no longer pedals. The drive system does not switch off when braking.

- ▶ In order to achieve optimum braking results, do not pedal while braking.

7.9.1 Using the brake lever

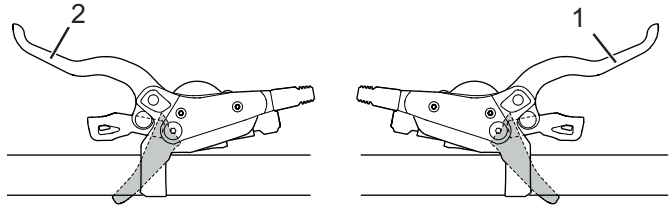

Figure 58: Front (2) and rear (1) brake lever – example: Shimano brake

- ▶ Pull the left *brake lever for the front wheel brake* and the *right lever for the rear wheel brake* until the desired speed is reached.

7.9.2 Using the back-pedal brake *Alternative*

- ✓ The best braking effect is achieved if the pedals are in the 3 o'clock and 9 o'clock position when braking. To bridge the free travel between the riding movement and the braking movement, it is recommendable to pedal a little beyond the 3 o'clock and 9 o'clock position before you pedal in the opposite direction to the *direction of travel* and start braking.
- ▶ Pedal in the opposite direction to the *direction of travel* until the desired speed has been reached.

7.10 Folding

Alternative

NOTICE

- ▶ Never crush or bend cables, electric cables or brake cables when folding.

7.10.1 Folding the folding bicycle

The bicycle is folded in eight steps.

- ▶ Switch off the *electric drive system*.
- ▶ Use the *kickstand*.
- ▶ Remove the *display*.
- ▶ Remove the *battery* if necessary.
- ▶ Fold the *pedal*.
- ▶ Fold the *stem*.
- ▶ Push in the *seat post*.
- ▶ Fold the *frame*.

7.10.1.1 Folding the pedal

- ▶ Push the pedal against the pedal crank with the foot.

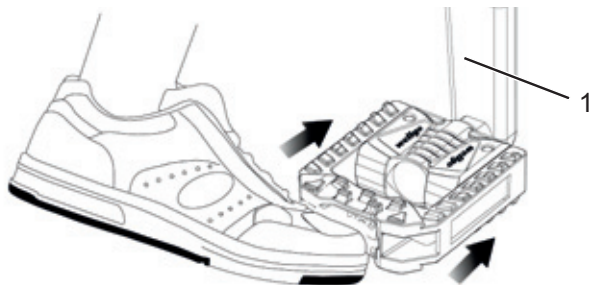

Figure 59: Pushing the pedal against the pedal crank (1)

- ▶ Fold the pedal against the pedal crank.

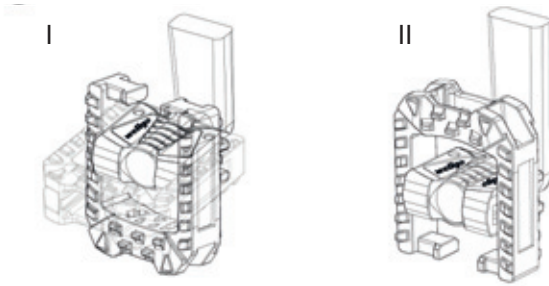

Figure 60: Folding the pedal up (I) or down (II)

7.10.2 Folding the stem, version I *Alternative*

- ▶ Open the *clamping lever on the stem quick release*.
- ▶ Pull the *locking lever on the stem* upwards and simultaneously pivot it 90° to the right or the left.
- ⇒ You feel the *handlebars* click into place.
- ▶ Push in the *handlebars*.
- ▶ Close the *clamping lever on the stem quick release*.



Figure 61: Opened clamping lever on the stem quick release (3) on the stem (2), version I, with locking lever on the stem (1)

7.10.2.1**Folding the stem, version II****Alternative**

- ▶ Open the *clamping lever on the stem quick release*.
- ▶ Push the *unlocking knob*.
- ▶ Pivot the *handlebars* 90° to the right or left.
- ⇒ You feel the *handlebars* click into place.
- ▶ Close the *clamping lever on the stem quick release*.

**Figure 62:**

Stem, version II with clamping lever on the stem quick release (1) and unlocking knob (2)

7.10.2.2**Pushing in the seat post**

- ▶ Open the *clamping lever for the quick release on the seat post*.
- ▶ Push in the *saddle* to the minimum position.
- ▶ Close the *clamping lever for the quick release on the seat post*.

7.10.2.3

Folding the frame

- ▶ Pivot the *frame locking lever* upwards.
- ⇒ The *frame clamping lever* can be opened freely.
- ▶ Open the *frame clamping lever*.
- ▶ Pivot in the frame as far as it will go.



Figure 63:

Frame, with closed frame clamping lever (1) and open frame locking lever (2)

7.10.3

Preparing the bicycle so that it is ready to ride again**Risk of fire and explosion due to faulty battery**

If the bicycle is not prepared correctly ready for use, this may result in the rider falling and sustaining serious injury.

- ▶ Only use bicycle when it is correctly prepared ready for use with the locking lever closed.



The specialist dealer will show the operator or rider how the bicycle is folded, how it is prepared, so that it is ready to ride again, and how the quick releases are used.

The bicycle is prepared so that it is ready to ride again in eight steps.

- ▶ *Switching off the electric drive system.*
- ▶ Use the *kickstand*.
- ▶ Fold out *the frame*.
- ▶ Adjust the *stem*.
- ▶ Adjust the *saddle*.
- ▶ Fold out *the pedal*.
- ▶ Insert the *battery*.
- ▶ Attach the *display*.

7.10.3.1

Folding out the frame

- ▶ Completely fold out the frame.
 - ▶ Close the *frame clamping lever*.
- ⇒ The *frame clamping lever* rests on the limit stop. The *frame locking lever* holds the *frame clamping lever*. The *frame clamping lever* is closed.

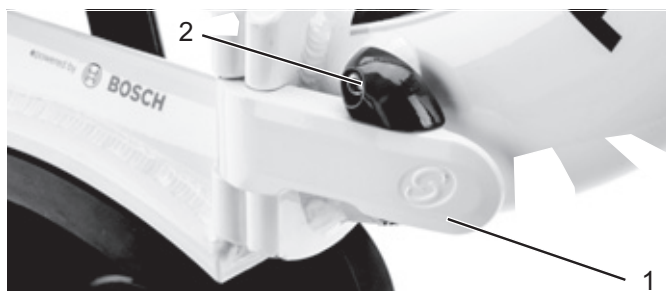

Figure 64: Frame, with closed frame clamping lever (1) and closed frame locking lever (2)

7.10.3.2 Folding out the pedal

- ▶ Push the pedal against the pedal crank with the foot from the front.

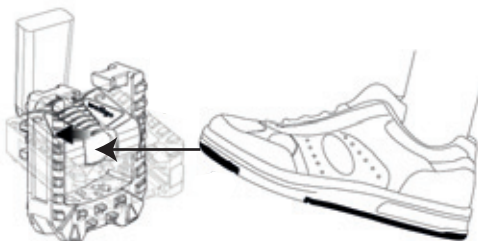

Figure 65: Pushing the pedal against the pedal crank (1)

- ▶ Use the foot to fold the pedal up or down.

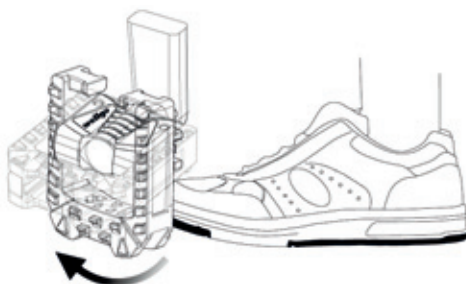

Figure 66: Folding up the pedal

8

Maintenance**Cleaning check list**

<input type="checkbox"/>	Clean pedals	after every ride
<input type="checkbox"/>	Clean suspension fork	after every ride
<input type="checkbox"/>	Cleaning the battery	once a month
<input type="checkbox"/>	Chain (mainly tarmacked road)	every 250–300 km
<input type="checkbox"/>	Basic cleaning and preservation of all components	at least every six months
<input type="checkbox"/>	Clean the charger	at least every six months
<input type="checkbox"/>	Clean and lubricate height-adjustable seat post	every six months

Maintenance check list

<input type="checkbox"/>	Check USB rubber cover position	before each ride
<input type="checkbox"/>	Check for tyre wear	once a week
<input type="checkbox"/>	Check for rim wear	once a week
<input type="checkbox"/>	Check the tyre pressure	once a week
<input type="checkbox"/>	Check brakes for wear	once a week
<input type="checkbox"/>	Check electrical cables and Bowden cables for damage and ensure they are fully functional	once a month
<input type="checkbox"/>	Check the chain tension	once a month
<input type="checkbox"/>	Check the tension of the spokes	every three months
<input type="checkbox"/>	Check the gear shift setting	every three months
<input type="checkbox"/>	Check the suspension fork for wear and ensure it is fully functional	every three months

<input type="checkbox"/>	Check steering	every three months
<input type="checkbox"/>	Check for wear on brake discs	at least every six months

Service check list

<input type="checkbox"/>	Functional check on the suspension fork	Every 50 hours
<input type="checkbox"/>	Suspension maintenance and dismantling	Every 100 hours or at least every year
<input type="checkbox"/>	Inspection by the specialist dealer	every six months
<input type="checkbox"/>	Inspection of the drive unit	15,000 km



Displaying next inspection date

The specialist dealer can set the display, so that it shows the inspection date based on the bicycle's mileage or the time since the last inspection.

The display will show you a text message with the word SERVICE for 4 seconds to indicate that an inspection is required each time you switch it on.

Ask your specialist dealer about this setting.

8.1

Cleaning and servicing



Crash and falling caused by unintentional activation

There is a risk of injury if the drive system is activated unintentionally.

- ▶ Remove the battery before cleaning.

The following servicing measures must be performed regularly. Servicing can be performed by the operator and rider. In case of any doubt, consult the specialist dealer.

8.1.1

After every ride

8.1.1.1

Clean suspension fork

- ▶ Remove dirt and deposits on the stanchions and deflector seals with a damp cloth.
- ▶ Check the stanchions for dents, scratches, staining or leaking oil.
- ▶ Check the air pressure.
- ▶ Lubricate the dust seals and stanchions.

8.1.1.2

Cleaning the pedals

- ▶ Clean with a brush and soapy water after riding through dirt or rain.
- ⇒ Service the pedals after cleaning.

8.1.2

Basic cleaning



CAUTION

Crash caused by brake failure

The braking effect may be unusually weak temporarily after cleaning, servicing or repairing the bicycle. Such damage may cause you to fall from the bicycle and injure yourself.

- ▶ Never apply care products or oil to the brake discs or brake linings, or the braking surfaces on the rims.
 - ▶ After cleaning, servicing or repair, carry out a few test brake applications.
-

NOTICE

Water may enter into the inside of the bearings if you use a steam jet. The lubricant inside is diluted, the friction increases and, as a result, the bearings are destroyed in the long term.

- ▶ Never clean the bicycle with a steam jet.
-

NOTICE

Greased parts, e.g. the seat post, the handlebars or the stem, may no longer be safely and reliably clamped.

- ▶ Never apply grease or oil to the clamping areas.
-
- ✓ Remove battery and display before basic cleaning.
-

8.1.2.1

Cleaning the frame

- ▶ Soak the dirt stains on the frame with dish-washing detergent if the dirt is thick and ingrained.
- ▶ After leaving it to soak for a time, remove the dirt and mud with a sponge, brush and toothbrush.
- ▶ Use a watering can or your hand to rinse the frame to finish off.
- ▶ Service the frame after cleaning.

8.1.2.2 **Cleaning the stem**

- ▶ Clean stem with a cloth and washing water.
- ▶ Service the stem after cleaning.

8.1.2.3 **Clean rear frame damper**

- ▶ Clean rear frame damper with a cloth and washing water.

8.1.2.4 **Cleaning the wheel**



Crash due to braking hard on rim

A rim can break and block the wheel if you brake hard. It may cause a crash with serious injuries.

- ▶ Check rim wear on a regular basis.
-
- ▶ Check the tyres, rims, spokes and spoke nipples for any damage when cleaning the wheel.
 - ▶ Use a sponge and a brush to clean the hub and spokes from the inside to the outside.
 - ▶ Clean the rim with a sponge.

8.1.2.5 **Cleaning the drive elements**

- ▶ Spray the cassette, the chain wheels and the front derailleur with a degreasing agent.
- ▶ Clean coarse dirt with a brush after soaking for a short time.
- ▶ Wash down all parts with dish-washing detergent and a toothbrush.
- ▶ Service the drive elements after cleaning.

8.1.2.6

Cleaning the chain

NOTICE

- ▶ Never use aggressive (acid-based) cleaners, rust removers or degreasers when cleaning the chain.
 - ▶ Do not use chain cleaning devices or chain cleaning baths.
-
- ▶ Slightly dampen a brush with dish-washing liquid. Brush both sides of the chain.
 - ▶ Dampen a cloth with dish-washing liquid. Place the cloth on the chain.
 - ▶ Hold with slight pressure while slowly turning the rear wheel, so the chain passes through the cloth.
 - ▶ If the chain is still dirty afterwards, clean it with WD40.
 - ▶ Service the chain after cleaning.

8.1.2.7

Cleaning the battery



Fire and explosion caused by penetration by water

The battery is only protected from simple spray water. Penetration by water can cause a short circuit. The battery may self-ignite and explode.

- ▶ Never clean the battery with a high-pressure water device, water jet or compressed air.
 - ▶ Never immerse the battery in water.
 - ▶ Never use cleaning agent.
 - ▶ Remove the battery from the bicycle before cleaning.
-
- ▶ Only clean the electrical connections of the battery with a dry cloth or brush.
 - ▶ Wipe off the decorative sides with a damp cloth.

8.1.2.8**Cleaning the drive unit**

NOTICE

If water enters into the drive unit, the unit will be permanently damaged.

- ▶ Never immerse the drive unit in water.
 - ▶ Never clean with a high-pressure water device, water jet or compressed air.
 - ▶ Never use cleaning agent.
-
- ▶ Carefully clean the drive unit with a damp, soft cloth.

8.1.2.9**Cleaning the display**

NOTICE

If water enters into the display, it will be permanently damaged.

- ▶ Never immerse the display in water.
 - ▶ Never clean with a high-pressure water device, water jet or compressed air.
 - ▶ Never use cleaning agent.
 - ▶ Remove the display from the bicycle before cleaning.
-
- ▶ Carefully clean the display with a damp, soft cloth.

8.1.2.10

Cleaning the brake



Brake failure due to water penetration

The brake seals are unable to withstand high pressures. Damaged brakes can fail and cause an accident with injury.

- ▶ Never clean the bicycle with a high-pressure water device or compressed air.
 - ▶ Take great care when using a hosepipe. Never point the water jet directly at the seal section.
-
- ▶ Clean brake and brake discs with a brush, water and dish-washing detergent.
 - ▶ Clean brake discs thoroughly with brake cleaner or spirit.

8.1.3 Servicing

8.1.3.1 Servicing the frame

- ▶ Dry frame after cleaning
- ▶ Spray with care oil Clean off the care oil again after a short time.

8.1.3.2 Servicing the stem

- ▶ Apply silicone or Teflon oil to the stem shaft tube and the quick release lever pivot point.
- ▶ If you have Speedlifter Twist, also apply oil to the unlocking bolt using the groove in the Speedlifter body.
- ▶ Apply a little acid-free lubricant grease between the stem quick release lever and the sliding piece to reduce the quick release lever operating force.

8.1.3.3 Servicing the fork

- ▶ Treat the dust seals with fork oil

8.1.3.4 Servicing the drive elements

- ▶ Spray the cassette, the chain wheels and the front derailleur with a degreasing agent.
- ▶ Clean coarse dirt with a brush after soaking for a short time.
- ▶ Wash down all parts with dish-washing detergent and a toothbrush.

8.1.3.5 Servicing the pedal

- ▶ Treat with spray oil after cleaning.

8.1.3.6

Servicing the chain

- ▶ Grease the chain thoroughly with chain oil after cleaning.

8.1.3.7

Servicing the drive elements

- ▶ Service Maintain front and rear derailleur articulated shafts and jockey wheels with Teflon spray.

8.2

Maintenance



CAUTION

Crash and falling caused by unintentional activation

There is a risk of injury if the drive system is activated unintentionally.

- ▶ Remove the battery before maintenance.
-

The following maintenance measures must be carried out regularly [[▷ Check list, page 141](#)]. They can be carried out by the operator and rider. In case of any doubt, consult the specialist dealer.

8.2.1

Wheel



WARNING

Crash due to braking hard on rim

A rim can break and block the wheel if you brake hard. It may cause a crash with serious injuries.

- ▶ Check rim wear on a regular basis.
-

NOTICE

If the pressure is too low in the tyre, the tyre does not achieve its load bearing capacity. The tyre is not stable and may come off the rim.

If the pressure in the tyre is too high, the tyre may burst.

- ▶ Check the tyre pressure against the specifications [[▷ Data sheet, page 1](#)]
 - ▶ *Adjust the tyre pressure* as necessary.
-
- ▶ Check the *tyre* wear.
 - ▶ Check the *tyre pressure*.
 - ▶ Check the *rims* for wear.
 - The rims of a rim brake with invisible wear indicator are worn as soon as the wear indicator becomes visible in the area of the rim joint.

- The rims with visible wear indicator are worn as soon as the black, all-round groove on the pad friction surface becomes invisible. We recommend that you also replace the *rims* with every second brake lining replacement.
- ▶ Check the tension of the spokes.

8.2.2

Brake system



Crash due to brake failure

Worn brake discs and brake linings and a lack of hydraulic fluid in the brake cable reduce the braking power. Such damage may cause you to fall from the bicycle and injure yourself.

- ▶ Check the brake disc, brake linings and the hydraulic brake system on a regular basis and replace if necessary.
-
- ▶ Replace the brake linings on the disc brake when the pad thickness has reached 0.5 mm.

8.2.3

Electrical cables and brake cables

- ▶ Check all visible electrical cables and cables for damage. If, for example, the sheathing is compressed, the bicycle will need to be removed from service until the cables have been replaced.
- ▶ Check all electrical cables and cables to make sure they are fully functional.

8.2.4

Gear shift

- ▶ Check the gear shift and the *shifter* or the *twist grip* setting and adjust it as necessary.

8.2.5

Stem

- ▶ The stem and quick release system should be inspected at regular intervals. The specialist dealer should adjust them if necessary.
- ▶ If the hexagon socket head screw is also loosened, the headset backlash also needs to be adjusted. Medium-strength thread locker, such as Loctite blue, then needs to be applied to the loosened screws and the screws tightened as per the instructions.
- ▶ Check for wear and signs of corrosion (maintain with an oily cloth) and for oil leaks.

8.2.6

Checking the chain and belt tension**NOTICE**

Excessive chain or belt tension increases wear.

If the chain or belt tension is too low, there is a risk that the *chain* or belt will slip off the *chain wheels*.

▶ Check the chain and belt tension once a month.

▶ Check the chain or belt tension in three or four positions, turning the crank a full revolution.

▶ If the *chain* or the belt can be pushed more than 2 cm, you need to have the *chain* or belt tensioned again by the specialist dealer.

▶ If the *chain* or the belt can only be pushed less than 1 cm, the *chain* or belt will need to be relieved of tension accordingly.

⇒ The ideal chain or belt tension has been achieved if the *chain* or the belt can be pushed a maximum of 2 cm in the middle between the pinion and the toothed wheel. The crank must also turn without resistance.



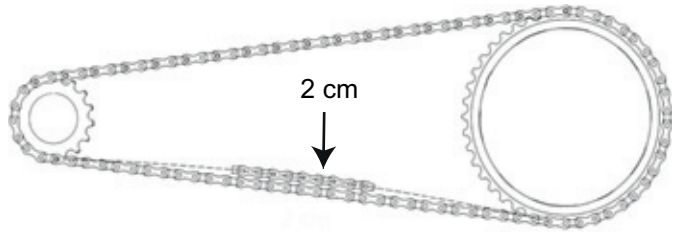

Figure 67: **Checking the chain and belt tension**



- ▶ If a hub gear is featured, the rear wheel must be pushed backwards or forwards to tighten the chain. This should be done by a specialist only.

8.2.7

USB port

NOTICE

Any moisture which enters through the USB port may trigger a short circuit in the *display*.

- ▶ Regularly check the position of the *cover on the USB port* and adjust it as necessary.
-

8.2.8

Suspension fork



- ▶ The specialist dealer will check the suspension fork function and the torques of attachment screws and nuts on the lower surfaces (steel: 10 Nm; alloy: 4 Nm). They will check the suspension fork for scratches, dents, cracks, stains, oil leaks or signs of wear or corrosion.

8.3

Service**Crash and falling caused by unintentional activation**

There is a risk of injury if the drive system is activated unintentionally.

- ▶ Remove the battery before the service.

**Crash caused by material fatigue**

If the service life of a component has expired, the component may suddenly fail. Such damage may cause you to fall from the bicycle and injure yourself.

- ▶ Have the specialist dealer carry out six-monthly basic cleaning of the bicycle, preferably at the same time as the required servicing work.

The specialist dealer must perform an inspection at least every six months. This is the only way to ensure that the bicycle remains safe and fully functional.



- ▶ The specialist dealer will inspect the bicycle for any signs of material fatigue during basic cleaning.
- ▶ The specialist dealer will check the software version of the drive system and update it. The electrical connections are checked, cleaned and preservative agent is applied. The electrical cables are inspected for damage.
- ▶ The specialist dealer will dismantle and clean the entire suspension fork interior and exterior. They will clean and lubricate the dust seals and slide bushings, check the torques and adjust the fork to the rider's preferred position. They will also replace the sliding collar if the clearance is too great (more than 1 mm on the fork bridge).



- ▶ The further servicing measures correspond to those which are recommended for a bicycle as per EN 4210. Particular attention is paid to the rim and brake wear. The spokes are re-tightened in accordance with the findings.

8.4**Adjusting and repairing**

**Crash and falling caused by unintentional activation**

There is a risk of injury if the drive system is activated unintentionally.

- ▶ Remove the battery before the service.
-

8.4.1**Use original parts and lubricants only**

The individual parts of the bicycle have been selected carefully and to matched to each other.

Only original parts and lubricants must be used for maintenance and repair.

The constantly updated lists of approved accessories and parts are available to specialist dealers.

8.4.2

Axle with quick release



CAUTION

Crash caused by unfastened quick release

A faulty or incorrectly installed quick release may become caught in the brake disc and block the wheel. This will cause a crash.

- ▶ Install the front wheel quick release lever on the opposite side to the brake disc.
-



CAUTION

Crash caused by faulty or incorrectly installed quick release

The brake disc becomes very hot during operation. Parts of the quick release may become damaged as a result. The quick release comes loose. This will result in a crash and injuries.

- ▶ The front wheel quick release lever and the brake disc must be situated on opposite sides.
-



CAUTION

Crash caused by incorrectly set clamping force

Excessively high clamping force will damage the quick release and cause it to lose its function.

Insufficient clamping force will cause a detrimental transmission of force. The suspension fork or the frame may break. This will result in a crash and injuries.

- ▶ Never fasten a quick release using a tool (e.g. hammer or pliers).
 - ▶ Only use the clamping lever with the specified set clamping force.
-

8.4.2.1

Checking the quick release

- ▶ Check the position and clamping force of the quick release lever. The quick release lever must be flush with the lower housing. You must be able to see a slight impression on the palm of your hand when you close the quick release lever.



Figure 68:

Adjusting the quick release clamping force

- ▶ Use a 4 mm hexagon socket spanner to adjust the clamping lever clamping force if required. Afterwards, check the quick release lever position and clamping force.

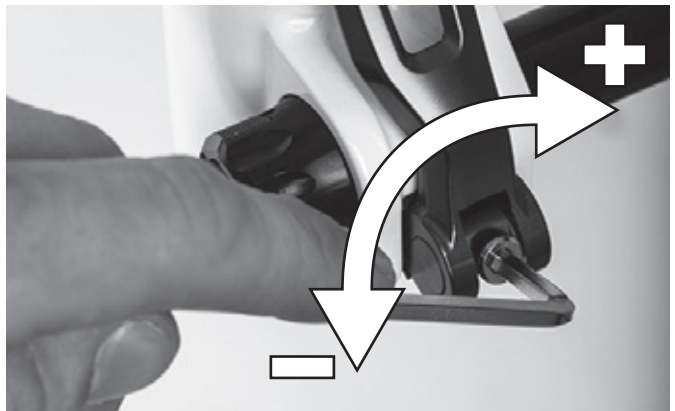

Figure 69:

Adjusting the quick release clamping force

8.4.3 Adjusting the tyre pressure

8.4.3.1 Dunlop valve

The tyre pressure cannot be measured on the simple Dunlop valve. The tyre pressure is therefore measured in the filling hose when pumping slowly with the bicycle pump.

✓ It is recommendable to use a bicycle pump with a pressure gauge. The operating instructions for the bicycle pump must be adhered to.

▶ Unscrew and remove the valve cap.

▶ Connect the bicycle pump.

▶ Pump up the tyre slowly and pay attention to the tyre pressure in the process.

⇒ The tyre pressure has been adjusted as per the data [[Data sheet, page 1](#)].

▶ If the tyre pressure is too high, unfasten the union nut, let off air and tighten the union nut again.

▶ Remove the bicycle pump.

▶ Screw the valve cap tight.

✓ Screw the rim nut gently against the rim with the tips of your fingers.

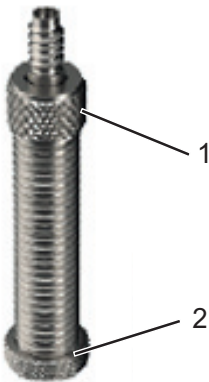

Figure 70:

Dunlop valve with union nut (1) and rim nut (2)

8.4.3.2

Presta valve

- ✓ It is recommendable to use a bicycle pump with a pressure gauge. The operating instructions for the bicycle pump must be adhered to.
- ▶ Unscrew and remove the valve cap.
- ▶ Open the knurled nut around four turns.
- ▶ Carefully apply the bicycle pump so that the valve insert is not bent.
- ▶ Pump up the tyre slowly and pay attention to the tyre pressure in the process.
- ⇒ The tyre pressure has been adjusted as per the data [[Data sheet, page 1](#)].
- ▶ Remove the bicycle pump.
- ▶ Tighten the knurled nut with your finger tips.
- ▶ Screw the valve cap tight.
- ▶ Screw the rim nut gently against the rim with the tips of your fingers.



Figure 71:

Presta valve with valve insert (1), knurled nut (2) and rim nut (3)

8.4.3.3

Schrader valve

- ✓ It is recommendable to use a bicycle pump with a pressure gauge. The operating instructions for the bicycle pump must be adhered to.
- ▶ Unscrew and remove the valve cap.
- ▶ Connect the bicycle pump.
- ▶ Pump up the tyre slowly and pay attention to the tyre pressure in the process.
- ⇒ The tyre pressure has been adjusted as per the data [[▷ Data sheet, page 1](#)].
- ▶ Remove the bicycle pump.
- ▶ Screw the valve cap tight.
- ▶ Screw the rim nut gently against the rim with the tips of your fingers.



Figure 72:

Schrader valve with rim nut (1)

8.4.4

Adjusting the gear shift

If the gears cannot be selected cleanly, the setting for the shift cable tension will need to be adjusted.

- ▶ Carefully pull the *adjusting sleeve* away from the shifter housing, turning it in the process.
- ▶ Check the function of the gear shift after each adjustment.



If the gear shift cannot be adjusted this way, the specialist dealer will need to check the gear shift assembly.

8.4.4.1

Cable-operated gear shift, single-cable *Alternative*

- ▶ For a smooth gear shift, adjust the adjusting sleeves on the shifter housing.

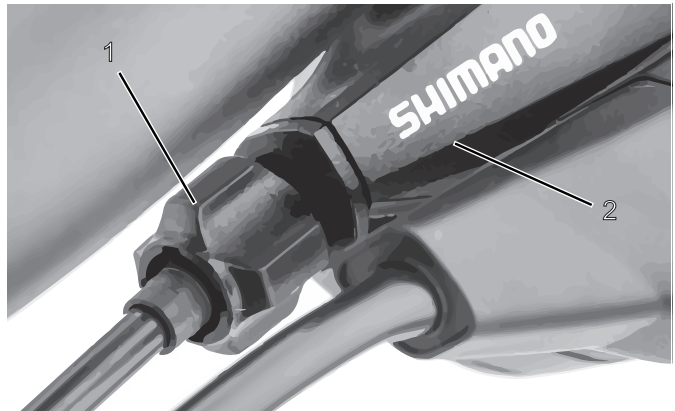

Figure 73:

Adjusting sleeve (1) for the single-cable cable-operated gear shift with shifter housing (2), example

8.4.4.2

Cable-operated gear shift, dual-cable
Alternative

- ▶ For a smooth gear shift, set the adjusting sleeves underneath the chain stay on the frame.
- ▶ The shift cable has play of approximately 1 mm when it is pulled out gently.

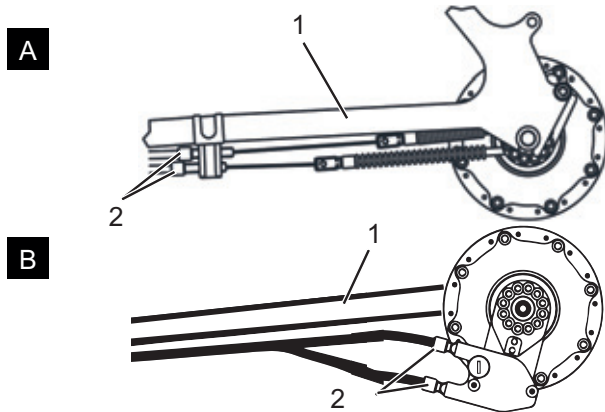

Figure 74: Adjusting sleeves (2) on two alternative versions (A and B) of a dual-cable cable-operated gear shift on the chain stay (1)

8.4.4.3

**Cable-operated twist grip, dual-cable
Alternative**

- ▶ For a smooth gear shift, set the adjusting sleeves on the shifter housing.
- ⇒ There is noticeable play of around 2 - 5 mm (1/2 gear) when twisting the twist grip.

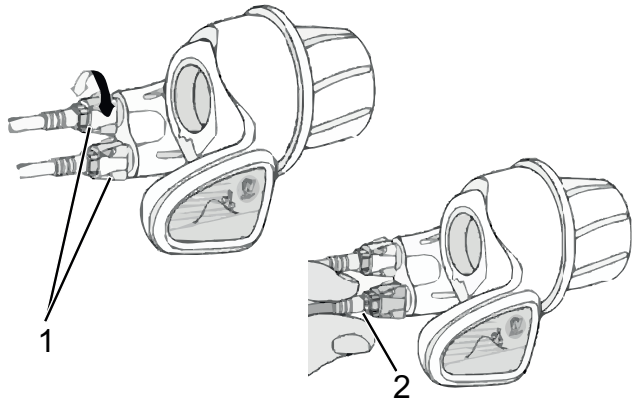

Figure 75:

Twist grip with adjusting sleeves (1) and play of the gear shift (2)

8.4.5 Offsetting brake lining wear

8.4.5.1 Hydraulically operated rim brake *Alternative*

The *setting bolt* on the *brake lever* of the hydraulic rim brake is used to offset the brake lining wear. If the profile of the brake linings has a remaining depth of just 1 mm, the brake linings need to be replaced.

- ▶ In order to reduce the free travel and offset the brake lining wear, screw the *setting bolt* in.
 - ▶ In order to increase the free travel, screw the *setting bolt* out.
- ⇒ With the optimum setting the action point, i.e. the point at which the brake takes effect, is reached after 10 mm of empty travel.



Figure 76: Brake lever (1) of the hydraulically operated rim brake with setting bolt (2)

8.4.5.2 **Hydraulically operated disc brake** *Alternative*

The brake pad wear on the disc brake does not require readjustment.

8.4.6 **Replacing the lighting**

Alternatively a 3 watt or 1.5 watt lighting system can be installed.

- ▶ Only use components of the respective power class for replacement.

8.4.7 **Setting the headlight**

- ▶ The *headlight* must be set, so that its light beam meets the road 10 m in front of the bicycle.

8.4.8 **Repair by the specialist dealer**



Special knowledge and tools are required for many repairs. Only a specialist dealer may carry out the following repairs, for instance:

- Replacing *tyres* and rims,
- Replacing brake pads and brake linings
- Replacing and tensioning the *chain*.

8.5

Cargo 1000 accessories

Special accessories are recommended to secure the load of the Cargo 1000 and ensure safe use of the usable surface. The permitted payload is reduced in proportion to the mass of the accessories used.

<i>Description</i>	<i>Article number</i>
Transport box	455-00068
Side walls	455-00069
Child seat	455-00073

Table 30:

Accessories

* The operating manuals for the accessories are enclosed with these operating instructions.

8.5.1

Child seat



Crash due to incorrect child seat

Neither the pannier rack or the bicycle down tube are suitable for child seats and may break. Such an incorrect position may cause a crash with serious injuries for the rider and the child.

- ▶ Never attach a child seat to the saddle, handlebars or down tube.



Crash caused by improper handling

When using child seats, the riding properties and the stability of the bicycle change considerably. This can cause a loss of control, a crash and injuries.

- ▶ You should practice how to use the child seat safely and reliably before using the bicycle in public spaces.



Risk of crushing due to exposed springs

The child may crush his/her fingers on exposed springs or open mechanical parts of the saddle or the seat post.

- ▶ Never install saddles with exposed springs if a child seat is being used.
- ▶ Never install seat posts with suspension with open mechanical parts or exposed springs if a child seat is being used.

NOTICE

- ▶ Observe the legal regulations on the use of child seats.
- ▶ Observe the operating and safety notes for the child seat system.
- ▶ Never exceed the total weight of the bicycle.



The specialist dealer will advise you on the choice of right child seat system for the child and the bicycle.

The specialist dealer must mount the child seat the first time to ensure that it is safely fitted.

When installing a child seat, the specialist dealer makes sure that the seat and the fastening mechanism for the seat are suitable for the bicycle and that all components are installed and firmly fastened. They will also ensure that shift cables, brake cables, hydraulic and electrical cables are adjusted as necessary, the rider's freedom of movement is not restricted and the bicycle's permitted total weight is not exceeded.

The specialist dealer will provide instruction on how to handle the bicycle and the child seat.

8.5.2

Bicycle trailer



Crash caused by brake failure

The brake may not work sufficiently if there is an excessive trailer load. The long braking distance can cause a crash or an accident and injuries.

▶ Never exceed the specified trailer load.



▶ The operating and safety notes for the trailer system must be observed.

▶ The legal regulations on use of bicycle trailers must be observed.

▶ Only use type approved coupling systems.

A bicycle which is approved for towing a trailer is equipped with the respective information sign. Only bicycle trailers with a support load and total mass which do not exceed the permitted values, must be used.

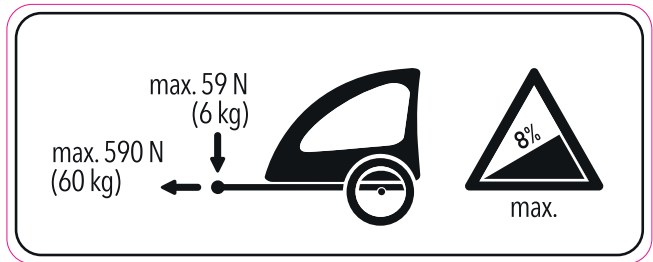

Figure 77:

Trailer sign



The specialist dealer will advise you on the choice of the right trailer system for the bicycle.

The specialist dealer must install the trailer the first time to ensure that it is safely fitted.

8.5.3

Pannier rack



The specialist dealer will advise on choosing a suitable pannier rack.

The specialist dealer must mount the pannier rack the first time to ensure that it is safely fitted.

When installing a pannier rack, the specialist dealer makes sure that the rack and the fastening mechanism for the rack are suitable for the bicycle and that all components are installed and firmly fastened. They will also ensure that shift cables, brake cables, hydraulic and electrical cables are adjusted as necessary, the rider's freedom of movement is not restricted and the permitted total weight of the bicycle is not exceeded.

The specialist dealer will provide instruction on how to handle the bicycle and the pannier rack.

8.5.4

First aid



Fire and explosion due to faulty batteries

The safety electronics on damaged or faulty batteries may fail. The residual voltage can cause a short circuit. The batteries may self-ignite and explode.

- ▶ Batteries with external damage must be removed from service immediately.
 - ▶ Never allow damaged batteries to come into contact with water.
 - ▶ If a battery is dropped or struck but shows no signs of external damage, remove the battery from service and observe it for at least 24 hours.
 - ▶ Faulty batteries are hazardous goods. Dispose of faulty batteries properly and as quickly as possible.
 - ▶ Store in a dry place until disposal. Never store in the vicinity of flammable substances.
 - ▶ Never open or repair the battery.
-

The components of the drive system are checked constantly and automatically. If an error is detected, the respective error code appears on the *display*. The drive may be shut off automatically, depending on the type of error.

8.5.5**The electric drive system or display do not start up**

If the display and/or the drive system do not start up, proceed as follows:

- ▶ Check whether the battery is switched on. If not, start the battery.
- ⇒ Contact specialist dealer if the charge status indicator LEDs do not light up.
- ▶ If the LEDs of the charge status indicator light up, but the drive system does not start up, remove the battery.
- ▶ Insert the battery.
- ▶ Start the drive system.
- ▶ If the drive system does not start up, remove the battery.
- ▶ Clean all the contacts with a soft cloth.
- ▶ Insert the battery.
- ▶ Start the drive system.
- ▶ If the drive system does not start up, remove the battery.
- ▶ Fully charge the battery.
- ▶ Insert the battery.
- ▶ Start the drive system.
- ▶ If the drive system does not start up, remove the display.
- ▶ Fasten the display.
- ▶ Start the drive system.
- ▶ Contact your specialist dealer if the drive system does not start up.

8.5.5.1

System messages

If an error message is displayed, run through the following actions:

- ▶ Make a note of the system message.
- ▶ Shut off and re-start the drive system.
- ▶ If the system message is still displayed, remove and then re-insert the battery.
- ▶ Re-start the drive system.
- ▶ If the system message is still displayed, contact your specialist dealer.

8.5.5.2

Special system messages

- ▶ Make a note of the system message. You will find the complete system error list in the appendix.

Code	Remedy
410, 418	▶ Check whether buttons are jammed because dirt has got into them, for example. Clean the buttons if necessary.
430	▶ Recharge internal display battery.
502	<ul style="list-style-type: none"> ▶ Check the light and its cabling. ▶ Re-start the system. ▶ If the problem persists, contact your specialist dealer.
530, 591, 655	<ul style="list-style-type: none"> ▶ Turn off the drive system. ▶ Remove the battery. ▶ Insert the battery again. ▶ Re-start the system. ▶ If the problem persists, contact your specialist dealer.

Table 31:

Error eradication using the code

Code	Remedy
540, 605	<ul style="list-style-type: none"> ▶ The bicycle is outside the permitted temperature range. ▶ Switch the bicycle off to cool the drive unit down or warm it up to the permitted temperature range. ▶ Re-start the system. ▶ If the problem persists, contact your specialist dealer.
550	<ul style="list-style-type: none"> ▶ Remove the electrical load. ▶ Re-start the system. ▶ If the problem persists, contact your specialist dealer.
592	<ul style="list-style-type: none"> ▶ Insert a compatible display. ▶ Re-start the system. ▶ If the problem persists, contact your specialist dealer.
602	<ul style="list-style-type: none"> ▶ Disconnect the charger from the battery. ▶ Re-start the system. ▶ Plug the charger into the battery. ▶ If the problem persists, contact your specialist dealer.
605	<ul style="list-style-type: none"> ▶ Disconnect the charger from the battery. ▶ Let the battery cool down. ▶ If the problem persists, contact your specialist dealer.
620	<ul style="list-style-type: none"> ▶ Replace the charger. ▶ If the problem persists, contact your specialist dealer.
656	<ul style="list-style-type: none"> ▶ Contact your specialist dealer to install a software update.
7xx	<ul style="list-style-type: none"> ▶ Please observe the manufacturer's operating instructions.
No screen display	<ul style="list-style-type: none"> ▶ Re-start your drive system by switching it on and off.

Table 31:

Error eradication using the code

- ▶ If the system message is still displayed, contact your specialist dealer.

9

Recycling and disposal



Risk of fire and explosion

The safety electronics on damaged or faulty batteries may fail. The residual voltage can cause a short circuit. The batteries may self-ignite and explode.

- ▶ Remove batteries with external damage from service immediately and never charge them.
- ▶ If the battery becomes deformed or begins to smoke, keep at a safe distance, disconnect the power supply at the socket, and notify the fire service immediately.
- ▶ Never extinguish damaged batteries with water or allow them to come into contact with water.
- ▶ Faulty batteries are hazardous goods. Dispose of faulty batteries properly and as quickly as possible.
- ▶ Store in a dry place until disposal. Never store in the vicinity of flammable substances.
- ▶ Never open or repair the battery.



Chemical burns to the skin and eyes

Liquids and vapours may leak from damaged or faulty batteries. They can irritate the airways and cause burns.

- ▶ Avoid contact with leaked liquids.
 - ▶ Immediately consult a doctor in case of contact with the eyes or any discomfort.
 - ▶ In case of contact with the skin, rinse off immediately with water.
 - ▶ Ventilate the room well.
-



This device is marked according to the European Directive 2012/19/EU on waste electrical and electronic equipment – WEEE. The directive provides the framework for the return and recycling of used devices across the EU.



The bicycle, battery, display and charger are recyclable materials. You must dispose of and recycle them separately from the domestic waste in compliance with applicable statutory regulations.

Separate collection and recycling saves reserves of raw materials and ensures that all the regulations for protection of health and the environment are adhered to when recycling the product and/or the battery.

- ▶ Never dismantle the bicycle, battery or charger for disposal.
- ▶ The bicycle, display, the unopened and undamaged battery and the charger can be returned to any specialist dealer free of charge. Depending on the region, further disposal options may be available.
- ▶ Store the individual parts of the decommissioned bicycle in a dry place, free from frost, where they are protected from direct sunlight.

10 Appendix

10.1 System messages

Code	Cause	Remedy
410	One or more display buttons are blocked	▶ Check whether buttons are jammed because dirt has got into them, for example. Clean the buttons if necessary.
414	Control panel connection problem	▶ Have ports and connections checked
418	One or more buttons on the control panel are blocked.	▶ Check whether buttons are jammed because dirt has got into them, for example. Clean the buttons if necessary.
419	Configuration error	<ul style="list-style-type: none"> ▶ Re-start the system. ▶ If the problem persists, contact your specialist dealer.
422	Drive unit connection problem	▶ Have ports and connections checked
423	Battery connection problem	▶ Have ports and connections checked
424	Communication error with components communicating with one another	▶ Have ports and connections checked
426	Internal time-out error	<ul style="list-style-type: none"> ▶ Re-start the system. ▶ If the problem persists, contact your specialist dealer. <p>It is not possible to display or adjust the tyre size in the basic settings menu in this error status.</p>
430	Internal display battery empty	▶ Recharge internal display battery (in its bracket or using USB port)
431	Software version error	<ul style="list-style-type: none"> ▶ Re-start the system. ▶ If the problem persists, contact your specialist dealer.

Table 32: List of system messages

Code	Cause	Remedy
440	Internal drive unit error	<ul style="list-style-type: none"> ▶ Re-start the system. ▶ If the problem persists, contact your specialist dealer.
450	Internal software error	<ul style="list-style-type: none"> ▶ Re-start the system. ▶ If the problem persists, contact your specialist dealer.
460	Error in USB port	<ul style="list-style-type: none"> ▶ Re-start the system. ▶ If the problem persists, contact your specialist dealer.
490	Internal display error	<ul style="list-style-type: none"> ▶ Have display checked
500	Internal drive unit error	<ul style="list-style-type: none"> ▶ Re-start the system. ▶ If the problem persists, contact your specialist dealer.
502	Error in the bicycle lighting	<ul style="list-style-type: none"> ▶ Check the light and its cabling. ▶ Re-start the system. ▶ If the problem persists, contact your specialist dealer.
503	Speed sensor error	<ul style="list-style-type: none"> ▶ Re-start the system. ▶ If the problem persists, contact your specialist dealer.
510	Internal sensor error	<ul style="list-style-type: none"> ▶ Re-start the system. ▶ If the problem persists, contact your specialist dealer.
511	Internal drive unit error	<ul style="list-style-type: none"> ▶ Re-start the system. ▶ If the problem persists, contact your specialist dealer.
530	Battery error	<ul style="list-style-type: none"> ▶ Turn off the drive system. ▶ Remove the battery. ▶ Insert the battery again. ▶ Re-start the system. ▶ If the problem persists, contact your specialist dealer.
531	Configuration error	<ul style="list-style-type: none"> ▶ Re-start the system. ▶ If the problem persists, contact your specialist dealer.

Table 32: List of system messages

Code	Cause	Remedy
540	Temperature error	<ul style="list-style-type: none"> ▶ The bicycle is outside the permitted temperature range. ▶ Switch the bicycle off to cool the drive unit down or warm it up to the permitted temperature range. ▶ Re-start the system. ▶ If the problem persists, contact your specialist dealer.
550	An inadmissible electrical load has been detected	<ul style="list-style-type: none"> ▶ Remove the electrical load. ▶ Re-start the system. ▶ If the problem persists, contact your specialist dealer.
580	Software version error	<ul style="list-style-type: none"> ▶ Re-start the system. ▶ If the problem persists, contact your specialist dealer.
591	Authentication error	<ul style="list-style-type: none"> ▶ Turn off the drive system. ▶ Remove the battery. ▶ Insert the battery again. ▶ Re-start the system. ▶ If the problem persists, contact your specialist dealer.
592	Incompatible component	<ul style="list-style-type: none"> ▶ Insert a compatible display. ▶ Re-start the system. ▶ If the problem persists, contact your specialist dealer.
593	Configuration error	<ul style="list-style-type: none"> ▶ Re-start the system. ▶ If the problem persists, contact your specialist dealer.
595, 596	Communication error	<ul style="list-style-type: none"> ▶ Check the cabling to the gears. ▶ Re-start the system. ▶ If the problem persists, contact your specialist dealer.
602	Internal battery error during the charging process	<ul style="list-style-type: none"> ▶ Disconnect the charger from the battery. ▶ Re-start the system. ▶ Plug the charger into the battery. ▶ If the problem persists, contact your specialist dealer.

Table 32: List of system messages

Code	Cause	Remedy
602	Internal battery error	<ul style="list-style-type: none"> ▶ Re-start the system. ▶ If the problem persists, contact your specialist dealer.
603	Internal battery error	<ul style="list-style-type: none"> ▶ Re-start the system. ▶ If the problem persists, contact your specialist dealer.
605	Battery temperature error	<ul style="list-style-type: none"> ▶ The bicycle is outside the permitted temperature range. ▶ Switch the system off to cool the drive unit down or warm it up to the permitted temperature range. ▶ Re-start the system. ▶ If the problem persists, contact your specialist dealer.
605	Battery temperature error during the charging process	<ul style="list-style-type: none"> ▶ Disconnect the charger from the battery. ▶ Let the battery cool down. ▶ If the problem persists, contact your specialist dealer.
606	External battery error	<ul style="list-style-type: none"> ▶ Check the cabling. ▶ Re-start the system. ▶ If the problem persists, contact your specialist dealer.
610	Battery voltage error	<ul style="list-style-type: none"> ▶ Re-start the system. ▶ If the problem persists, contact your specialist dealer.
620	Charger error	<ul style="list-style-type: none"> ▶ Replace the charger. ▶ If the problem persists, contact your specialist dealer.
640	Internal battery error	<ul style="list-style-type: none"> ▶ Re-start the system. ▶ If the problem persists, contact your specialist dealer.
655	Multiple battery error	<ul style="list-style-type: none"> ▶ Turn off the system. ▶ Remove the battery. ▶ Insert the battery again. ▶ Re-start the system. ▶ If the problem persists, contact your specialist dealer.

Table 32: List of system messages

Code	Cause	Remedy
656	Software version error	▶ Contact your specialist dealer to install a software update.
7xx	Gear error	▶ Please observe the manufacturer's operating instructions.
No screen display	Internal display error	▶ Re-start your drive system by switching it on and off.

Table 32: List of system messages

10.2

EC declaration of conformity

Translation of the original EC declaration of conformity

The manufacturer:

HERCULES GMBH
Longericher Str. 2
50739 Köln, Germany

hereby declares that the electrically power assisted cycles of types:

19-P-0001, 19-P-0002, 19-P-0003, 19-P-0004, 19-P-0005, 19-P-0006, 19-P-0007, 19-Q-0003,
19-Q-0004, 19-Q-0006, 19-Q-0007, 19-Q-0008, 19-Q-0010, 19-Q-0011, 19-Q-0012, 19-Q-0019,
19-Q-0020, 19-Q-0021, 19-Q-0022, 19-Q-0024, 19-Q-0025, 19-Q-0026, 19-Q-0027, 19-Q-0030,
19-Q-0031, 19-Q-0032, 19-Q-0033, 19-Q-0034, 19-Q-0035, 19-Q-0036, 19-Q-0037, 19-Q-0038,
19-Q-0040, 19-Q-0041, 19-Q-0042, 19-Q-0043, 19-Q-0044, 19-Q-0046, 18-Q-0047, 19-Q-0053,
19-Q-0054, 19-Q-0055, 19-Q-0056, 19-Q-0057, 19-Q-0058, 19-Q-0059, 19-Q-0060, 19-Q-0061,
19-Q-0062, 19-Q-0063, 19-Q-0064, 19-Q-0065, 19-Q-0066, 19-Q-0067, 19-Q-0068, 19-Q-0069,
19-Q-0070, 19-Q-0071, 19-Q-0080, 19-Q-0081, 19-Q-0098, 19-Q-0099, 19-Q-0100, 19-Q-0101,
19-Q-0102, 19-Q-0103, 19, X-0082, 19-Y-0003, 19-Y-0004, 19-Y-0005, 19-Y-0006, 19-Y-0007,
19-Y-0008, 19-Y-0009

year of manufacture 2018 and year of manufacture 2019,

comply with all applicable requirements of **Machinery Directive 2006/42/EC**. Furthermore, the electrically power assisted cycles comply with all applicable basic requirements of **Electromagnetic Compatibility Directive 2014/30/EU**.

The following standards were applied: **ISO 12100:2010** Safety of machinery – General principles of design – Risk assessment and reduction; **EN 15194:2015** Cycles – Electrically power assisted cycles – EPAC bicycles; **ISO 4210-2:2015**, Cycles – Safety requirements for bicycles – Part 2: Requirements for city and trekking, young adult, mountain and racing bicycles; **EN 11243:2016**, Cycles – Luggage carriers for bicycles – Requirements and test methods.

Ms. Janine Otto (Technical Editor, tekomp), c/o HERCULES GmbH, Longericher Str. 2, 50739 Köln, Germany, is authorised to compile the technical documentation.



Cologne, 29.08.2018

Place, date and signature

Georg Honkomp

-Managing Director-

10.3 Parts list

Model	Cargo 500
Type no.	
Motor	Bosch PERFORMANCE mid-motor, 250 Watt, with free-wheeling
Display	Bosch INTUVIA
Battery	500 Wh
Battery type	Standard
Frame	Aluminium 7005, FW 20"/RW 26", with carrying surface
Fork	Spinner 300, tapered, 80 mm deflection
Gears	NuVinci 360, infinitely adjustable
Shifter	NuVinci, twist grip
Pedal crank	Aluminium GEN2
Chain/belt	KMC chain
Brake	Formula CR3, hydraulic disc brake
Brake lever	Formula for hydraulic disc brake
Tyre	Schwalbe BIG APPLE, FW: 55-406, KGuard/RW: 60-559, RaceGuard
Front wheel hub	Shimano M756, disc
Rear wheel hub	NuVinci N360, infinitely adjustable, with free-wheeling
Spokes	Black
Handlebars	Riser, aluminium
Stem/handlebars shaft	Aluminium, adjustable, toolless
Handles	Ergon
Saddle	Selle Royal LookIn Relaxed
Seat post	Patent, aluminium
Headlight	Busch & Müller Lumotec EYC IQ, up to 50 lux
Rear light	Busch & Müller Toplight View
Pannier rack	I-Rack, aluminium
Protective plate	SKS, plastic
Locks	Abus Shield 5650 LH-3
Stand	System's own two-leg stand
Charger (included in supply)	Bosch 4A charger

Table 33: Parts list for Cargo 500

Model	E-Imperial 180 S 9
Type no.	19-P-0005, 19-P-0006
Motor	Bosch PERFORMANCE mid-motor, 250 Watt, with free-wheeling
Display	Bosch INTUVIA
Battery	500 Wh
Battery type	Men's and trapezoidal: Standard/wave: Pannier rack
Frame	Aluminium 7005, tour, reinforced
Fork	SR Suntour NEX-E25, hydraulic lockout, tapered, with reinforced spring
Gears	Shimano Deore, 9-gear
Shifter	Shimano Alivio, Rapidfire Plus
Pedal crank	Aluminium GEN2
Chain/belt	KMC
Brake	Magura MT400, hydraulic disc brake
Brake lever	Shimano MT400, for hydraulic disc brake
Tyre	Schwalbe MARATHON PLUS 47-622, SmartGuard
Front wheel hub	Shimano, centre lock, with quick release
Rear wheel hub	Shimano, centre lock, with quick release
Spokes	Stainless steel, reinforced, black
Handlebars	Humpert Ergotec Low Riser, Safety Level 6
Stem/handlebars shaft	Humpert Ergotec Swell-R70, Ahead, adjustable
Handles	Ergon
Saddle	Selle Royal Viaggio
Seat post	Humpert Ergotec Skalar Patent, aluminium, Safety Level 6
Headlight	Herrmans H-Black MR8; up to 50 lux/180 lumens
Rear light	Busch & Müller 2C, pannier rack LED rear light
Pannier rack	I-Rack, aluminium, welded into position/wave: with battery mount
Protective plate	SKS, plastic
Locks	AXA Victory, with simultaneous locking battery lock
Stand	Pletscher Comp Flex 40
Charger (included in supply)	Bosch 4A charger

Table 34: **E-Imperial 180 S 9 parts list**

Model	E-Imperial 180 S F8
Type no.	19-P-0001, 19-P-0002
Motor	Bosch PERFORMANCE mid-motor, 250 Watt, with free-wheeling
Display	Bosch INTUVIA
Battery	500 Wh
Battery type	Men's and trapezoidal: Standard/wave: Pannier rack
Frame	Aluminium 7005, tour, reinforced
Fork	SR Suntour NEX-E25, hydraulic lockout, tapered, with reinforced spring
Gears	Shimano Alfine, 8-gear
Shifter	Shimano Alfine, Rapidfire Plus
Pedal crank	Aluminium GEN2
Chain/belt	KMC
Brake	Magura HS-22, hydraulic rim brake
Brake lever	Magura HS-22
Tyre	Schwalbe MARATHON PLUS 47-622, SmartGuard
Front wheel hub	Shimano with quick release
Rear wheel hub	Shimano Alfine, 8-gear, with free-wheeling
Spokes	Stainless steel, reinforced, black
Handlebars	Humpert Ergotec Low Riser, Safety Level 6
Stem/handlebars shaft	Humpert Ergotec Swell-R70, Ahead, adjustable
Handles	Ergon
Saddle	Selle Royal Viaggio
Seat post	Humpert Ergotec Skalar Patent, aluminium, Safety Level 6
Headlight	Herrmans H-Black MR8; up to 50 lux/180 lumens
Rear light	Busch & Müller 2C, pannier rack LED rear light
Pannier rack	I-Rack, aluminium, welded into position/wave: with battery mount
Protective plate	SKS, plastic
Locks	AXA Victory, with simultaneous locking battery lock
Stand	Pletscher Comp Flex 40
Charger (included in supply)	Bosch 4A charger

Table 35: E-Imperial 180 S F8 parts list

Model	E-Imperial 180 S R8
Type no.	19-P-0003, 19-P-0004
Motor	Bosch ACTIVE PLUS mid-motor, 250 Watt, with backpedal
Display	Bosch INTUVIA
Battery	500 Wh
Battery type	Men's and trapezoidal: Standard/wave: Pannier rack
Frame	Aluminium 7005, tour, reinforced
Fork	SR Suntour NEX-E25, hydraulic lockout, tapered, with reinforced spring
Gears	Shimano Nexus, 8-gear
Shifter	Shimano Nexus, twist grip
Pedal crank	Aluminium GEN3
Chain/belt	KMC
Brake	Magura HS-22, hydraulic rim brake
Brake lever	Magura HS-22
Tyre	Schwalbe MARATHON PLUS 47-622, SmartGuard
Front wheel hub	Shimano with quick release
Rear wheel hub	Shimano Nexus, 8-gear, with back-pedal brake
Spokes	Stainless steel, reinforced, black
Handlebars	Humpert Ergotec Low Riser, Safety Level 6
Stem/handlebars shaft	Humpert Ergotec Swell-R70, Ahead, adjustable
Handles	Ergon
Saddle	Selle Royal Viaggio
Seat post	Humpert Ergotec Skalar Patent, aluminium, Safety Level 6
Headlight	Herrmans H-Black MR8; up to 50 lux/180 lumens
Rear light	Busch & Müller 2C, pannier rack LED rear light
Pannier rack	I-Rack, aluminium, welded into position/wave: with battery mount
Protective plate	SKS, plastic
Locks	AXA Victory, with simultaneous locking battery lock
Stand	Pletscher Comp Flex 40
Charger (included in supply)	Bosch 4A charger

Table 36: **E-Imperial 180 S R8 parts list**

Model	E-Joy F7
Type no.	19-Q-0080
Motor	Bosch ACTIVE mid-motor, 250 Watt, with free-wheeling
Display	Bosch INTUVIA
Battery	400 Wh
Battery type	Pannier rack
Frame	Aluminium 7005, tour with intelligent seat position
Fork	SR Suntour NEX-E25, with adjustable spring hardness
Gears	Shimano Nexus, 7-gear
Shifter	Shimano Nexus, twist grip
Pedal crank	Aluminium GEN3
Chain/belt	KMC
Brake	Magura HS-22, hydraulic rim brake
Brake lever	Magura HS-22
Tyre	Schwalbe MARATHON PLUS 40-622, SmartGuard
Front wheel hub	Shimano with quick release
Rear wheel hub	Shimano Nexus, 7-gear, with free-wheeling
Spokes	Stainless steel, black
Handlebars	Touring, aluminium
Stem/handlebars shaft	Aluminium, adjustable without tools
Handles	Ergo, with integrated clamping
Saddle	Selle Royal LookIn Relaxed
Seat post	Patent, aluminium for ISP
Headlight	Herrmans H-Black MR4; up to 40 lux/100 lumens
Rear light	Busch & Müller 2C, pannier rack LED rear light
Pannier rack	I-Rack, aluminium with battery mount, welded on
Protective plate	SKS, plastic
Locks	AXA Solid Plus, with simultaneous locking battery lock
Stand	Pletscher Comp Flex 40
Charger (included in supply)	Bosch 2A compact charger

Table 37: E-Joy F7 parts list

Model	E-Joy R7
Type no.	19-Q-0081
Motor	Bosch ACTIVE mid-motor, 250 Watt, with backpedal
Display	Bosch INTUVIA
Battery	400 Wh
Battery type	Pannier rack
Frame	Aluminium 7005, tour with intelligent seat position
Fork	SR Suntour NEX-E25, with adjustable spring hardness
Gears	Shimano Nexus, 7-gear
Shifter	Shimano Nexus, twist grip
Pedal crank	Aluminium GEN3
Chain/belt	KMC
Brake	Magura HS-22, hydraulic rim brake
Brake lever	Magura HS-22
Tyre	Schwalbe MARATHON PLUS 40-622, SmartGuard
Front wheel hub	Shimano with quick release
Rear wheel hub	Shimano Nexus, 7-gear, with back-pedal brake
Spokes	Stainless steel, black
Handlebars	Touring, aluminium
Stem/handlebars shaft	Aluminium, adjustable without tools
Handles	Ergo, with integrated clamping
Saddle	Selle Royal LookIn Relaxed
Seat post	Patent, aluminium for ISP
Headlight	Herrmans H-Black MR4; up to 40 lux/100 lumens
Rear light	Busch & Müller 2C, pannier rack LED rear light
Pannier rack	I-Rack, aluminium with battery mount, welded on
Protective plate	SKS, plastic
Locks	AXA Solid Plus, with simultaneous locking battery lock
Stand	Pletscher Comp Flex 40
Charger (included in supply)	Bosch 2A compact charger

Table 38: E-Joy R7 parts list

Model	Futura Comp I
Type no.	19-Q-0061, 19-Q-0062, 19-Q-0063
Motor	Bosch PERFORMANCE CX mid-motor, 250 Watt, with free-wheeling
Display	Bosch INTUVIA
Battery	500 Wh
Battery type	Integrated
Frame	Aluminium 6061, R2 Sport, tapered, for integrated Bosch Powertube battery
Fork	SR Suntour MOBIE 25, air-suspended, lockout, tapered, for 15 mm quick release axle
Gears	Shimano SLX, 10-gear
Shifter	Shimano Deore, Rapidfire Plus
Pedal crank	Aluminium GEN2
Chain/belt	KMC X10E
Brake	Shimano, hydraulic disc brake
Brake lever	Shimano, for hydraulic disc brake
Tyre	Schwalbe MARATHON RACER 40-622, RaceGuard
Front wheel hub	Shimano Deore, centre lock, for 15 mm quick release axle
Rear wheel hub	Shimano Deore, centre lock, for 12 mm quick release axle
Spokes	Stainless steel, black
Handlebars	Men's and trapezoidal: Trekking, Semi Riser DB, oversized/wave: Metro, oversized
Stem/handlebars shaft	A-head, adjustable, aluminium
Handles	Ergon
Saddle	Ergon SFC30
Seat post	Patent, aluminium
Headlight	Herrmans H-Black MR8; up to 50 lux/180 lumens
Rear light	IVALO, integrated into the pannier rack
Pannier rack	Racktime, with SnapIt system, aluminium, with integrated rear light
Protective plate	SKS, plastic
Locks	ABUS battery lock, with Plus cylinder
Stand	Pletscher Comp Flex 40
Charger (included in supply)	Bosch 4A charger

Table 39: Futura Comp I parts list

Model	Futura Pro I
Type no.	19-Q-0098, 19-Q-0099, 19-Q-0100
Motor	Bosch PERFORMANCE CX mid-motor, 250 Watt, with free-wheeling
Display	Bosch INTUVIA
Battery	500 Wh
Battery type	Integrated
Frame	Aluminium 6061, R2 Sport, tapered, for integrated Bosch Powertube battery
Fork	SR Suntour MOBIE 25, air-suspended, lockout, tapered, for 15 mm quick release axle
Gears	Shimano Deore XT, 11-gear
Shifter	Shimano Deore XT, Rapidfire Plus
Pedal crank	Aluminium GEN2
Chain/belt	KMC X11E
Brake	Shimano Deore, hydraulic disc brake
Brake lever	Shimano Deore, for hydraulic disc brake
Tyre	Schwalbe ENERGIZER PRO, 40-622, RaceGuard
Front wheel hub	Shimano Deore, centre lock, for 15 mm quick release axle
Rear wheel hub	Shimano Deore, centre lock, for 12 mm quick release axle
Spokes	Stainless steel, black
Handlebars	Men's and trapezoidal: Trekking, Semi Riser DB, oversized/wave: Metro, oversized
Stem/handlebars shaft	A-head, adjustable, aluminium
Handles	Ergon
Saddle	Ergon SFC30
Seat post	Patent, aluminium
Headlight	Herrmans H-Black Pro LED; up to 100 lux/230 lumens
Rear light	IVALO, integrated into the pannier rack
Pannier rack	Racktime, with SnapIt system, aluminium, with integrated rear light
Protective plate	SKS, plastic
Locks	ABUS battery lock, with Plus cylinder
Stand	Pletscher Comp Flex 40
Charger (included in supply)	Bosch 4A charger

Table 40: **Futura Pro I parts list**

Model	Futura Pro I-F14
Type no.	19-Q-0055, 19-Q-0056, 19-Q-0057
Motor	Bosch PERFORMANCE CX mid-motor, 250 Watt, with free-wheeling
Display	Bosch INTUVIA
Battery	500 Wh
Battery type	Integrated
Frame	Aluminium 6061, R2 Sport, tapered, for integrated Bosch Powertube battery
Fork	SR Suntour MOBIE 25, air-suspended, lockout, tapered, for 15 mm quick release axle
Gears	Rohloff Speedhub, 14-gear
Shifter	Rohloff E-14, electronic
Pedal crank	Aluminium GEN2
Chain/belt	KMC
Brake	Shimano Deore, hydraulic disc brake
Brake lever	Shimano Deore, for hydraulic disc brake
Tyre	Marathon Plus 47-622, SmartGuard
Front wheel hub	Shimano Deore, centre lock, for 15 mm quick release axle
Rear wheel hub	Rohloff Speedhub, 14G
Spokes	Stainless steel, black
Handlebars	Men's and trapezoidal: Trekking, Semi Riser DB, oversized/wave: Metro, oversized
Stem/handlebars shaft	A-head, adjustable, aluminium
Handles	Ergon
Saddle	Ergon SFC30
Seat post	Patent, aluminium
Headlight	Herrmans H-Black Pro LED; up to 100 lux/230 lumens
Rear light	IVALO, integrated into the pannier rack
Pannier rack	Racktime, with SnapIt system, aluminium, with integrated rear light
Protective plate	SKS, plastic
Locks	ABUS battery lock, with Plus cylinder
Stand	Pletscher Comp Flex 40
Charger (included in supply)	Bosch 4A charger

Table 41: **Futura Pro I-F14 parts list**

Model	Futura Pro I-F360
Type no.	19-Q-0058, 19-Q-0059, 19-Q-0060
Motor	Bosch PERFORMANCE mid-motor, 250 Watt, with free-wheeling
Display	Bosch INTUVIA
Battery	500 Wh
Battery type	Integrated
Frame	Aluminium 6061, R2 Sport, tapered, for integrated Bosch Powertube battery
Fork	SR Suntour MOBIE 25, air-suspended, lockout, tapered, for 15 mm quick release axle
Gears	Enviolo TR, infinitely adjustable shifting hub
Shifter	Enviolo TR, manual twist grip
Pedal crank	Aluminium GEN2
Chain/belt	Continental Carbon belt
Brake	Shimano Deore, hydraulic disc brake
Brake lever	Shimano Deore, for hydraulic disc brake
Tyre	Marathon Plus 47-622, SmartGuard
Front wheel hub	Shimano Deore, centre lock, for 15 mm quick release axle
Rear wheel hub	Enviolo TR, disc
Spokes	Stainless steel, black
Handlebars	Men's and trapezoidal: Trekking, Semi Riser DB, oversized/wave: Metro, oversized
Stem/handlebars shaft	A-head, adjustable, aluminium
Handles	Ergon
Saddle	Ergon SFC30
Seat post	Patent, aluminium
Headlight	Herrmans H-Black Pro LED; up to 100 lux/230 lumens
Rear light	IVALO, integrated into the pannier rack
Pannier rack	Racktime, with SnapIt system, aluminium, with integrated rear light
Protective plate	SKS, plastic
Locks	ABUS battery lock, with Plus cylinder
Stand	Pletscher Comp Flex 40
Charger (included in supply)	Bosch 4A charger

Table 42: **Futura Pro I-F360 parts list**

Model	Futura Sport I
Type no.	19-Q-101, 19-Q-102, 19-Q-103
Motor	Bosch PERFORMANCE CX mid-motor, 250 Watt, with free-wheeling
Display	Bosch INTUVIA
Battery	500 Wh
Battery type	Integrated
Frame	Aluminium 6061, R2 Sport, tapered, for integrated Bosch Powertube battery
Fork	SR Suntour NEX-E25, with adjustable spring hardness, tapered
Gears	Shimano Deore, 9-gear
Shifter	Shimano Altus, Rapidfire Plus
Pedal crank	Aluminium GEN2
Chain/belt	KMC X9E
Brake	Shimano, hydraulic disc brake
Brake lever	Shimano, for hydraulic disc brake
Tyre	Schwalbe ENERGIZER ACTIVE Plus 40-622, PunctureGuard
Front wheel hub	Shimano, centre lock, with quick release
Rear wheel hub	Shimano, centre lock, with quick release
Spokes	Stainless steel, black
Handlebars	Men's and trapezoidal: Trekking, Semi Riser DB, oversized/wave: Metro, oversized
Stem/handlebars shaft	A-head, adjustable, aluminium
Handles	Men's and trapezoidal: Ergo, with integrated clamping and bar ends/wave: Ergo, with integrated clamping
Saddle	Selle Royal Ariel Unisex
Seat post	Patent, aluminium
Headlight	Herrmans H-Black MR8; up to 50 lux/180 lumens
Rear light	IVALO, integrated into the pannier rack
Pannier rack	Racktime, with SnapIt system, aluminium, with integrated rear light
Protective plate	SKS, plastic
Locks	ABUS battery lock, with Plus cylinder
Stand	Pletscher Comp Flex 40
Charger (included in supply)	Bosch 4A charger

Table 43: Futura Sport I parts list

Model	Futura Sport I 8.1
Type no.	19-Q-0064, 19-Q-0065, 19-Q-0066
Motor	Bosch PERFORMANCE CX mid-motor, 250 Watt, with free-wheeling
Display	Bosch INTUVIA
Battery	500 Wh
Battery type	Integrated
Frame	Aluminium 6061, R2 Sport, tapered, for integrated Bosch Powertube battery
Fork	SR Suntour NEX-E25, with adjustable spring hardness, tapered
Gears	Shimano Acera, 8-gear
Shifter	Shimano Altus, Rapidfire Plus
Pedal crank	Aluminium GEN2
Chain/belt	KMC
Brake	Shimano, hydraulic disc brake
Brake lever	Shimano, for hydraulic disc brake
Tyre	Schwalbe ENERGIZER ACTIVE Plus 40-622, PunctureGuard
Front wheel hub	Shimano, centre lock, with quick release
Rear wheel hub	Shimano, centre lock, with quick release
Spokes	Steel, black
Handlebars	Men's and trapezoidal: Trekking, Semi Riser, oversized/wave: Metro, oversized
Stem/handlebars shaft	A-head, adjustable, aluminium
Handles	Men's and trapezoidal: Ergo, with integrated clamping and bar ends/wave: Ergo, with integrated clamping
Saddle	Selle Royal Ariel Unisex
Seat post	Patent, aluminium
Headlight	Herrmans H-Black MR4; up to 40 lux/100 lumens
Rear light	Busch & Müller 2C, pannier rack LED rear light
Pannier rack	Racktime, with SnapIt system, aluminium
Protective plate	SKS, plastic
Locks	ABUS battery lock, with Plus cylinder
Stand	Pletscher Comp Flex 40
Charger (included in supply)	Bosch 4A charger

Table 44: **Futura Sport I 8.1 parts list**

Model	Futura Sport I-F8
Type no.	19-Q-0070, 19-Q-0071, 19-Q-0101, 19-Q-0102
Motor	Bosch PERFORMANCE mid-motor, 250 Watt, with free-wheeling
Display	Bosch INTUVIA
Battery	500 Wh
Battery type	Integrated
Frame	Aluminium 6061, R2 Sport, tapered, for integrated Bosch Powertube battery
Fork	SR Suntour NEX-E25, with adjustable spring hardness, tapered
Gears	Shimano Alfine, 8-gear
Shifter	Shimano Alfine, Rapidfire Plus
Pedal crank	Aluminium GEN2
Chain/belt	Continental Carbon belt
Brake	Shimano, hydraulic disc brake
Brake lever	Shimano, for hydraulic disc brake
Tyre	Schwalbe MARATHON RACER 40-622, RaceGuard
Front wheel hub	Shimano, centre lock, with quick release
Rear wheel hub	Shimano Alfine, 8-gear, free-wheeling
Spokes	Stainless steel, black
Handlebars	Men's and trapezoidal: Trekking, Semi Riser DB, oversized/wave: Metro, oversized
Stem/handlebars shaft	A-head, adjustable, aluminium
Handles	Ergon
Saddle	Selle Royal Ariel Unisex
Seat post	Patent, aluminium
Headlight	Herrmans H-Black MR8; up to 50 lux/180 lumens
Rear light	IVALO, integrated into the pannier rack
Pannier rack	Racktime, with SnapIt system, aluminium, with integrated rear light
Protective plate	SKS, plastic
Locks	ABUS battery lock, with Plus cylinder
Stand	Pletscher Comp Flex 40
Charger (included in supply)	Bosch 4A charger

Table 45: **Futura Sport I-F8 parts list**

Model	Montfort F7
Type no.	19-Q-0003, 19-Q-0004
Motor	Bosch ACTIVE PLUS mid-motor, 250 Watt, with free-wheeling
Display	Bosch INTUVIA
Battery	400 Wh
Battery type	Pannier rack
Frame	Aluminium 7005 Tour
Fork	SR Suntour NEX-E25, with adjustable spring hardness
Gears	Shimano Nexus, 7-gear
Shifter	Shimano Nexus, twist grip
Pedal crank	Aluminium GEN3
Chain/belt	KMC
Brake	Magura HS-11, hydraulic rim brake
Brake lever	Magura HS-11
Tyre	Schwalbe ENERGIZER LIFE 40-622, KGuard
Front wheel hub	Shimano with quick release
Rear wheel hub	Shimano Nexus, 7-gear, with free-wheeling
Spokes	Stainless steel, black
Handlebars	Touring, aluminium
Stem/handlebars shaft	Aluminium, adjustable
Handles	Ergo, with integrated clamping
Saddle	Selle Royal Freeway City
Seat post	Patent, suspended, aluminium
Headlight	Herrmans H-Black MR8; up to 50 lux/180 lumens
Rear light	Busch & Müller 2C, pannier rack LED rear light
Pannier rack	I-Rack, aluminium with battery mount
Protective plate	SKS, plastic
Locks	AXA Solid Plus, with simultaneous locking battery lock
Stand	Pletscher Comp Flex 40
Charger (included in supply)	Bosch 4A charger

Table 46: Montfort F7 parts list

Model	Montfoort Plus F8
Type no.	19-Q-0006
Motor	Bosch ACTIVE PLUS mid-motor, 250 Watt, with free-wheeling
Display	Bosch INTUVIA
Battery	500 Wh
Battery type	Pannier rack
Frame	Aluminium 7005 Tour
Fork	SR Suntour NEX-E25, hydraulic lockout
Gears	Shimano Nexus, 8-gear
Shifter	Shimano Nexus, twist grip
Pedal crank	Aluminium GEN3
Chain/belt	KMC
Brake	Magura HS-22, hydraulic rim brake
Brake lever	Magura HS-22
Tyre	Schwalbe ENERGIZER PLUS 40-622, GreenGuard
Front wheel hub	Shimano with quick release
Rear wheel hub	Shimano Nexus, 8-gear, with free-wheeling
Spokes	Stainless steel, black
Handlebars	Touring, aluminium
Stem/handlebars shaft	Aluminium, adjustable without tools
Handles	Ergo, with integrated clamping
Saddle	Selle Royal Freeway City
Seat post	Patent, suspended, aluminium
Headlight	Herrmans H-Black MR8; up to 50 lux/180 lumens
Rear light	Busch & Müller 2C, pannier rack LED rear light
Pannier rack	I-Rack, aluminium with battery mount
Protective plate	SKS, plastic
Locks	AXA Solid Plus, with simultaneous locking battery lock
Stand	Pletscher Comp Flex 40
Charger (included in supply)	Bosch 4A charger

Table 47: **Montfoort Plus F8 parts list**

Model	Rob Cargo R7
Type no.	19-X-0082
Motor	Bosch ACTIVE PLUS mid-motor, 250 Watt, with backpedal
Display	Bosch INTUVIA
Battery	500 Wh
Battery type	Standard
Frame	Aluminium 7005, with mounts for Racktime BoxIt, reinforced
Fork	Rigid
Gears	Shimano Nexus, 7-gear
Shifter	Shimano Nexus, twist grip
Pedal crank	Aluminium GEN3
Chain/belt	KMC
Brake	Magura HS-11, hydraulic rim brake
Brake lever	Magura HS-11
Tyre	Schwalbe BIG BEN 55-507, RaceGuard
Front wheel hub	Shimano with quick release
Rear wheel hub	Shimano Nexus, 7-gear, with back-pedal brake
Spokes	Stainless steel, RW, reinforced
Handlebars	Metro, aluminium, oversized
Stem/handlebars shaft	Aluminium A-head, height-adjustable with Speedlifter® Classic
Handles	Ergon
Saddle	Selle Royal Nuvola
Seat post	Patent, suspended, aluminium
Headlight	Busch und Müller IQ Avy, up to 30 lux
Rear light	Busch & Müller Toplight View
Pannier rack	Racktime SnapIt, including Racktime BoxIt system baskets (RW: large: 18L/FW; small 13L)
Protective plate	SKS, plastic
Locks	ABUS battery lock, with Plus cylinder
Stand	Ursus JUMBO two-leg stand
Charger (included in supply)	Bosch 4A charger

Table 48: Rob Cargo R7 parts list

Model	Rob Fold 8 Carbon
Type no.	19-Y-0006
Motor	Bosch PERFORMANCE mid-motor, 250 Watt, with free-wheeling
Display	Bosch INTUVIA
Battery	500 Wh
Battery type	Standard
Frame	Carbon, foldable
Fork	Rigid
Gears	Shimano Alfine, 8-gear
Shifter	Shimano Alfine, Rapidfire Plus
Pedal crank	Aluminium GEN2
Chain/belt	KMC
Brake	Magura HS-22, hydraulic rim brake
Brake lever	Magura HS-22
Tyre	Schwalbe BIG APPLE 50-406, RaceGuard
Front wheel hub	Shimano with quick release
Rear wheel hub	Shimano Alfine, 8-gear, with free-wheeling
Spokes	Stainless steel, black
Handlebars	Trekking Semi Riser DB, oversized
Stem/handlebars shaft	Speedlifter® Twist, 140 mm, with A-head stem
Handles	Ergon
Saddle	Ergon SM30
Seat post	Patent, aluminium, 400 mm
Headlight	Busch und Müller IQ Avy, up to 30 lux
Rear light	Integrated into the pannier rack
Pannier rack	I-Rack, aluminium with integrated rear light
Protective plate	SKS, plastic
Locks	ABUS battery lock, with Plus cylinder
Stand	Aluminium, 2-leg stand
Charger (included in supply)	Bosch 4A charger

Table 49: Rob Fold 8 Carbon parts list

Model	Rob Fold 9
Type no.	19-Y-0005
Motor	Bosch ACTIVE PLUS mid-motor, 250 Watt, with free-wheeling
Display	Bosch INTUVIA
Battery	500 Wh
Battery type	Standard
Frame	Aluminium 7005, foldable
Fork	Rigid
Gears	Shimano Deore XT, 9-gear
Shifter	Shimano Alivio, Rapidfire Plus
Pedal crank	Aluminium GEN3
Chain/belt	KMC
Brake	Magura HS-22, hydraulic rim brake
Brake lever	Magura HS-22
Tyre	Schwalbe BIG APPLE 50-406, RaceGuard
Front wheel hub	Shimano with quick release
Rear wheel hub	Shimano with quick release
Spokes	Stainless steel, RW, reinforced
Handlebars	Metro, aluminium, oversized
Stem/handlebars shaft	Speedlifter® Twist, 140 mm, with A-head stem
Handles	Ergo, with integrated clamping
Saddle	Selle Royal Nuvola
Seat post	Patent, aluminium, 400 mm
Headlight	Herrmans H-Black MR4; up to 40 lux/100 lumens
Rear light	Busch & Müller 2C, pannier rack LED rear light
Pannier rack	I-Rack, aluminium
Protective plate	SKS, plastic
Locks	ABUS battery lock, with Plus cylinder
Stand	Aluminium, rear stand, adjustable
Charger (included in supply)	Bosch 2A compact charger
Table 50:	Rob Fold 9 parts list

Model	Rob Fold F8
Type no.	19-Y-0004
Motor	Bosch ACTIVE PLUS mid-motor, 250 Watt, with free-wheeling
Display	Bosch INTUVIA
Battery 1	500 Wh
Battery 2	400 Wh
Battery type	Standard
Frame	Aluminium 7005, foldable
Fork	Rigid
Gears	Shimano Nexus, 8-gear
Shifter	Shimano Nexus, twist grip
Pedal crank	Aluminium GEN3
Chain/belt	KMC
Brake	Magura HS-22, hydraulic rim brake
Brake lever	Magura HS-22
Tyre	Schwalbe BIG APPLE 50-406, RaceGuard
Front wheel hub	Shimano with quick release
Rear wheel hub	Shimano Nexus, 8-gear, with free-wheeling
Spokes	Stainless steel, RW, reinforced
Handlebars	Metro, aluminium, oversized
Stem/handlebars shaft	Speedlifter® Twist, 140 mm, with A-head stem
Handles	Ergon
Saddle	Selle Royal LookIn Relaxed
Seat post	Patent, aluminium, 400 mm
Headlight	Busch und Müller IQ Avy, up to 30 lux
Rear light	Busch & Müller 2C, pannier rack LED rear light
Pannier rack	I-Rack, aluminium
Protective plate	SKS, plastic
Locks	ABUS battery lock, with Plus cylinder
Stand	Aluminium, 2-leg stand
Charger (included in supply)	Bosch 4A charger

Table 51: Rob Fold 8 parts list

Model	Rob Fold I-F8
Type no.	19-Y-0007
Motor	Bosch ACTIVE PLUS mid-motor, 250 Watt, with free-wheeling
Display	Bosch INTUVIA
Battery	500 Wh
Battery type	Integrated
Frame	Aluminium 7005, foldable, for integrated Bosch Powertube battery
Fork	Rigid
Gears	Shimano Nexus, 8-gear
Shifter	Shimano Nexus, twist grip
Pedal crank	Aluminium GEN3
Chain/belt	KMC
Brake	Magura HSi-22, integrated hydraulic rim brake
Brake lever	Magura HSi-22
Tyre	Schwalbe BIG APPLE 50-406, RaceGuard
Front wheel hub	Aluminium, for 15 mm quick release axle
Rear wheel hub	Shimano Nexus, 8-gear, with free-wheeling
Spokes	Stainless steel, RW, reinforced
Handlebars	Metro, aluminium, oversized
Stem/handlebars shaft	Speedlifter® Twist, 140 mm, with A-head stem
Handles	Ergon
Saddle	Selle Royal LookIn Relaxed
Seat post	Patent, aluminium, 400 mm
Headlight	Busch und Müller IQ Avy, up to 30 lux
Rear light	Busch & Müller 2C, pannier rack LED rear light
Pannier rack	I-Rack, aluminium
Protective plate	SKS, plastic
Locks	ABUS battery lock, with Plus cylinder
Stand	Aluminium, 2-leg stand
Charger (included in supply)	Bosch 4A charger

Table 52: Rob Fold I-F8 parts list

Model	Rob Fold I-R8
Type no.	19-Y-0008
Motor	Bosch ACTIVE PLUS mid-motor, 250 Watt, with backpedal
Display	Bosch INTUVIA
Battery	500 Wh
Battery type	Integrated
Frame	Aluminium 7005, foldable, for integrated Bosch Powertube battery
Fork	Rigid
Gears	Shimano Nexus, 8-gear
Shifter	Shimano Nexus, twist grip
Pedal crank	Aluminium GEN3
Chain/belt	KMC
Brake	Magura HSi-22, integrated hydraulic rim brake
Brake lever	Magura HSi-22
Tyre	Schwalbe BIG APPLE 50-406, RaceGuard
Front wheel hub	Aluminium, for 15 mm quick release axle
Rear wheel hub	Shimano Nexus, 8-gear, with back-pedal brake
Spokes	Stainless steel, RW, reinforced
Handlebars	Metro, aluminium, oversized
Stem/handlebars shaft	Speedlifter® Twist, 140 mm, with A-head stem
Handles	Ergon
Saddle	Selle Royal LookIn Relaxed
Seat post	Patent, aluminium, 400 mm
Headlight	Busch und Müller IQ Avy, up to 30 lux
Rear light	Busch & Müller 2C, pannier rack LED rear light
Pannier rack	I-Rack, aluminium
Protective plate	SKS, plastic
Locks	ABUS battery lock, with Plus cylinder
Stand	Aluminium, 2-leg stand
Charger (included in supply)	Bosch 4A charger

Table 53: Rob Fold I-R8 parts list

Model	Rob Fold Pro I-F8
Type no.	19-Y-0009
Motor	Bosch ACTIVE PLUS mid-motor, 250 Watt, with free-wheeling
Display	Bosch INTUVIA
Battery	500 Wh
Battery type	Integrated
Frame	Aluminium 7005, foldable, for integrated Bosch Powertube battery
Fork	Rigid
Gears	Shimano Alfine, 8-gear
Shifter	Shimano Alfine, Rapidfire Plus
Pedal crank	Aluminium GEN3
Chain/belt	Contitech toothed belt
Brake	Magura HSi-22, integrated hydraulic rim brake
Brake lever	Magura HSi-22
Tyre	Schwalbe BIG APPLE 50-406, RaceGuard
Front wheel hub	Aluminium, for 15 mm quick release axle
Rear wheel hub	Shimano Alfine, 8-gear, with free-wheeling
Spokes	Stainless steel, RW, reinforced
Handlebars	Metro, aluminium, oversized
Stem/handlebars shaft	Speedlifter® Twist, 140 mm, with A-head stem
Handles	Ergon
Saddle	Selle Royal LookIn Relaxed
Seat post	Patent, aluminium, 400 mm
Headlight	Busch und Müller IQ Avy, up to 30 lux
Rear light	Busch & Müller 2C, pannier rack LED rear light
Pannier rack	I-Rack, aluminium
Protective plate	SKS, plastic
Locks	ABUS battery lock, with Plus cylinder
Stand	Aluminium, 2-leg stand
Charger (included in supply)	Bosch 4A charger

Table 54: **Rob Fold Pro I-F8 parts list**

Model	Rob Fold R8
Type no.	19-Y-0003
Motor	Bosch ACTIVE PLUS mid-motor, 250 Watt, with backpedal
Display	Bosch INTUVIA
Battery 1	500 Wh
Battery 2	400 Wh
Battery type	Standard
Frame	Aluminium 7005, foldable
Fork	Rigid
Gears	Shimano Nexus, 8-gear
Shifter	Shimano Nexus, twist grip
Pedal crank	Aluminium GEN3
Chain/belt	KMC
Brake	Magura HS-22, hydraulic rim brake
Brake lever	Magura HS-22
Tyre	Schwalbe BIG APPLE 50-406, RaceGuard
Front wheel hub	Shimano with quick release
Rear wheel hub	Shimano Nexus, 8-gear, with back-pedal brake
Spokes	Stainless steel, RW, reinforced
Handlebars	Metro, aluminium, oversized
Stem/handlebars shaft	Speedlifter® Twist, 140 mm, with A-head stem
Handles	Ergon
Saddle	Selle Royal LookIn Relaxed
Seat post	Patent, aluminium, 400 mm
Headlight	Busch und Müller IQ Avy, up to 30 lux
Rear light	Busch & Müller 2C, pannier rack LED rear light
Pannier rack	I-Rack, aluminium
Protective plate	SKS, plastic
Locks	ABUS battery lock, with Plus cylinder
Stand	Aluminium, 2-leg stand
Charger (included in supply)	Bosch 4A charger

Table 55: Rob Fold R8 parts list

Model	Robert/a deLuxe I-F8
Type no.	19-Q-0026, 19-Q-0027
Motor	Bosch ACTIVE PLUS mid-motor, 250 Watt, with free-wheeling
Display	Bosch INTUVIA
Battery	500 Wh
Battery type	Integrated
Frame	Aluminium 6061, R1 Tour, tapered, for integrated Bosch Powertube battery
Fork	SR Suntour, TR-HSI, adjustable spring hardness, hydraulic lockout, tapered
Gears	Shimano Nexus, 8-gear
Shifter	Shimano Nexus, 8-grip
Pedal crank	Aluminium GEN3
Chain/belt	KMC
Brake	Magura HSi-22, integrated hydraulic rim brake
Brake lever	Magura HSi-22
Tyre	Schwalbe MARATHON 47-622, GreenGuard
Front wheel hub	Shimano with quick release
Rear wheel hub	Shimano Nexus, 8-gear, with free-wheeling
Spokes	Stainless steel, RW, reinforced
Handlebars	Metro, aluminium, oversized
Stem/handlebars shaft	A-head, adjustable, aluminium
Handles	Herrmans Clik, ergonomic with integrated clamping
Saddle	Selle Bassano LEGGERA
Seat post	Patent, suspended, aluminium
Headlight	Herrmans H-Black MR4; up to 40 lux/100 lumens
Rear light	Busch & Müller 2C, pannier rack LED rear light
Pannier rack	Racktime, with SnapIt system, aluminium
Protective plate	SKS, plastic
Locks	ABUS Pro Shield 5850, with simultaneous locking battery lock
Stand	Pletscher Comp Flex 40
Charger (included in supply)	Bosch 4A charger

Table 56: **Robert/a deLuxe I F8 parts list**

Model	Robert/a deLuxe I-R8
Type no.	19-Q-0030, 19-Q-0031
Motor	Bosch ACTIVE PLUS mid-motor, 250 Watt, with backpedal
Display	Bosch INTUVIA
Battery	500 Wh
Battery type	Integrated
Frame	Aluminium 6061, R1 Tour, tapered, for integrated Bosch Powertube battery
Fork	SR Suntour, TR-HSI, adjustable spring hardness, hydraulic lockout, tapered
Gears	Shimano Nexus, 8-gear
Shifter	Shimano Nexus, twist grip
Pedal crank	Aluminium GEN3
Chain/belt	KMC
Brake	Magura HSi-22, integrated hydraulic rim brake
Brake lever	Magura HSi-22
Tyre	Schwalbe MARATHON 47-622, GreenGuard
Front wheel hub	Shimano with quick release
Rear wheel hub	Shimano Nexus, 8-gear, with back-pedal brake
Spokes	Stainless steel, RW, reinforced
Handlebars	Metro, aluminium, oversized
Stem/handlebars shaft	A-head, adjustable, aluminium
Handles	Herrmans Klik, ergonomic with integrated clamping
Saddle	Selle Bassano LEGGERA
Seat post	Patent, suspended, aluminium
Headlight	Herrmans H-Black MR4; up to 40 lux/100 lumens
Rear light	Busch & Müller 2C, pannier rack LED rear light
Pannier rack	Racktime, with SnapIt system, aluminium
Protective plate	SKS, plastic
Locks	ABUS Pro Shield 5850, with simultaneous locking battery lock
Stand	Pletscher Comp Flex 40
Charger (included in supply)	Bosch 4A charger

Table 57: **Robert/a deLuxe I R8 parts list**

Model	Robert/a F7 Active Plus
Type no.	19-Q-0010, 19-Q-0011
Motor	Bosch ACTIVE PLUS mid-motor, 250 Watt, with free-wheeling
Display	Bosch INTUVIA
Battery 1	500 Wh
Battery 2	400 Wh
Battery type	Pannier rack
Frame	Aluminium 6061 Pro, tour
Fork	SR Suntour CR85, with adjustable spring hardness
Gears	Shimano Nexus, 7-gear
Shifter	Shimano Nexus, twist grip
Pedal crank	Aluminium GEN3
Chain/belt	KMC
Brake	Magura HS-11, hydraulic rim brake
Brake lever	Magura HS-11
Tyre	Schwalbe CITIZEN, 42-622 (26": 47-559), Kguard
Front wheel hub	Aluminium
Rear wheel hub	Shimano Nexus, 7-gear, with free-wheeling
Spokes	Steel, galvanised
Handlebars	Metro, aluminium
Stem/handlebars shaft	Aluminium, adjustable
Handles	Herrmans Clik, ergonomic with integrated clamping
Saddle	Selle Bassano VOLARE
Seat post	Patent, aluminium
Headlight	AXA Blueline30, up to 30 lux
Rear light	AXA Blueline
Pannier rack	I-Rack, aluminium
Protective plate	SKS, plastic
Locks	ABUS battery lock, with Plus cylinder
Stand	Pletscher Comp Flex 40
Charger (included in supply)	Bosch 2A compact charger

Table 58: Robert/a F7 Active Plus parts list

Model	Robert/a F8
Type no.	19-Q-0042, 19-Q-0043, 19-Q-0044
Motor	Bosch ACTIVE PLUS mid-motor, 250 Watt, with free-wheeling
Display	Bosch INTUVIA
Battery 1	500 Wh
Battery 2	400 Wh
Battery type	Standard
Frame	Aluminium 6061, R3·Tour, tapered
Fork	SR Suntour CR85, with adjustable spring hardness
Gears	Shimano Nexus, 8-gear
Shifter	Shimano Nexus, twist grip
Pedal crank	Aluminium GEN3
Chain/belt	KMC
Brake	FW: Magura HS-22/RW: Magura Hsi-22, hydraulic rim brake
Brake lever	Magura HS-22
Tyre	Schwalbe MARATHON 47-622 (26": 47-559), GreenGuard
Front wheel hub	Aluminium
Rear wheel hub	Shimano Nexus, 8-gear, with free-wheeling
Spokes	Steel, black
Handlebars	Tour, aluminium, oversized
Stem/handlebars shaft	A-head, adjustable, aluminium
Handles	Herrmans Clik, ergonomic with integrated clamping
Saddle	Selle Bassano VOLARE
Seat post	Patent, suspended, aluminium
Headlight	AXA Blueline30, up to 30 lux
Rear light	AXA Blueline
Pannier rack	Racktime, with SnapIt system, aluminium
Protective plate	SKS, plastic
Locks	ABUS battery lock, with Plus cylinder
Stand	Pletscher Comp Flex 40
Charger (included in supply)	Bosch 2A compact charger

Table 59: **Robert/a F8 parts list**

Model	Robert/a Pro I-F8
Type no.	19-Q-0032, 19-Q-0033
Motor	Bosch ACTIVE PLUS mid-motor, 250 Watt, with free-wheeling
Display	Bosch INTUVIA
Battery	500 Wh
Battery type	Integrated
Frame	Aluminium 6061, R1 Tour, tapered, for integrated Bosch Powertube battery
Fork	SR Suntour, TR-HSI, adjustable spring hardness, hydraulic lockout, tapered
Gears	Shimano Nexus, 8-gear
Shifter	Shimano Nexus, twist grip
Pedal crank	Aluminium GEN3
Chain/belt	Contitech toothed belt
Brake	Magura HSi-22, integrated hydraulic rim brake
Brake lever	Magura HSi-22
Tyre	Schwalbe MARATHON PLUS, 47-622, SmartGuard, non-puncture
Front wheel hub	Shimano Alivio, with quick release
Rear wheel hub	Shimano Nexus, 8-gear, with free-wheeling
Spokes	Stainless steel, RW, reinforced
Handlebars	Metro, aluminium, oversized
Stem/handlebars shaft	A-head, adjustable, aluminium
Handles	Ergon
Saddle	Selle Bassano LEGGERA
Seat post	Patent, suspended, aluminium
Headlight	Herrmans H-Black Pro LED; up to 100 lux/230 lumens
Rear light	IVALO, integrated into the pannier rack
Pannier rack	Racktime, with SnapIt system, aluminium, with integrated rear light
Protective plate	SKS, plastic
Locks	ABUS Pro Shield 5850, with simultaneous locking battery lock
Stand	Pletscher Comp Flex 40
Charger (included in supply)	Bosch 4A charger

Table 60: **Robert/a Pro I-F8 parts list**

Model	Robert/a Pro I-R8
Type no.	19-Q-0034, 19-Q-0035
Motor	Bosch ACTIVE PLUS mid-motor, 250 Watt, with backpedal
Display	Bosch INTUVIA
Battery	500 Wh
Battery type	Integrated
Frame	Aluminium 6061, R1 Tour, tapered, for integrated Bosch Powertube battery
Fork	SR Suntour, TR-HSI, adjustable spring hardness, hydraulic lockout, tapered
Gears	Shimano Nexus, 8-gear
Shifter	Shimano Nexus, twist grip
Pedal crank	Aluminium GEN3
Chain/belt	Contitech toothed belt
Brake	Magura HSi-22, integrated hydraulic rim brake
Brake lever	Magura HSi-22
Tyre	Schwalbe MARATHON PLUS, 47-622, SmartGuard, non-puncture
Front wheel hub	Shimano Alivio, with quick release
Rear wheel hub	Shimano Nexus, 8-gear, with back-pedal brake
Spokes	Stainless steel, RW, reinforced
Handlebars	Metro, aluminium, oversized
Stem/handlebars shaft	A-head, adjustable, aluminium
Handles	Ergon
Saddle	Selle Bassano LEGGERA
Seat post	Patent, suspended, aluminium
Headlight	Herrmans H-Black Pro LED; up to 100 lux/230 lumens
Rear light	IVALO, integrated into the pannier rack
Pannier rack	Racktime, with SnapIt system, aluminium, with integrated rear light
Protective plate	SKS, plastic
Locks	ABUS Pro Shield 5850, with simultaneous locking battery lock
Stand	Pletscher Comp Flex 40
Charger (included in supply)	Bosch 4A charger

Table 61: **Robert/a Pro I-R8 parts list**

Model	Robert/a Pro R8
Type no.	19-Q-0040, 19-Q-0041
Motor	Bosch ACTIVE PLUS mid-motor, 250 Watt, with backpedal
Display	Bosch INTUVIA
Battery 1	500 Wh
Battery 2	400 Wh
Battery type	Standard
Frame	Aluminium 6061, R3-Tour, tapered
Fork	SR Suntour, TR-HSI, adjustable spring hardness, hydraulic lockout, tapered
Gears	Shimano Nexus, 8-gear
Shifter	Shimano Nexus, twist grip
Pedal crank	Aluminium GEN3
Chain/belt	KMC
Brake	Magura HSi-22, integrated hydraulic rim brake
Brake lever	Magura HSi-22
Tyre	Schwalbe MARATHON PLUS, 47-622, SmartGuard, non-puncture
Front wheel hub	Shimano with quick release
Rear wheel hub	Shimano Nexus, 8-gear, with back-pedal brake
Spokes	Stainless steel, RW, reinforced
Handlebars	Tour, aluminium, oversized
Stem/handlebars shaft	A-head, adjustable, aluminium
Handles	Herrmans Clik, ergonomic with integrated clamping
Saddle	Selle Bassano LEGGERA
Seat post	Patent, suspended, aluminium
Headlight	Herrmans H-Black MR4; up to 40 lux/100 lumens
Rear light	Busch & Müller 2C, pannier rack LED rear light
Pannier rack	Racktime, with SnapIt system, aluminium
Protective plate	SKS, plastic
Locks	ABUS battery lock, with Plus cylinder
Stand	Pletscher Comp Flex 40
Charger (included in supply)	Bosch 4A charger

Table 62: Robert/a Pro R8 parts list

Model	Robert/a R7 Active Plus
Type no.	19-Q-0010, 19-Q-0011
Motor	Bosch ACTIVE PLUS mid-motor, 250 Watt, with backpedal
Display	Bosch INTUVIA
Battery 1	500 Wh
Battery 2	400 Wh
Battery type	Pannier rack
Frame	Aluminium 6061 Pro, tour
Fork	SR Suntour CR85, with adjustable spring hardness
Gears	Shimano Nexus, 7-gear
Shifter	Shimano Nexus, twist grip
Pedal crank	Aluminium GEN3
Chain/belt	KMC
Brake	Magura HS-11, hydraulic rim brake
Brake lever	Magura HS-11
Tyre	Schwalbe CITIZEN, 42-622 (26": 47-559), Kguard
Front wheel hub	Aluminium
Rear wheel hub	Shimano Nexus, 7-gear, with back-pedal brake
Spokes	Steel, galvanised
Handlebars	Metro, aluminium
Stem/handlebars shaft	Aluminium, adjustable
Handles	Herrmans Klik, ergonomic with integrated clamping
Saddle	Selle Bassano VOLARE
Seat post	Patent, aluminium
Headlight	AXA Blueline30, up to 30 lux
Rear light	AXA Blueline
Pannier rack	I-Rack, aluminium
Protective plate	SKS, plastic
Locks	ABUS battery lock, with Plus cylinder
Stand	Pletscher Comp Flex 40
Charger (included in supply)	Bosch 2A compact charger

Table 63: Robert/a R7 Active Plus parts list

Model	Robert/a R8
Type no.	19-Q-0046, 19-Q-0047
Motor	Bosch ACTIVE PLUS mid-motor, 250 Watt, with backpedal
Display	Bosch INTUVIA
Battery	500 Wh
Battery type	400 Wh
Frame	Standard
Fork	Aluminium 6061, R3-Tour, tapered
Gears	SR Suntour CR85, with adjustable spring hardness
Shifter	Shimano Nexus, 8-gear
Pedal crank	Shimano Nexus, twist grip
Chain/belt	Aluminium GEN3
Brake	KMC
Brake lever	FW: Magura HS-22/RW: Magura Hsi-22, hydraulic rim brake
Tyre	Magura HS-22
Front wheel hub	Schwalbe MARATHON 47-622 (26": 47-559), GreenGuard
Rear wheel hub	Aluminium
Spokes	Shimano Nexus, 8-gear, with back-pedal brake
Handlebars	Steel, black
Stem/handlebars shaft	Tour, aluminium, oversized
Handles	A-head, adjustable, aluminium
Saddle	Herrmans Clik, ergonomic with integrated clamping
Seat post	Selle Bassano VOLARE
Headlight	Patent, suspended, aluminium
Rear light	AXA Blueline30, up to 30 lux
Pannier rack	AXA Blueline
Protective plate	Racktime, with SnapIt system, aluminium
Locks	SKS, plastic
Stand	ABUS battery lock, with Plus cylinder
Charger (included in supply)	Pletscher Comp Flex 40 Bosch 2A compact charger

Table 64: **Robert/a R8 parts list**

Model	Viverty E F7
Type no.	19-Q-0007
Motor	Bosch ACTIVE PLUS mid-motor, 250 Watt, with free-wheeling
Display	Bosch INTUVIA
Battery	500 Wh
Battery type	400 Wh
Frame	Pannier rack
Fork	Aluminium 7005 Touring, with welded-on pannier rack, including battery mount
Gears	Rigid
Shifter	Shimano Nexus, 7-gear
Pedal crank	Shimano Nexus, twist grip
Chain/belt	Aluminium GEN3
Brake	KMC
Brake lever	Magura HS-11, hydraulic rim brake
Tyre	Magura HS-11
Front wheel hub	Schwalbe BIG BEN, 50-622, KGuard
Rear wheel hub	Shimano with quick release
Spokes	Shimano Nexus, 7-gear, with free-wheeling
Handlebars	Stainless steel
Stem/handlebars shaft	Touring, aluminium
Handles	Aluminium, rigid, 30° angle
Saddle	Ergo, coloured
Seat post	Touring, with extension & compression springs
Headlight	Patent, aluminium
Rear light	Retro, LED
Pannier rack	R99-EB pannier rack rear light, LED
Protective plate	I-Rack, aluminium with battery mount, welded on
Locks	Steel, painted in frame colour
Stand	ABUS battery lock, with Plus cylinder
Charger (included in supply)	Pletscher Comp Flex 40 Bosch 2A compact charger

Table 65: **Viverty E F7 parts list**

Model	Viverty E R7
Type no.	19-Q-0008
Motor	Bosch ACTIVE PLUS mid-motor, 250 Watt, with backpedal
Display	Bosch INTUVIA
Battery 1	500 Wh
Battery 2	400 Wh
Battery type	Pannier rack
Frame	Aluminium 7005 Touring, with welded-on pannier rack, including battery mount
Fork	Rigid
Gears	Shimano Nexus, 7-gear
Shifter	Shimano Nexus, twist grip
Pedal crank	Aluminium GEN3
Chain/belt	KMC
Brake	Magura HS-11, hydraulic rim brake
Brake lever	Magura HS-11
Tyre	Schwalbe BIG BEN, 50-622, KGuard
Front wheel hub	Shimano with quick release
Rear wheel hub	Shimano Nexus, 7-gear, with back-pedal brake
Spokes	Stainless steel
Handlebars	Touring, aluminium
Stem/handlebars shaft	Aluminium, rigid, 30° angle
Handles	Ergo, coloured
Saddle	Touring, with extension & compression springs
Seat post	Patent, aluminium
Headlight	Retro, LED
Rear light	R99-EB pannier rack rear light, LED
Pannier rack	I-Rack, aluminium with battery mount, welded on
Protective plate	Steel, painted in frame colour
Locks	ABUS battery lock, with Plus cylinder
Stand	Pletscher Comp Flex 40
Charger (included in supply)	Bosch 2A compact charger

Table 66: **Viverty E R7 parts list**

10.4**Table of figures**

Figure 1:	Type plate, example, 21
Figure 2:	Bicycle, viewed from the right, example of City Cruiser, 28
Figure 3:	Detailed view of bicycle from rider position, example, 29
Figure 4:	Components of the wheel, example of front wheel, 30
Figure 5:	Bicycle without suspension (1) and with suspension (2) when riding over an obstacle, 31
Figure 6:	Example: Suntour fork – The stem and handlebars are fastened to the fork shaft (1). The wheel is fastened to the quick release axle (5). Other elements: The compression setting (2) crown (3) Q-Loc (4) fork end for quick release (6) stanchion (7) suspension (8), 32
Figure 7:	Rim brake components with details – example: Magura HS22, 33
Figure 8:	<i>Rim brake locking lever</i> , closed (1) and open (2), 34
Figure 9:	Bicycle brake system with a disc brake, example, 35
Figure 10:	Brake system with a back-pedal brake, example, 36
Figure 11:	Diagram of mechanical drive system, 37
Figure 12:	Diagram of electric drive system, 38
Figure 13:	Details of the down tube battery, 40
Figure 14:	Details of pannier rack battery, 41
Figure 15:	Integrated battery details, 42
Figure 16:	Overview of the structure of the display's operating elements, 44
Figure 17:	Overview of the displays, 45
Figure 18:	Overview of the control panel, 52
Figure 19:	Fastening the transport securing device, 58
Figure 20:	Fully inserting the axle, 66
Figure 21:	Tightening the axle, 66
Figure 22:	Pushing the quick release lever into the axle, 67
Figure 23:	Tightening the securing screw, 67
Figure 24:	Tightening the inserted axle, 68
Figure 25:	Tightening the axle, 68
Figure 26:	Pushing the axle into the hub, 70
Figure 27:	Tightening the axle, 70
Figure 28:	Pushing the quick release lever into the axle, 71
Figure 29:	Securing the lever, 71
Figure 30:	Perfect position for the clamping lever, 72
Figure 31:	Adjusting the quick release clamping force, 72
Figure 32:	Open and closed flange, 74

- Figure 33: Pushing the quick release in, 74
- Figure 34: Adjusting the clamping, 75
- Figure 35: Closing the quick release, 75
- Figure 36: Horizontal saddle tilt, 80
- Figure 37: Optimal saddle height, 81
- Figure 38: Seat post quick release (3) with clamping lever (5) and adjustment screw (4) in the open position (1) and in the direction of the closed position (2), 81
- Figure 39: Detailed view of the seat post – examples of the minimum insertion depth marking, 82
- Figure 40: The seat post activation lever can be mounted either on the left (1) or the right (2) side of the handlebars, 83
- Figure 41: Knee cap perpendicular line, 84
- Figure 42: Open (2) and closed (1) clamping lever on the stem – example: by.schulz speed lifter, 86
- Figure 43: Pulling locking lever upwards – example: by.schulz speed lifter, 87
- Figure 44: Using the twist knob (1) to adjust the pressure point, 89
- Figure 45: Brake lever grip distance, 90
- Figure 46: Using the setting screw (2) to adjust the distance from the brake lever to the handlebar grip (1), 91
- Figure 47: Negative deflection setting wheel on the suspension fork crown, 92
- Figure 48: Screw caps in different designs, 94
- Figure 49: Removing and inserting the down tube battery, 105
- Figure 50: Removing and inserting the pannier rack battery, 106
- Figure 51: Removing the integrated battery, 107
- Figure 52: Inserting the integrated battery, 108
- Figure 53: Cover open contacts with cover cap – example: pannier rack battery, 112
- Figure 54: Push display (2) over the display catch (1) until it locks into the mount (3), 119
- Figure 55: Display with high (2) and low (1) gear recommendation, 126
- Figure 56: Down shifter (1) and up shifter (2) on the left (I) and right (II) shift, 127
- Figure 57: Example; Shimano Nexus gear shift: twist grip (1) for the hub gear with its screen (3), the direction of rotation to switch up a gear (2) and the direction of rotation to switch down a gear (4), 129

- Figure 58: Front (2) and rear (1) brake lever – example: Shimano brake, 134
- Figure 59: Pushing the pedal against the pedal crank (1), 135
- Figure 60: Folding the pedal up (I) or down (II), 136
- Figure 61: Opened clamping lever on the stem quick release (3) on the stem (2), version I, with locking lever on the stem (1), 136
- Figure 62: Stem, version II with clamping lever on the stem quick release (1) and unlocking knob (2), 137
- Figure 63: Frame, with closed frame clamping lever (1) and open frame locking lever (2), 138
- Figure 64: Frame, with closed frame clamping lever (1) and closed frame locking lever (2), 140
- Figure 65: Pushing the pedal against the pedal crank (1), 140
- Figure 66: Folding up the pedal, 140
- Figure 67: Checking the chain and belt tension, 154
- Figure 68: Adjusting the quick release clamping force, 159
- Figure 69: Adjusting the quick release clamping force, 159
- Figure 70: Dunlop valve with union nut (1) and rim nut (2), 160
- Figure 71: Presta valve with valve insert (1), knurled nut (2) and rim nut (3), 161
- Figure 72: Schrader valve with rim nut (1), 162
- Figure 73: Adjusting sleeve (1) for the single-cable cable-operated gear shift with shifter housing (2), example, 163
- Figure 74: Adjusting sleeves (2) on two alternative versions (A and B) of a dual-cable cable-operated gear shift on the chain stay (1), 164
- Figure 75: Twist grip with adjusting sleeves (1) and play of the gear shift (2), 165
- Figure 76: Brake lever (1) of the hydraulically operated rim brake with setting bolt (2), 166
- Figure 77: Trailer sign, 170

10.5 List of tables

Table 1:	Identification number of the operating instructions, 11
Table 2:	Type number, model and bicycle type categorisation, 11
Table 3:	Meanings of the signal words, 16
Table 4:	Meaning of safety markings, 17
Table 5:	Relevance of area of use, 18
Table 6:	Relevance of bicycle type, 18
Table 7:	Relevance of safety instructions, 19
Table 8:	Battery technical data, 40
Table 9:	Technical data, display battery, 43
Table 10:	Operating element overview, 44
Table 11:	USB port technical data, 45
Table 12:	Overview of the screen display, 45
Table 13:	Overview of levels of assistance, standard, 46
Table 14:	Overview of levels of assistance – eMTB mode, 47
Table 15:	Symbols of the gear recommendation function, 49
Table 16:	Journey information, 50
Table 17:	Changeable system settings, 50
Table 18:	System data, not changeable, 50
Table 19:	Overview of the control panel, 52
Table 20:	Bicycle technical data, 53
Table 21:	Battery technical data, 53
Table 22:	Display technical data, 54
Table 23:	Emissions from the bicycle*, 54
Table 24:	USB port technical data, 54
Table 25:	Tightening torque values*, 55
Table 26:	Storage temperature for the battery, the bicycle and the charger, 59
Table 27:	Working environment temperature, 61
Table 28:	Handlebars clamping screw maximum tightening torque, 85
Table 29:	Changing the system settings, 125
Table 30:	Accessories, 168
Table 31:	Error eradication using the code, 174
Table 32:	List of system messages, 178
Table 33:	Parts list for Cargo 500 0 S 9, 184
Table 34:	E-Imperial 180 S 9 parts list, 185
Table 35:	E-Imperial 180 S F8 parts list, 186
Table 36:	E-Imperial 180 S R8 parts list, 187
Table 37:	E-Joy F7 parts list, 188

Table 38:	E-Joy R7 parts list, 189
Table 39:	Futura Comp I parts list, 190
Table 40:	Futura Pro I parts list, 191
Table 41:	Futura Pro I-F14 parts list, 192
Table 42:	Futura Pro I-F360 parts list, 193
Table 43:	Futura Sport I parts list, 194
Table 44:	Futura Sport I 8.1 parts list, 195
Table 45:	Futura Sport I-F8 parts list, 196
Table 46:	Montfort F7 parts list, 197
Table 47:	Montfoort Plus F8 parts list, 198
Table 48:	Rob Cargo R7 parts list, 199
Table 49:	Rob Fold 8 Carbon parts list, 200
Table 50:	Rob Fold 9 parts list, 201
Table 51:	Rob Fold 8 parts list, 202
Table 52:	Rob Fold I-F8 parts list, 203
Table 53:	Rob Fold I-R8 parts list, 204
Table 54:	Rob Fold Pro I-F8 parts list, 205
Table 55:	Rob Fold R8 parts list, 206
Table 56:	Robert/a deLuxe I F8 parts list, 207
Table 57:	Robert/a deLuxe I R8 parts list, 208
Table 58:	Robert/a F7 Active Plus parts list, 209
Table 59:	Robert/a F8 parts list, 210
Table 60:	Robert/a Pro I-F8 parts list, 211
Table 61:	Robert/a Pro I-R8 parts list, 212
Table 62:	Robert/a Pro R8 parts list, 213
Table 63:	Robert/a R7 Active Plus parts list, 214
Table 64:	Robert/a R8 parts list, 215
Table 65:	Viverty E F7 parts list, 216
Table 66:	Viverty E R7 parts list, 217

10.6

Index

- A**
Alternative equipment, 20
- B**
Back-pedal brake, 33, 35, 36
-braking, 134
Battery, 40
- charging, 109, 111
- checking, 65
- disposing of, 177
- removing, 104, 106, 107
- waking, 113
Bell, 29
Belt tension, 153
Bike stand, see Kickstand
Brake arm, 33
Brake caliper, 35
Brake disc, 35
Brake lever, 29
- adjusting the pressure point 88
Brake lining, 33, 35
- maintaining, 152
Brake,
- using the transport securing system, 58
Back-pedal brake, 33, 35, 36
Break in operation, 59
- carrying out, 60
- preparing, 60
Button,
Driving light, 44
Info (control panel), 52
Info (display), 44
Minus, 52
On-Off (battery), 41, 42
On-Off (display), 44
Plus, 52
Push assist, 52
RESET, 44
- C**
Chain drive, 37
Chain guard, 28
- checking, 98
Chain tension, 153
Chain wheel, 37
Chain, 28, 37
- maintaining, 153
- replacing, 167
Charge status indicator, 42
Charger,
- disposing of, 177
Clamping force,
- Checking the quick releases, 70
- Setting the quick releases, 70
Control panel, 52
- D**
Damping, 31
Data sheet, 1
Direction of travel, 37
Display, 43
- attaching, 119
- charging the battery, 118, 119, 120, 121
- removing, 118
Down tube battery,
- removing, 104, 106, 107
Drive system, 37
- switching off, 115, 117
- switching on, 114, 116
Driving light button, 44
Driving light, 43
- checking function, 98
- replacing, 167
- E**
EC declaration of conformity, 183
- F**
Fork lock, 29
Fork, 30
- adjusting tyre pressure, 94
Fork end, 30
structure, 32
Frame number, 1
Frame, 28
Front wheel brake, 33, 35, 36
- braking, 134
Front wheel, see Wheel
- G**
Gear recommendation, 49
Gear shift twist grip,
- checking, 152
Gear shift,
- maintaining, 152
- switching, 126
- H**
Handlebars, 28, 29
Headlight 28, 29
Headlight, 38
Horn, see Bell
Hub, 30
- I**
Info button (display), 44
Info button, 52
Initial commissioning 63
- J**
Journey information, 50
- resetting, 123
- switching, 123
Average, 50
Clock, 50
Max Speed, 50
Odometer, 50
Range, 50
Trip distance, 50
Trip Time, 50
- L**
Level of assistance, 46, 47, 52
- selecting, 123
ECO, 46, 47
OFF, 46, 47
SPORT, 46
TOUR, 46, 47
TURBO, 46, 47
Lighting, see Driving light
- M**
Mass, see Weight
Minimum insertion depth marking, 82
Minus button, 52
Model year, 21
Model, 1
Motor, 38

Mudguards, 28
- checking, 98

O

On-Off button,
 Battery, 41, 42
 Display, 44
Operating status indicator, 42

P

Packaging, 62
Pannier rack, 28
 - changing, 101
 - checking, 98
 - using, 100
Parts list, 183
Pedal, 36, 37
Plus button, 52
Push assist,
 - using, 122
Pushing aid button, 52

Q

Quick release, 30

R

Rear light 28
Rear light, 38
Rear wheel brake, 35, 36
Rear wheel, see Wheel
Reflector, 28
RESET button, 44
Retainer guard, 42
Rim brake locking lever 34
Rim, 30
 - checking, 151
 - replacing, 167
Roller brake,
 -braking, 134

S

Saddle, 28
 - changing the saddle tilt,
 79
 - changing the seat length,
 84
 - determining the saddle
 height, 80, 84
Screen display, 45, 126, 170
Seat post, 28
 - clamping, 88, 90, 139
Securing hook, 42

Shifter, 29
 - checking, 152
 - setting, 155, 162, 163,
 166

Spoke, 30
Storage, 58
Storing, see Storage
Suspension fork, 31
Suspension head, 30
Suspension, 31
System message, 51
System setting, 50
 - changing, 124
 changeable, 50, 125
 System data, 50

T

Total journey duration, 50
Transportation, 56
Transporting, see
Transportation
Type number, 1, 21
Tyre pressure, 1
Tyre size, 1
Tyres, 30
 - checking, 151
 - replacing, 167

U

USB port, 44
 - using, 121

V

Valve, 30
 Dunlop valve, 30
 Presta valve, 30
 Schrader valve, 30

W

Weight,
 permitted total weight, 21
 Unladen weight, 1
Wheel circumference, 1
Wheel,
 - maintaining, 151
Winter break, see break in
operation
Working environment, 61

Text and images:
HERCULES GMBH
Longericher Straße 2
50739 Köln, Germany

Translation:
Tanner Translations GmbH+Co
Markenstraße 7
40227 Düsseldorf, Germany

Operating instructions: 034-11572_1.0_29.08.2018

www.hercules-bikes.de

HERCULES GMBH
Longericher Straße 2
50739 Köln, Germany

Tel.: +49 4471 18735-0

Fax: +49 4471 18735-29

E-Mail: info@hercules-bikes.de

YOUR HERCULES SPECIALIST DEALER

