

TRANSLATION OF THE ORIGINAL OPERATING INSTRUCTIONS

IMPORTANT

READ CAREFULLY BEFORE USE

KEEP SAFE TO CONSULT AT A LATER DATE



HERCULES



BOSCH



Pedelecs

Futura Compact 8, Futura Compact F8, Futura Compact R8 ZR 20 500Wh 8G blau46, Futura Sport 8.4, Futura Sport 8.5, Montfoort Cruise F7, Rob Cross Comp, Rob Cross Pro I, Rob Cross Sport, Rob Fold F7, Robert/a F7 ZR, Robert/a R7 ZR

20-Q-0022, 20 Q-0023, 20-Q-0024, 20-Q-0025, 20-Q-0026, 20-Q-0027, 20 Q-0061, 20-Q-0062, 20-Q-0067, 20-Q-0070, 20 Q-0071, 20-Q-0075, 20-Q-0076, 20-Q-0077, 20-Q-0078, 20 Q-0079, 20-Q-0083, 20-Q-0084, 20-Q-0085, 20 Q-0086, 20-Q-0087, 20-Q-0088, 20-Q-0089, 20-Q-0091, 20 Q-0092, 20-Q-0093, 20-Q-TBD, 20-Q-TBD, 20-Q-TBD, 20 Y 0012, 20-Y 0013

Contents

1	About these operating instructions	4	3.4.10	PowerPack 500 battery	27
1.1	Manufacturer	4	3.4.11	PowerTube battery	27
1.2	Type number and model	4	3.4.12	Purion display	27
1.3	Identifying the operating instructions	5	3.4.13	USB port	27
1.4	Laws, standards and directives	5	3.4.14	BOSCH Pedelec ABS BAS100	28
1.5	Subject to change	5	3.4.15	Emissions	28
1.6	Language	5	3.4.16	Tightening torque	28
1.7	For your safety	5	3.5	Environmental requirements	29
1.7.1	Instruction, training and customer service	5	3.6	Description of controls and screens	31
1.7.2	Basic safety instructions	5	3.6.1	Handlebars	31
1.7.3	Warnings	6	3.6.2	Battery level indicator	31
1.7.4	Safety markings	6	3.6.3	Control panel on-screen indicators	31
1.8	For your information	6	3.6.4	System message	34
1.8.1	Instructions for actions	6	3.6.5	ABS indicator lamp	35
1.8.2	Language conventions	6	4	Transporting and storing	36
1.9	Nameplate	7	4.1	Physical transport characteristics	36
1.9.1	Information on the nameplate	8	4.1.1	Dimensions during transportation	36
2	Safety	9	4.1.2	Transport weight	36
2.1	General warnings	9	4.1.3	Designated handles/lifting points	36
2.2	Toxic substances	10	4.2	Transporting	36
2.3	Requirements for the rider	11	4.2.1	Transporting the battery	37
2.4	Protection for vulnerable groups	11	4.2.2	Shipping the battery	37
2.5	Data privacy	11	4.2.3	Using the brake transport securing system	37
2.6	Personal protective equipment	11	4.3	Storing	37
2.7	Safety markings and safety instructions	11	4.3.1	Break in operation	38
2.8	Emergency	12	5	Assembly	39
2.8.1	What to do in an emergency	12	5.1	Required tools	39
2.8.2	First aid treatment	12	5.2	Unpacking	39
2.8.3	Fighting fire	12	5.2.1	Scope of delivery	39
2.8.4	Leaking fluids	13	5.3	Commissioning	40
3	Overview	14	5.3.1	Checking the battery	40
3.1	Description	15	5.3.2	Installing the wheel in the Suntour fork	40
3.1.1	Wheel and suspension	15	5.3.3	Installing the wheel with a quick release	43
3.1.2	Suspension	15	5.3.4	Installing the wheel in the FOX fork	44
3.1.3	Brake system	17	5.3.5	Pedelec sale	46
3.1.4	Electric drive system	20	6	Operation	47
3.1.5	Rechargeable battery	20	6.1	Risks and hazards	47
3.1.6	Control panel with display	22	6.1.1	Tips for a greater range	48
3.1.7	Riding light	23	6.1.2	Personal protective equipment	48
3.1.8	Charger	23	6.2	Error messages	49
3.2	Proper use	24	6.2.1	Error message display	49
3.3	Improper use	25	6.2.2	Battery error message	51
3.4	Technical data	26	6.3	Before the first ride	52
3.4.1	Pedelec	26	6.3.1	Adjusting the saddle	52
3.4.2	ActiveLine motor	26	6.3.2	Determining the seat height	52
3.4.3	ActiveLine Plus motor	26	6.3.3	Adjusting the handlebars	54
3.4.4	Performance Line Cruise motor	26	6.3.4	Adjusting the brake lever	55
3.4.5	Performance Line Speed motor	26	6.3.5	Adjusting the suspension of the Suntour fork	56
3.4.6	Performance Line CX motor	26	6.3.6	Adjusting the suspension of the FOX fork	58
3.4.7	Lighting	27	6.3.7	Setting the Suntour rear frame damper	60
3.4.8	PowerPack 300 battery	27			
3.4.9	PowerPack 400 battery	27			

6.3.8	Setting the FOX rear frame damper	61	6.14.5	Adjusting the rebound in a Rock Shox damper	81
6.3.9	Retracting the brake linings	62	6.14.6	Adjusting the compression in a Rock Shox damper	81
6.4	Accessories	63	6.15	Gear shift	81
6.4.1	Child seat	63	6.15.1	Using the derailleur gears	82
6.4.2	Bicycle trailers	64	6.15.2	Using a hub gear	82
6.4.3	Pannier rack	64	6.15.3	Use eShift	82
6.5	Before each ride	65	7	Cleaning and servicing	84
6.6	Check list before each ride	65	7.1	Cleaning after each ride	84
6.7	Using the kickstand	66	7.1.1	Cleaning the suspension fork	84
6.7.1	Raising the kickstand	66	7.1.2	Cleaning the rear frame damper	84
6.8	Using the pannier rack	66	7.1.3	Cleaning the pedals	84
6.9	Rechargeable battery	67	7.2	Basic cleaning	85
6.9.1	Frame battery	68	7.2.1	Cleaning the frame	85
6.9.1.2	Inserting the frame battery	68	7.2.2	Cleaning the stem	85
6.9.2	Pannier rack battery	68	7.2.3	Cleaning the rear frame damper	85
6.9.2.2	Inserting the pannier rack battery	68	7.2.4	Cleaning the wheel	85
6.9.3	Integrated battery	68	7.2.5	Cleaning the drive elements	85
6.9.3.1	Removing the integrated battery	68	7.2.6	Cleaning the chain	86
6.9.3.2	Inserting the integrated battery	69	7.2.7	Cleaning the battery	86
6.9.4	Charging the battery	69	7.2.8	Cleaning the display	86
6.9.5	Charging the dual battery	70	7.2.9	Cleaning the drive unit	86
6.9.5.1	Charging process when two batteries are used	70	7.2.10	Cleaning the brake	87
6.9.5.2	Charging process when one battery is used	71	7.3	Servicing	87
6.9.6	Waking the battery	71	7.3.1	Servicing the frame	87
6.10	Electric drive system	72	7.3.2	Servicing the stem	87
6.10.1	Switching on the electric drive system	72	7.3.3	Servicing the fork	87
6.10.2	Switching off the drive system	72	7.3.4	Servicing the drive elements	87
6.11	Control panel with display	73	7.3.5	Servicing the pedals	87
6.11.1	Using the USB port	73	7.3.6	Servicing the chain	87
6.11.2	Replacing the battery	73	7.3.7	Servicing the drive elements	87
6.11.3	Overview of actions	74	7.4	Maintenance	88
6.11.4	Switching on the display	74	7.4.1	Wheel	88
6.11.5	Switching off the display	74	7.4.2	Checking the tyres	88
6.12	Using the push assist system	74	7.4.3	Checking the rims	88
6.12.1	Using the riding light	75	7.4.4	Check and correct tyre pressure	88
6.12.2	Selecting the level of assistance	75	7.4.5	Brake system	89
6.12.3	Journey information	75	7.4.6	Checking the brake linings for wear	89
6.13	Brake	76	7.4.7	Checking the pressure point	89
6.13.1	Using the brake lever	77	7.4.8	Checking the brake discs for wear	90
6.13.2	Using the back-pedal brake	78	7.4.9	Electrical cables and brake cables	90
6.13.3	Using ABS	78	7.4.10	Gear shift	90
6.14	Suspension and damping	79	7.4.11	Stem	90
6.14.1	Adjusting the compression of the Fox fork	79	7.4.12	USB port	90
6.14.2	Adjusting the compression of the Fox damper	80	7.4.13	Checking the belt and chain tension	90
6.14.3	Adjusting the compression of the Suntour fork	80	7.4.14	Checking the handlebar grip position	90
6.14.4	Adjusting the compression of a Suntour damper	80	8	Maintenance	91
			8.1	Axle with quick release	92
			8.1.1	Checking the quick release	92
			8.2	Adjusting the gear shift	92
			8.2.1	Cable-operated gear shift, single-cable	93

8.2.2	Cable-operated gear shift, dual-cable	93
8.2.3	Cable-operated twist grip, dual-cable	93
9	Troubleshooting, fault clearance and repair	94
9.1	Troubleshooting and fault clearance	94
9.1.1	The drive system or display do not start up	94
9.1.2	Error messages	94
9.2	Repair	95
9.2.1	Use original parts and lubricants only	95
9.2.2	Replacing the lighting	95
9.2.3	Setting the headlight	95
10	Recycling and disposal	96
11	Documents	97
11.1	Parts list	97
11.2	Assembly report	98
11.3	Maintenance log	100
11.4	Charger operating instructions	103
12	Keyword index	112
13	Glossary	113
I.	EC declaration of conformity	116

1 About these operating instructions

Thank you for your trust!

HERCULES pedelecs are sporting equipment of the highest quality – you have made a good choice. Your specialist dealer has advised you and assembled your product. Whether maintenance, inspection, conversion or repair, your specialist dealer will also be happy to assist you in the future.

Notice

The *operating instructions* are not a substitute for personal instruction by the supplying specialist dealer.

The *operating instructions* are an integral part of the pedelec. Therefore, if it is re-sold at a later time, they must be handed over to the subsequent owner.

You receive these *operating instructions* with your new pedelec. Please take a little time to become familiar with your new pedelec and follow the tips and suggestions in the *operating instructions*. They will help you to enjoy your HERCULES pedelec for a long time to come. We hope you have fun and wish you well on all of your rides!

These operating instructions are designed for the rider and the operator of the pedelec to ensure that non-professionals can use the pedelec safely.



Instructions for the specialist dealer are highlighted in grey and marked with a symbol. Specialist dealers have specialist training and qualifications and are thus able to identify risks and prevent hazards which may arise during maintenance, servicing and repairs on the pedelec. Information for specialist staff does not require non-professionals to take any action.

You can download the *operating instructions* onto your mobile phone at the following address, so that you can use them when you are out riding:



<https://www.hercules-bikes.de/de/de/index/downloads.html>

1.1 Manufacturer

The pedelec manufacturer is:

HERCULES GMBH
Longericher Straße 2
50739 Köln, Germany

Tel.: +49 4471 18735 0
Fax: +49 4471 18735 29
E-mail: info@hercules-bikes.de
Internet: www.hercules-bikes.de

1.2 Type number and model

The *operating instructions* are an integral part of pedelecs with the following type numbers:

Type no.	Model	Pedelec type
20-Q-0022	Futura Sport 8.4 HE 28" 500Wh 8G	City and trekking bicycle
20-Q-0023	Futura Sport 8.4 TR 28" 500Wh 8G	City and trekking bicycle
20-Q-0024	Futura Sport 8.4 ZR 28" 500Wh 8G	City and trekking bicycle
20-Q-0025	Futura Sport 8.5 HE 28" 500Wh 8G	City and trekking bicycle
20-Q-0026	Futura Sport 8.5 TR 28" 500Wh 8G	City and trekking bicycle
20-Q-0027	Futura Sport 8.5 ZR 28" 400Wh 8G	City and trekking bicycle
20-Q-0061	Robert/a R7 ZR 26" 500Wh 7G	City and trekking bicycle
20-Q-0062	Robert/a R7 ZR 28" 400Wh 7G	City and trekking bicycle
20-Q-0067	Montfoort Cruise F7 ZR 28" 400Wh 7G	City and trekking bicycle
20-Q-0070	Rob Cross Pro I HE 28" 500Wh 10G	City and trekking bicycle
20-Q-0071	Rob Cross Pro I TR 28" 600Wh 10G	City and trekking bicycle
20-Q-0075	Rob Cross Comp HE 28" 500Wh 9G	City and trekking bicycle
20-Q-0076	Rob Cross Comp TR 28" 500Wh 9G	City and trekking bicycle
20-Q-0077	Rob Cross Sport HE 28" 500Wh 8G	City and trekking bicycle
20-Q-0078	Rob Cross Sport TR 28" 500Wh 8G	City and trekking bicycle
20-Q-0079	Rob Cross Sport ZR 28" 500Wh 8G	City and trekking bicycle
20-Q-0083	Futura Compact R8 ZR 20" 500Wh 8G	Folding bicycle

Table 1: Type number, model and pedelec type

Type no.	Model	Pedelec type
20-Q-0084	Futura Compact R8 ZR 24" 400Wh 8G	Folding bicycle
20-Q-0085	Futura Compact F8 ZR 20" 500Wh 8G	Folding bicycle
20-Q-0086	Futura Compact F8 ZR 24" 400Wh 8G	Folding bicycle
20-Q-0087	Futura Compact 8 ZR 24" 500Wh 8G	Folding bicycle
20-Q-0088	Futura Sport 8.4 ZR 26" 400Wh 8G	City and trekking bicycle
20-Q-0089	Futura Sport 8.5 ZR 26" 500Wh 8G	City and trekking bicycle
20-Q-0091	Rob Cross Comp ZR 28" 500Wh 9G	City and trekking bicycle
20-Q-0092	Robert/a F7 ZR 26" 500Wh 7G	City and trekking bicycle
20-Q-0093	Robert/a F7 ZR 28" 400Wh 7G	City and trekking bicycle
20-Y-0012	Rob Fold R7 FA 20" 400Wh 7G	Folding bicycle
20-Y-0013	Rob Fold F7 FA 20" 400Wh 7G	Folding bicycle

Table 1: Type number, model and pedelec type

1.3 Identifying the operating instructions

You will find the *operating instructions* identification number at the bottom left-hand side of each page. The identification number consists of the document number, the version number and the release date.

Identification number	MY20H01-42_1.0_21.06.2019
-----------------------	---------------------------

Table 2: Identification number

1.4 Laws, standards and directives

The *operating instructions* comply with the essential requirements specified in:

- Machinery Directive 2006/42/EC
- Electromagnetic Compatibility Directive 2014/30/EU
- ISO/DIS 20607:2018 Safety of machinery – Instruction handbook – General drafting principles
- EN 15194:2017 Cycles – Electrically power assisted cycles – pedelec bicycles
- EN 11243:2016, Cycles – Luggage carriers for bicycles – Requirements and test methods
- EN ISO 17100:2016-05, Translation Services – Requirements for translation service.

1.5 Subject to change

The information contained in these *operating instructions* are the approved technical specifications at the time of printing. Any significant changes will be included in a new issue of the *operating instructions*.

You will find any modifications to these *operating instructions*:

<https://www.hercules-bikes.de>.

1.6 Language

The *original operating instructions* are written in German. A translation is not valid without the *original operating instructions*.

1.7 For your safety

The pedelec's safety concept comprises four elements:

- rider and/or operator instruction, and bicycle maintenance and repair by the specialist dealer
- the section on general safety
- the warnings in these *operating instructions*
- the safety markings on the nameplate and the pedelec.

1.7.1 Instruction, training and customer service

The supplying specialist dealer will provide customer service. Contact details can be found on the back page of these *operating instructions* and on the data sheet. If you are unable to contact your specialist dealer, you will find other specialist dealers online at www.hercules-bikes.de.

The rider or the operator of the pedelec will be instructed on the pedelec's functions in person when the supplying specialist dealer hands over the pedelec, if not before. In particular, this instruction will cover the pedelec's electrical functions and correct use of the charger.

Each rider to whom this bicycle is provided must receive instruction on the pedelec's functions. A printed copy of these *operating instructions* must be provided to each rider, who must take note of and observe them.

1.7.2 Basic safety instructions

These *operating instructions* explains all general safety instructions in Section 2.

1.7.3 Warnings

Hazardous situations and actions are marked with warnings. The warnings in these *operating instructions* are indicated as follows:



Will lead to serious or even fatal injuries if ignored. High-risk hazard.



May lead to serious or even fatal injuries if ignored. Medium-risk hazard.



May lead to minor or moderate injuries. Low-risk hazard.



May lead to material damage if ignored.

1.7.4 Safety markings

The following safety markings are used on the pedelec's nameplates:

	General warning
	Adhere to the instructions for use

Table 3: Meaning of safety markings

1.8 For your information

1.8.1 Instructions for actions

Instructions for actions are structured in accordance with the following pattern:

- ✓ Requirements (optional)
- ▶ Instruction for action
- ⇒ Result of the action (optional)

1.8.2 Language conventions

The pedelec described in these *operating instructions* may be equipped with alternative equipment. The pedelec equipment is defined by its respective type number. Where applicable, the word *Alternative* beneath the heading indicates alternatively used components. The following terms are used for better legibility:

Term	Meaning
<i>Operating instructions</i>	Original operating instructions or translation of the original operating instructions
Pedelec	Electric motor driven cycle
Motor	Drive motor

The following conventions are used in these *operating instructions*:

Convention	Use
<i>Italics</i>	Glossary terms
SPACED	Indicators on the <i>display screen</i>
[▷ <i>Example, page numbering</i>]	Cross references
•	Bulleted lists

1.9 Nameplate

The nameplate is situated on the frame. You will find the precise position of the nameplate in Figure 2. You will find thirteen pieces of information on the nameplate.

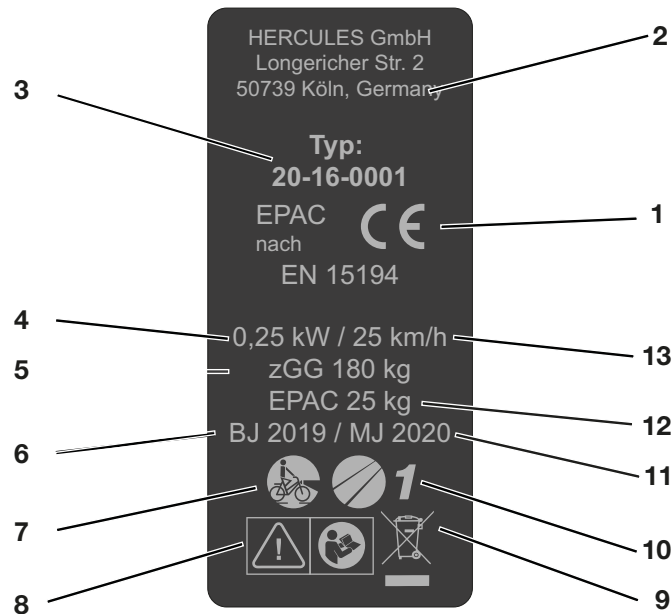

Figure 1: Nameplate, example

No.	Designation	Description
1	CE marking	The manufacturer uses the CE marking to declare that the pedelec complies with applicable requirements.
2	Manufacturer's contact details	You can contact the manufacturer at this address. You can find more information in Section 1.1.
3	Type number	All pedelec models have an eight-digit type number, which is used to specify the design model year, the type of pedelec and the version. You can find further information in Section 1.9.1.
4	Maximum continuous power	The maximum continuous power is the maximum power for the electric motor output shaft during 30 minutes.
5	Permitted total weight	The permitted total weight is the weight of the fully assembled pedelec with the rider and baggage.
6	<i>Year of manufacture</i>	The <i>year of manufacture</i> is the year in which the pedelec was manufactured. The production period is from August 2019 to July 2020.
7	Pedelec type	You can find further information in Section 1.9.3.
8	Safety markings	You can find more information in Section 2.6.
9	Disposal instructions	You can find more information in Section 9.
10	Area of use	You can find further information in Section 1.9.4.
11	Model year	The model year refers to the first production year that the series-manufactured pedelec was produced in the version and is not always identical with the <i>year of manufacture</i> . The <i>year of manufacture</i> may be before the model year in some cases. If no technical modifications are introduced to the series, production may continue of pedelecs from a previous model year.
12	Weight of ready-to-ride pedelec	The indicated weight for a ready-to-ride pedelec refers to the weight of a pedelec at the time of sale. The weight of each additional accessory must be added to this weight.
13	<i>Shut-off speed</i>	Speed reached by the pedelec at the moment when the current has dropped to zero or to the no load current value.

1.9.1 Information on the nameplate

Alongside the warnings, product nameplates also contain other important information about the pedelec:













		Read the instructions
		Separate collection of electrical and electronic devices
		Separate collection of batteries
		Must not be thrown into fire (burning prohibited)
		Battery must not be opened
		Device of protection class II
		Only suitable for use indoors
		Fuse (device fuse)
		EU conformity
		Recyclable material
		Protect from temperatures above 50 °C and direct sunlight

Table 4: Relevance of safety instructions

2 Safety

2.1 General warnings

WARNING

Risk of fire and explosion due to faulty battery

The safety electronics on a damaged or faulty battery may fail. The residual voltage can cause a short circuit. The battery may self-ignite and explode.

- ▶ Remove batteries with external damage from service immediately and never charge them.
- ▶ Only operate the battery and accessories if they are in perfect condition.
- ▶ Only use batteries which are approved for use on your pedelec.
- ▶ Do not use the battery with defective connecting cables or defective contacts.
- ▶ Use the battery with BOSCH Systems pedelecs only. This is the only way that the battery will be protected from dangerous overloading.
- ▶ If the battery becomes deformed or begins to smoke, keep at a safe distance, disconnect the power supply at the socket, and notify the fire service immediately.
- ▶ Never extinguish a damaged battery with water or allow it to come into contact with water.
- ▶ If a battery is dropped or struck but shows no signs of external damage, remove it from service and observe it for at least 24 hours.
- ▶ Faulty batteries are hazardous goods. Dispose of faulty batteries properly and as quickly as possible.
- ▶ Store in a dry place until disposal. Never store in the vicinity of flammable substances.
- ▶ Never open or repair the battery.
- ▶ Charge the battery before use. Only use the charger included in the scope of delivery.

CAUTION

Electric shock in case of damage

Damaged chargers, cables and plug connectors increase the risk of electric shock.

- ▶ Check the charger, cable and plug connector before each use. Never use a damaged charger.

Risk of fire and explosion due to short circuit

Small metal objects may jumper the electrical connections of the battery. The battery may self-ignite and explode.

- ▶ Keep paper clips, screws, coins, keys and other small parts away and do not insert them into the battery.

Risk of fire and explosion due to incorrect charger

Batteries which are recharged with an unsuitable charger may become damaged internally. This may result in fire or an explosion.

- ▶ Only ever use the battery with the supplied charger.
- ▶ Mark the supplied charger clearly to prevent mix-ups – with the pedelec *frame number* or *type number*, for example.

Risk of fire and explosion due to penetration by water

The battery is only protected from simple spray water. Penetration by water can cause a short circuit. The battery may self-ignite and explode.

- ▶ Never immerse the battery in water.
- ▶ If there is reason to believe that water may have entered into the battery, the battery must be removed from service.

CAUTION**Risk of fire and explosion due to high temperatures**

Excessively high temperatures will damage the battery. The battery may self-ignite and explode.

- ▶ Protect the battery against heat.
- ▶ Never expose the battery to sustained direct sunlight.

Fire caused by overheated charger

The charger heats up when charging the battery. In case of insufficient cooling, this can result in fire or burns to the hands.

- ▶ Never use the charger on a highly flammable surface (e.g. paper, carpet etc.).
- ▶ Never cover the charger during the charging process.

Never leave the battery unattended during charging.

Electric shock caused by penetration by water

If water penetrates into the charger, there is a risk of electric shock.

- ▶ Never charge the battery outdoors.

Notice

If you leave a key inserted when riding or transporting the pedelec, it may break off or the locking system may open accidentally.

- ▶ Remove the key from the battery lock immediately after use.
- ▶ We recommend that you attach the key to a key ring.

2.2 Toxic substances**WARNING****Intoxication from suspension oil**

Suspension oil in the rear frame damper is toxic to the touch, irritates respiratory tracts and causes cancer, sterility and mutation in germ cells.

- ▶ Never disassemble the rear frame damper.
- ▶ Never allow suspension oil to come into contact with the skin.

CAUTION**Chemical burns to the skin and eyes caused by faulty battery**

Liquids and vapours may leak from damaged or faulty batteries. They can irritate the airways and cause burns.

- ▶ Avoid contact with leaked liquids.
- ▶ Ventilate with fresh air and consult a doctor if you suffer any pain or discomfort.
- ▶ Immediately consult a doctor in case of contact with the eyes or any discomfort.
- ▶ In case of contact with the skin, rinse off immediately with water.
- ▶ Ventilate the room well.

Hazard for the environment due to leaking brake fluid

The brake system contains a toxic, environmentally harmful brake fluid. Such fluids will contaminate if they enter the sewers or groundwater.

- ▶ The brake system must be repaired immediately if brake fluid leaks out. Contact your specialist dealer about repair.
- ▶ Dispose of leaking brake fluid in an environmentally responsible way in accordance with statutory regulations. Ask a specialist dealer for more information.

Environmental hazard posed by oil and lubricants from the fork

The fork contains toxic, environmentally harmful oils and lubricants. Such fluids will contaminate if they enter the sewers or groundwater.

- ▶ The fork must be repaired immediately if oils and lubricants are leaking out. Contact your specialist dealer about repair.
- ▶ Dispose of leaked oils and lubricants in an environmentally responsible way in accordance with statutory regulations. Ask a specialist dealer for more information.

Environmental hazard posed by oil and lubricants from rear frame damper

The rear frame damper contains toxic and environmentally harmful oils and lubricants. Such fluids will contaminate if they enter the sewers or groundwater.

- ▶ Dispose of oils and lubricants which have leaked from the rear frame damper in an environmentally responsible way in accordance with statutory regulations. Ask a specialist dealer for more information.

2.3 Requirements for the rider

If there are no legal requirements for riders of electrically power-assisted cycles, we recommend that the rider should be a minimum 15 years of age and have experience with muscle-powered bicycles.

The rider's physical and mental abilities must be adequate to use a muscle-powered pedelec.

2.4 Protection for vulnerable groups

You must keep batteries and charger away from children and people with reduced physical, sensory or mental capabilities or lacking in experience and knowledge.

If minors are to use the pedelec, comprehensive instruction should be provided by or in the presence of the legal guardians. Supervised use should also be scheduled until it is certain that the pedelec is being used as per these *operating instructions*.

2.5 Data privacy

During maintenance, the pedelec is connected to the diagnosis tool and data is transferred to Bosch Pedelec Systems (Robert Bosch GmbH) about the use of electric drive components to help improve the product. You will find more information on the Bosch Pedelec website <https://www.bosch-ebike.com/en/>

2.6 Personal protective equipment

We recommend that you wear a suitable cycling helmet. We also recommend that you wear sturdy footwear and typical, close-fitting clothing for bicycles.

2.7 Safety markings and safety instructions

The nameplate contains the following safety markings and safety instructions:



Symbol	Explanation
	General warning
	Adhere to the instructions for use

Table 5: Meaning of safety markings











Symbol	Explanation
	Read the instructions
	Separate collection of electrical and electronic devices
	Separate collection of ordinary and rechargeable batteries
	Must not be thrown into fire (burning prohibited)
	It is forbidden to open any batteries
	Device of protection class II
	Only suitable for use indoors
	Fuse (device fuse)
	EU conformity
	Recyclable material
	Protect from temperatures above 50 °C and direct sunlight

Table 6: Relevance of safety instructions

2.8 Emergency

2.8.1 What to do in an emergency

- ▶ In the event of a hazard or danger in road traffic, apply the brakes on the pedelec until it comes to a halt. The brake acts as an emergency stop system in such cases.

2.8.2 First aid treatment

Symptoms which are caused by combustion gases or leaking fluids require medical attention.

After inhalation

Vapours may emit if the battery is damaged or used improperly. Get into fresh air and consult a doctor if you suffer any pain or discomfort. The vapours may cause respiratory tract irritation.

After skin contact

Remove any solid particles immediately. Rinse the affected area with plenty of water for at least 15 minutes. Then dab the affected skin gently. Do not rub dry. Remove contaminated clothing immediately. Immediately consult a doctor if there is any redness or abnormalities.

After contact with eyes

Rinse eyes with plenty of water for at least 15 minutes. Protect unaffected eye. Seek medical advice immediately.

After swallowing

Drink plenty of milk or water and induce vomiting. Seek medical advice immediately.

2.8.3 Fighting fire

WARNING



Intoxication

Inhaling vapours can cause intoxication.

- ▶ Stand on the side of the fire where the wind is blowing from.
- ▶ Use breathing apparatus if possible.

The safety electronics on a damaged or faulty battery may fail. The residual voltage can cause a short circuit. The battery may self-ignite and explode.

- ▶ Keep your distance if the battery becomes deformed or starts to emit smoke.
- ▶ Evacuate everyone from the immediate area of the fire.
- ▶ Contact the fire service immediately!
- ▶ Use Class fire extinguishers to put out the fire.
- ▶ Never extinguish damaged batteries with water or allow them to come into contact with water.

2.8.4 Leaking fluids

2.8.4.1 Brake fluid

- ▶ The brake system must be repaired immediately if brake fluid leaks out. Contact your specialist dealer about repair.
- ▶ Dispose of leaking brake fluid in an environmentally responsible way in accordance with statutory regulations. Ask a specialist dealer for more information.

2.8.4.2 Oils and lubricants from the fork

- ▶ The brake system must be repaired immediately if brake fluid leaks out. Contact your specialist dealer about repair.
- ▶ Dispose of leaking brake fluid in an environmentally responsible way in accordance with statutory regulations. Ask a specialist dealer for more information.

2.8.4.3 Oils and lubricants from the rear frame damper

- ▶ Dispose of oils and lubricants which have leaked from the rear frame damper in an environmentally responsible way in accordance with statutory regulations. Ask a specialist dealer for more information.



- 1 *Front wheel*
- 2 *Fork*
- 3 *Front guard*
- 4 *Headlight*
- 5 *Handlebars*
- 6 *Stem*
- 7 *Frame*
- 8 *Seat post*
- 9 *Saddle*

- 10 *Pannier rack*
- 11 *Pannier rack battery*
- 12 *Rear light and reflector*
- 13 *Rear guard*
- 14 *Kickstand*
- 15 *Rear wheel*
- 16 *Chain guard casing*
- 17 *Frame number and nameplate*

3.1 Description

3.1.1 Wheel and suspension

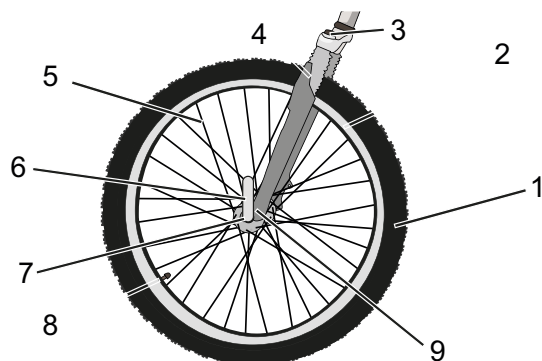

Figure 3: Components of the wheel, example of front wheel

- | | |
|---|---|
| 1 | Tyre |
| 2 | Rim |
| 3 | Suspension fork head with setting wheel |
| 4 | Shock absorber |
| 5 | Spoke |
| 6 | Quick release |
| 7 | Hub |
| 8 | Valve |
| 9 | Fork end of the shock absorber |

3.1.1.1 Valve

Each wheel has a valve. It is used to fill the *tyre* with air. There is a valve cap on each valve. The screw-on valve cap keeps out dust and dirt.

The pedelec either has a conventional *Dunlop valve*, a *Presta valve* or a *Schrader valve*.

3.1.2 Suspension

Both forks and suspension forks are fitted in this model series. A suspension fork is based either on a steel spring or air suspension. Unlike a rigid fork, a suspension fork has two functions which improve floor contact and comfort: suspension and damping.

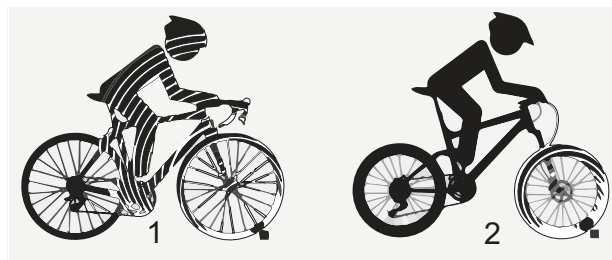

Figure 4: Pedelec without suspension (1) and with suspension (2) when riding over an obstacle

The suspension prevents an impact, such as one caused by a stone lying in the bike's path, from being channelled directly into the rider's body via the fork. The impact is absorbed by the suspension system instead. This causes the suspension fork to compress. The compression can be disabled so that a suspension fork reacts like a rigid fork. The switch to disable the fork is called a remote lockout.

After compressing, the suspension fork returns to its original position. If there is a damper, it decelerates movement, preventing the suspension system from springing back in an uncontrolled manner and stopping the fork from vibrating up and down. Dampers which dampen compressive deflection movements, i.e. a compression load, are called compression dampers or compression dashpots.

Dampers which dampen rebound deflection movements, i.e. a rebound load, are called rebound dampers or dashpots.

3.1.2.1 Steel suspension fork structure

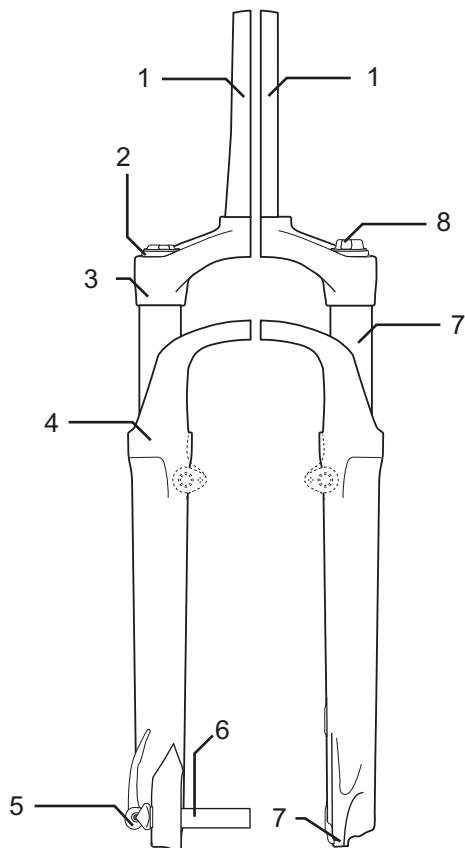

Figure 5: Example showing Suntour fork

The stem and handlebars are fastened to the fork steerer (1). The wheel is fastened to the quick release axle (6). Other elements: the compression setting (2), crown (3), Q-Loc (5), dust seal (6), fork end for quick release (7), stanchion (8) and spring (9)

3.1.2.2 Air suspension fork structure

The pedelec's fork features both air suspension and a compression damper plus a rebound damper in some cases.

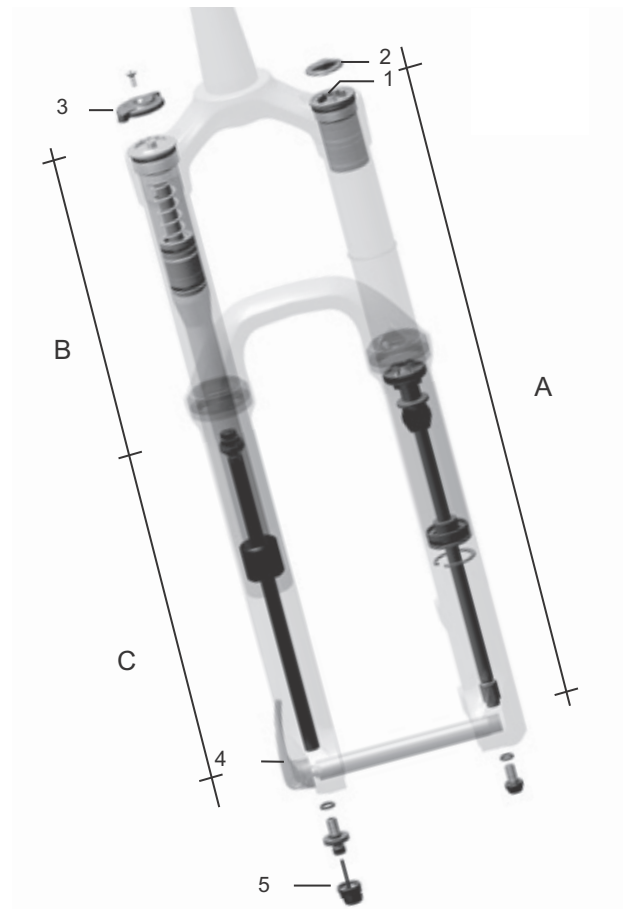

Figure 6: Example showing Yari fork

You can see the following components in the diagram: Air valve (1), valve cap (2) fork lock (3), quick release (4) and rebound damper adjuster (5) and the assembly groups: Air suspension fork (A), compression damper assembly group (B) and rebound damper assembly group (C)

3.1.2.3 Structure of the FOX rear frame damper

The rear frame damper features air suspension, a compression damper and a rebound damper.

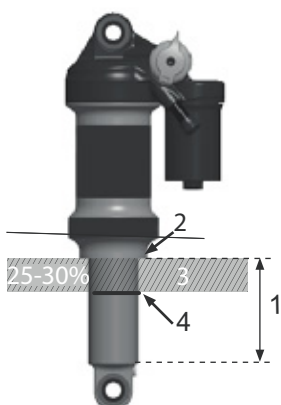

Figure 7: Example showing FOX rear frame damper

- 1 Guide rod eye
- 2 Air valve
- 3 Setting wheel
- 4 Lever
- 5 Air chamber
- 6 O-ring

3.1.2.4 Structure of the Suntour rear frame damper

The rear frame damper features air suspension, a compression damper and a rebound damper.

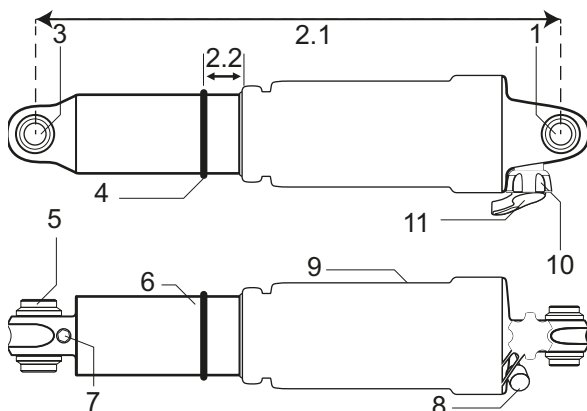

Figure 8: Example showing Suntour rear frame damper

- 1 Upper eye
- 2.1 Total damper length
- 2.2 SAG
- 3 Lower eye
- 4 O-ring
- 5 Sleeve
- 6 Damper unit
- 7 IFP (internal floating piston)
- 8 Air valve
- 9 Air chamber
- 10 Lockout lever
- 11 Rebound lever

3.1.3 Brake system

The pedelec's brake system comprises either a hydraulic:

- rim brake on the front and rear wheels
- disc brake on the front and rear wheels or
- a rim brake on the front and rear wheels and an additional back-pedal brake.

The mechanical brakes are used as an emergency stop system and bring the pedelec to a halt quickly and safely in the event of an emergency.

3.1.3.1 Rim brake

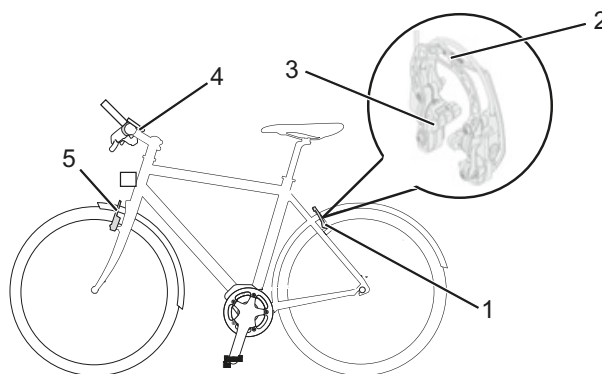

Figure 9: Rim brake components with details; Magura HS22 used as an example

- 1 Rear wheel rim brake
- 2 Brake booster
- 3 Brake lining
- 4 Handlebars with brake lever
- 5 Front wheel rim brake

The rim brake stops the wheel moving when the rider pulls the *brake lever*, causing two brake linings, positioned opposite one another, to be pressed onto the *rims*.

The hydraulic rim brake features a locking lever.

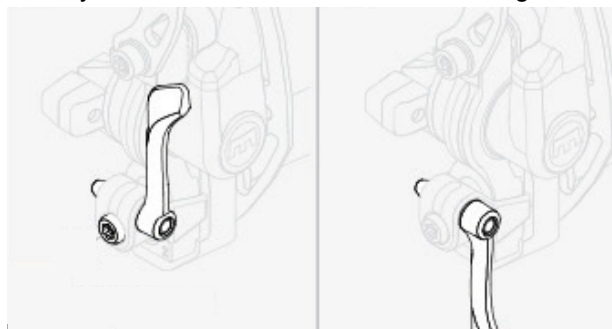

Figure 10: Rim brake locking lever, closed (1) and open (2)

The rim brake locking lever is not marked with any lettering. Only a specialist dealer may set the rim brake locking lever



3.1.3.2 Disc brake

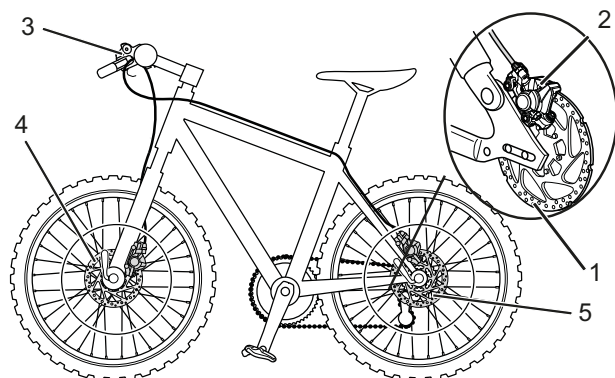

Figure 11: Pedelec brake system with a disc brake – example

- 1 Brake disc
- 2 Brake calliper with brake linings
- 3 *Handlebars with brake lever*
- 4 Front wheel brake disc
- 5 Rear wheel brake disc

On a pedelec with a disc brake, the brake disc is screwed permanently to the wheel *hub*.

The *brake lever* is pulled to increase brake pressure. The brake fluid is used to transfer pressure through the brake lines to the cylinders in the brake calliper. The braking force is boosted by a speed reduction and applied to the brake linings. These apply the brake disc mechanically. If the *brake lever* is pulled, the brake linings are pressed against the brake disc and the wheel movement is decelerated until it comes to a stop.

3.1.3.3 Back-pedal brake



Figure 12: Pedelec brake system with a back-pedal brake – example

- 1 Rear wheel rim brake
- 2 *Handlebars with brake lever*
- 3 Front wheel rim brake
- 4 *Pedal*
- 5 Back-pedal brake

The back-pedal brake stops the movement of the rear wheel when the rider pedals in the opposite direction to the direction of travel.

3.1.3.4 ABS

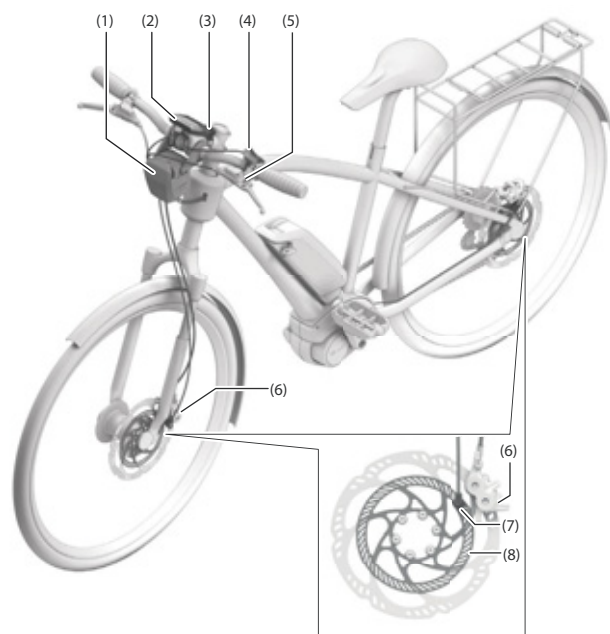

Figure 13: BOSCH ABS

- | | |
|---|-------------------------------|
| 1 | ABS control unit with housing |
| 2 | Display screen |
| 3 | ABS indicator lamp |
| 4 | Control panel |
| 5 | Front wheel brake lever |
| 6 | Brake calliper |
| 7 | Bike speed sensor |
| 8 | Sensor disc |

ABS is an added function in some pedelecs.

The rear wheel brake function does not depend on the anti-blocking system functioning correctly.

When the brakes are applied, the ABS function detects critical slippage thanks to the wheel speed sensors on the front and rear wheels and limits slippage on the front wheel by reducing brake pressure there, thus stabilising the wheel. Once the wheel has been stabilised, the wheel is brought to the blocking limit again by building up pressure selectively.

The lever moves a little more towards the handlebars with each brake impulse during this process. If the wheel blocks again, the pressure is reduced again. This process is repeated to keep the wheel at its limit of traction, thus making optimum use of the coefficient of friction between the tyres and the road surface.

The ABS function terminates when one of the following events occurs:

- The buffer chamber in the ABS control unit is filled completely.
- The pedelec has come to a halt.
- The rider releases the brake.

Besides the ABS function itself, the unit also includes a system to detect when the rear wheel is raised during full braking. This enables the rider to counteract a potential flip-over caused by extremely hard brake manoeuvres to a certain extent.

If the battery level falls below a specified threshold, the system deactivates the power assistance first. The system will still remain active, including the display, lights and ABS until the battery reserve is also used up. The electric drive system and, consequently, the ABS will not switch off until the battery has almost fully discharged.

The indicator lamp lights up for about 5 seconds before the system switches off completely. The ABS indicator lamp will then go out, even though the ABS control system is not available. The ABS is not active if there is no battery on the pedelec or its battery is empty.

The brake system itself remains functional. It is only the anti-blocking system control which no longer operates.

3.1.4 Electric drive system

The pedelec is driven by muscle power applied to the chain drive. The force which is applied by pedalling in the direction of travel drives the front chain wheel. The chain transmits the force onto the rear chain wheel and then onto the rear wheel.

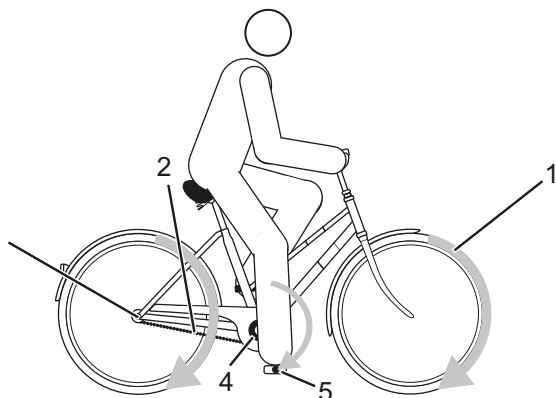

Figure 14: Diagram of mechanical drive system

- 1 Direction of travel
- 2 Chain
- 3 Rear chain wheel
- 4 Front chain wheel
- 5 Pedal

The pedelec also has an integrated electric drive system.

The electric drive system is made up of 8 components:

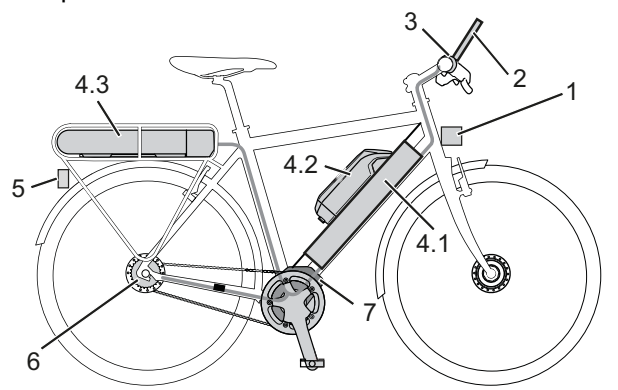

Figure 15: Diagram of electric drive system

- 1 *Headlight*
- 2 *Display*
- 3 *Control panel*
- 4.1 *Integrated rechargeable battery*
- 4.2 *Frame battery and/or*
- 4.3 *Pannier rack battery*

- 5 *Rear light*
 - 6 *Electric gear shift (alternative)*
 - 7 *Motor*
- A charger which is designed for the battery.

As soon as the required muscle power from the rider pedalling passes a certain level, the motor is activated gently and assists the pedalling motion of the rider. The motor force is determined by the set level of assistance.

The pedelec does not have a separate emergency stop or emergency shut-off button. The drive system can be stopped in case of emergency by removing the *display*.

The motor switches off automatically as soon as the rider no longer pedals, the temperature is outside the permitted range, there is an overload or the shut-off speed of 25 km/h has been reached.

A push assist system can be activated. The speed depends on the selected gear. The push assist continues to drive the pedelec as long as the rider presses the push assist button on the *handlebars*. The speed can be a maximum of 6 km/h in this case. The drive stops when the plus button is released.

3.1.5 Rechargeable battery

Bosch rechargeable batteries are lithium ion batteries which are developed and manufactured to the latest technical standards. These batteries meet and exceed applicable industrial safety standards. The battery has an internal electronic protection circuit, which is specifically designed for the charger and the pedelec. The battery temperature is monitored at all times. Each individual cell in a Bosch rechargeable battery is protected by a steel cup and cased in a plastic housing. You must not open this housing. You must also avoid mechanical loads or exposure to intense heat since they may damage the battery cells and cause flammable contents to leak out.

The battery is protected against deep discharge, overcharging, overheating and short circuit. In the event of a hazard, a protective circuit switches the battery off automatically.

The battery has a high energy content when charged. The substances in lithium-ion battery cells may become inflammable under certain

conditions. You will find codes of practice for their safe handling in Section 2 on Safety and Section 6.9 on Rechargeable battery in the operating instructions.

If the electric drive system is not used for about 10 minutes (e.g. the pedelec is stationary) and no button has been pressed on the display or the control panel, the electric drive system and the rechargeable battery are automatically switched off to save energy.

The type and duration of operating conditions have a significant effect on the battery life. Just like any other lithium-ion battery, the Bosch battery will age naturally, even if it is not being used.

Its battery life can be extended if the battery is well maintained and, more importantly, stored at the correct temperatures. The charging capacity will decrease with age, even if the battery is maintained properly. If the operating time is severely shortened after charging, this is a sign that battery has reached the end of its useful life.

Battery performance is reduced when the temperature drops since this increases electrical resistance. As a result, you should expect the range to be shorter than normal in winter. We recommend using thermal protection sleeves when riding longer distances in the cold.

The pedelec features either an integrated battery, a pannier rack battery or a frame battery. Each battery has its own lock.

Three different types of frame batteries can be fitted:

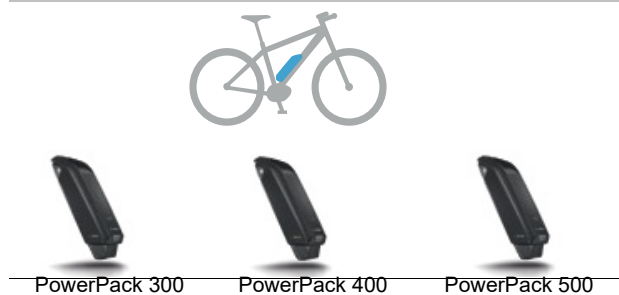

Table 7: Overview of frame batteries

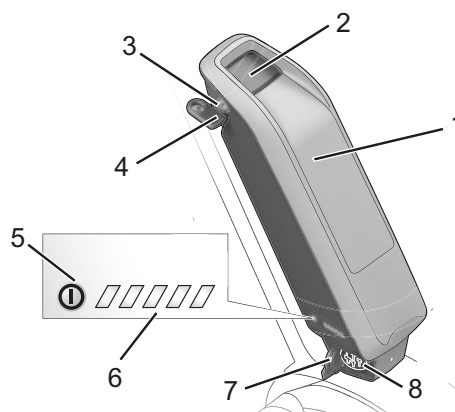

Figure 16: Details of frame battery

- 1 Battery housing
- 2 Battery lock
- 3 Key for the battery lock
- 4 On/off button (battery)
- 5 Battery level indicator
- 6 Charging port cover
- 7 Port for charger plug

3.1.5.1 Pannier rack battery

Three different types of pannier rack batteries can be fitted:

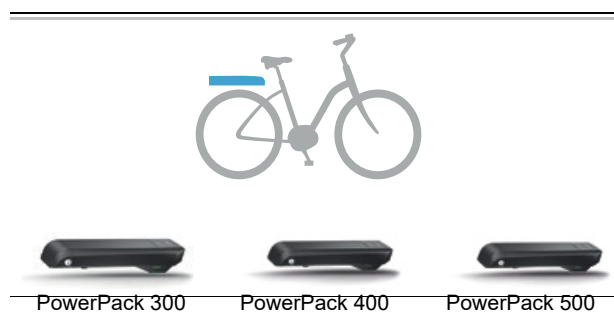

Table 8: Overview of pannier rack batteries

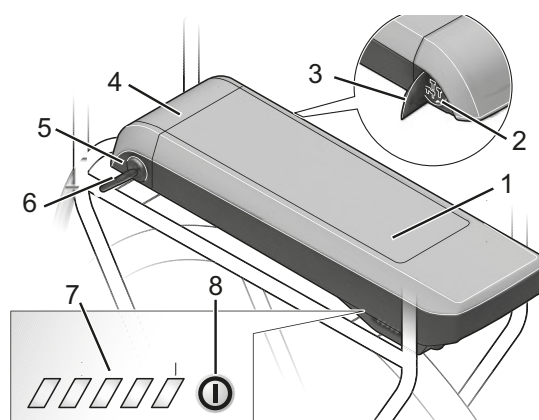

Figure 17: Details of pannier rack battery

- 1 Battery housing
- 2 Charging port for charger plug
- 3 Charging port cover
- 4 Battery lock
- 5 Key for the battery lock
- 6 *Battery level indicator*
- 7 On-Off button (battery)

3.1.5.2 Integrated battery

Two different types of pannier rack batteries can be fitted:

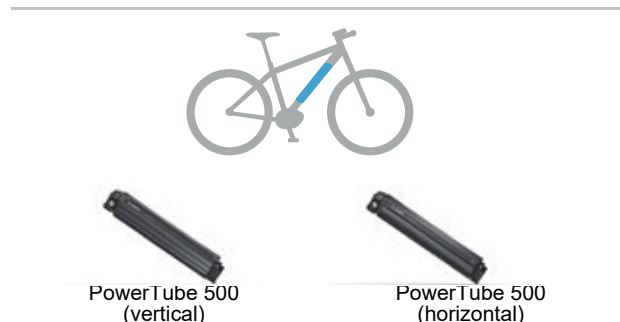

Table 9: Overview of integrated batteries

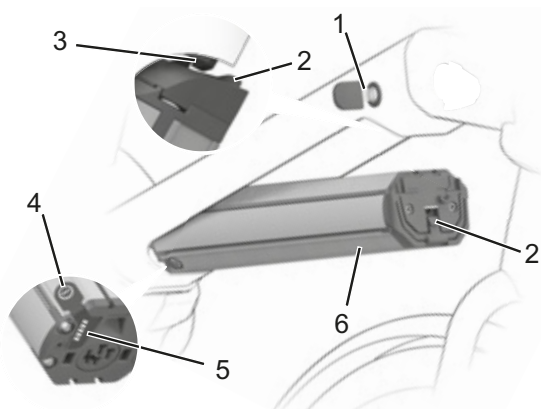

Figure 18: Details of integrated bat

- 1 Key for the battery lock
- 2 Retainer guard
- 3 Securing hook
- 4 On-Off button (battery)
- 5 *Battery level indicator*
- 6 Integrated rechargeable battery housing

3.1.6 Control panel with display

The *control panel with display* uses four operating elements to control the drive system and shows journey data.

The pedelec battery powers the *control panel with display*. The *control panel with display* also has two internal non-rechargeable button cell batteries. This ensures that the system can be switched on using the *control panel with display*.

Internal button cell batteries, type CR2016	3 V, 90 mAh
Type	CR2016
Storage temperature	-10 °C to +60 °C

Table 10: Technical data for battery of the control panel with display

The pane of glass on the display may steam up from the inside in the event of abrupt temperature fluctuations. This is not a malfunction.

The *control panel with display* has four buttons.

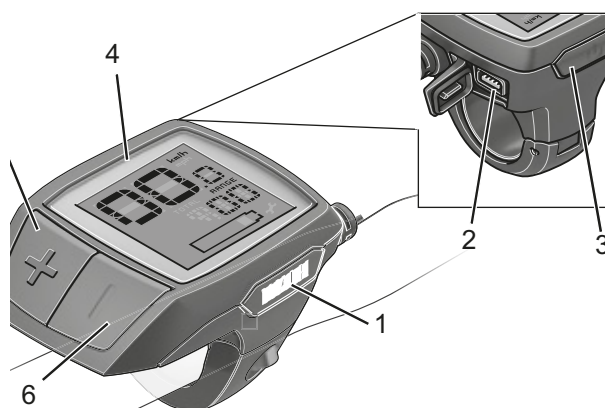

Figure 19: Overview of the control panel with display

Symbol	Designation
1	WALK Push assist button
2	USB port
3	On-Off button
4	Screen display
5	+ Plus button
6	- Minus button

Table 11: Overview of the control panel with display

3.1.7 Riding light

When the riding light is activated, the *headlight* and the rear light are switched on together.

3.1.8 Charger

Each pedelec is supplied with a charger. As a general rule, any BOSCH charger may be used:

- The 2A compact charger
- The 4A standard charger
- The 6A fast charger

Observe the operating instructions in the section on Documents.

3.2 Proper use

The pedelec must only be used in perfect, fully functional condition. National requirements may apply to the pedelec which the standard equipment may not meet. For riding on public roads, some special regulations apply in relation to the *riding light*, *reflectors* and other components.

The general laws and the regulations for the prevention of accidents and environmental protection in the respective country of use must be adhered to. All check lists and instructions for actions in these *operating instructions* met. Approved accessories can be installed by specialist staff.

Each pedelec is assigned a *pedelec type*, which determines its proper use and area of use.







City and trekking bicycles	Child s bicycles/ bicycles for young adults	Mountain bikes	Racing bicycle	Cargo bike	Folding bicycle
					
<p>City and trekking bicycles are designed for daily, comfortable use. They are suitable for riding on public roads.</p>	<p>The legal guardians of minor riders must read and understand these <i>operating instructions</i> before commissioning.</p> <p>The contents of these <i>operating instructions</i> must be communicated to the riders in an age-appropriate manner.</p> <p>The cycles for children and young adults are suitable for riding on public roads. The size of the pedelec must be checked regularly for orthopaedic reasons.</p> <p>A check must be made at least every three months to make sure that the permitted total weight is being observed.</p>	<p>Mountain bikes are designed for sports use. The design characteristics include a short wheelbase, a sitting position with the rider inclined towards the front, and a brake requiring low actuation force.</p> <p>Mountain bikes are a piece of sports equipment. Users require an adaptation period and must be physical fit to use them. Use requires the appropriate training; in particular riding in bends and braking should be practised.</p> <p>The strain on the rider, in particular the hands and wrists, arms, shoulders, neck and back, is accordingly high. Inexperienced riders tend to brake excessively and lose control as a result.</p>	<p>A racing bicycle is designed for fast rides on roads and paths with a good, undamaged road surface.</p> <p>A racing bicycle is a piece of sporting equipment and not a means of transport. A racing bicycle is characterised by its lightweight structure and a design which is stripped to the minimum parts required for riding.</p> <p>The frame geometry and the layout of the operating elements are designed in such a way that the bicycle can be ridden at high speeds. The frame design requires practice to ensure the ride is able to ride slowly, apply the brakes and get on and off the bike safely.</p> <p>The sitting position is athletic. The strain on the rider, in particular the hands and wrists, arms, shoulders, neck and back, is accordingly high. The sitting position therefore requires physical fitness.</p>	<p>The cargo bike is suitable for daily transportation of loads on public roads.</p> <p>The transportation of loads requires skill and physical fitness in order to balance the additional weight. The very varied loading conditions and weight distributions require special practice and skill when braking and riding in bends.</p> <p>A longer period is required to adaptation to the length, width and turning circle. The cargo bike requires cautious riding. You must pay attention to the traffic on public roads and the condition of the route accordingly.</p>	<p>The folding bicycle is suitable for use on public roads.</p> <p>A folding bicycle can be folded up and is thus suitable for space-saving transportation, for example on public transport or in a car.</p> <p>The folding function of the folding bicycle makes it necessary to use smaller wheels and longer brake cables and Bowden cables. Therefore, in case of an increased load, a reduction in riding stability and braking power, diminished comfort and reduced durability are to be expected.</p>

Table 12: Proper use

3.3 Improper use

Failure to adhere to the proper use poses a risk of personal injury and material damage. The pedelec is not suitable for the following uses:

- when the electrical drive has been manipulated
- riding with a damaged or incomplete pedelec
- riding over steps
- riding through deep water
- lending the pedelec to untrained riders
- carrying other people
- riding with excessive baggage
- riding with no hands
- riding on ice and snow
- improper servicing
- improper repair
- tough areas of use, such as professional competitions
- stunt riding or acrobatics.

City and trekking bicycles	Child s bicycles/ bicycles for young adults	Mountain bikes	Racing bicycle	Cargo bike	Folding bicycle
					
City and trekking bicycles are not sports bicycles. If used for sports, the rider can expect reduced riding stability and diminished comfort	Cycles for children and young adults are not toys.	Mountain bikes must be retrofitted with lighting, a guard and other fittings as specified by national laws and regulations before they are used on public roads.	The folding bicycle is not a sports bicycle.	A folding bicycle is not a touring bicycle or a sports bicycle.	Racing bikes must be retrofitted with lighting, a guard and other fittings as specified by national laws and regulations before they are used on public roads.

Table 13: Information on incorrect use

3.4 Technical data

3.4.1 Pedelec

Transportation temperature	5 °C - 25 °C
Ideal transportation temperature	10 °C - 15 °C
Storage temperature	10 °C - 30 °C
Ideal storage temperature	10 °C - 15 °C
Operating temperature	5 °C - 35 °C
<i>Work environment</i> temperature	15 °C - 25 °C
Charging temperature	0 °C - 40 °C
Power output/system	250 W (0.25 kW)
Shut-off speed	25 km/h

Table 14: Pedelec technical data

3.4.2 ActiveLine motor

Continuous power rating	250 W
Max. torque	40 Nm
Nominal voltage	36 V DC
Protection class	IP54
Weight about	3 kg
Operating temperature	-5 °C - +40 °C
Storage temperature	-10 °C - +50 °C

Table 15: ActiveLine motor technical data

3.4.3 ActiveLine Plus motor

Continuous power rating	250 W
Max. torque	50 Nm
Nominal voltage	36 V DC
Protection class	IP54
Weight about	3.3 kg
Operating temperature	-5 °C - +40 °C
Storage temperature	-10 °C - +50 °C

Table 16: ActiveLine Plus motor technical data

3.4.4 Performance Line Cruise motor

Continuous power rating	250 W
Max. torque	63 Nm
Nominal voltage	36 V DC
Protection class	IP54
Weight	4 kg
Operating temperature	-5 - +40 °C
Storage temperature	-10 - +50 °C

Table 17: Performance Line Cruise motor technical data

3.4.5 Performance Line Speed motor

Continuous power rating	250 W
Max. torque	63 Nm
Nominal voltage	36 V DC
Protection class	IP54
Weight	4 kg
Operating temperature	-5 °C - +40 °C
Storage temperature	-10 °C - +50 °C

Table 18: Performance Line Speed motor technical data

3.4.6 Performance Line CX motor

Continuous power rating	250 W
Max. torque	75 Nm
Nominal voltage	36 V DC
Protection class	IP54
Weight	4 kg
Operating temperature	-5 °C - +40 °C
Storage temperature	-10 °C - +50 °C

Table 19: Performance Line CX motor technical data

3.4.7 Lighting

Applicable to motors: Performance Line Cruise, Performance Line Speed and Performance Line CX

Voltage about	6/12 V
Maximum output	
Front light	8.4/17.4 W
Rear light	0.6/ 0.6 W

Applicable to motors: ActiveLine and ActivLine Plus

Voltage about	12 V
Maximum output	
Front light	17.4 W
Rear light	0.6 W

Table 20: Lighting technical data

3.4.8 PowerPack 300 battery

Nominal voltage	36 V
Nominal capacity	8.2 Ah
Energy	300 Wh
Weight	2.5/ 2.6 kg
Protection class	IP54
Operating temperature	-5 °C - +40 °C
Storage temperature	-10 °C - +60 °C
Permitted charging temperature range	0 °C – + 40 °C

Table 21: PowerPack 300 battery technical data

3.4.9 PowerPack 400 battery

Nominal voltage	36 V
Nominal capacity	11 Ah
Energy	400 Wh
Weight	2.5/ 2.6 kg
Protection class	IP54
Operating temperature	-5 °C - +40 °C
Storage temperature	-10 °C - +60 °C
Permitted charging temperature range	0 °C – + 40 °C

Table 22: PowerPack 400 battery technical data

3.4.10 PowerPack 500 battery

Nominal voltage	36 V
Nominal capacity	13.4 Ah
Energy	500 Wh
Weight	2.6/ 2.7 kg
Protection class	IP54
Operating temperature	-5 °C - +40 °C
Storage temperature	-10 °C - +60 °C
Permitted charging temperature range	0 °C – + 40 °C

Table 23: PowerPack 500 battery technical data

3.4.11 PowerTube battery

Nominal voltage	36 V
Nominal capacity	13.54 Ah
Energy	500 Wh
Weight	2.8 kg
Protection class	IP54
Operating temperature	-5 °C - +40 °C
Storage temperature	-10 °C - +60 °C
Permitted charging temperature range	0 °C – + 40 °C

Table 24: PowerTube battery technical data

3.4.12 Purion display

Internal lithium ion battery	2 × 3 V CR2016
Operating temperature	-5 °C - +40 °C
Storage temperature	-10 °C - +50 °C
Charging temperature	0 °C – + 40 °C
Protection rating (with USB cover closed)	IP54
Weight about	0.1 kg

Table 25: Purion display technical data

3.4.13 USB port

Charge voltage	5 V
Charging current	Max. 500 mA

Table 26: USB port technical data

3.4.14 BOSCH Pedelec ABS BAS100

Operating temperature	-5 °C - +40 °C
Storage temperature	-10 °C - +60 °C
Protection class	IPx7
Weight about	1 kg

Table 27: BOSCH Pedelec ABS BAS100 technical data

3.4.15 Emissions

A-weighted emission sound pressure level	< 70 dB(A)
Total vibration level for the hands and arms	< 2.5 m/s ²
Highest effective value of weighted acceleration for the entire body	< 0.5 m/s ²

Table 28: Emissions from the pedelec*

*The safety requirements as per Electromagnetic Compatibility Directive 2014/30/EU have been met. The pedelec and the charger can be used in residential areas without restriction.

3.4.16 Tightening torque

Axle nut tightening torque	35 Nm - 40 Nm
Handlebars clamping screw maximum tightening torque*	5 Nm - 7 Nm

Table 29: Tightening torque values

*if there is no other data on the component

3.5 Environmental requirements

You can be ride the pedelec within a temperature range between 5 °C and 35 °C. The drive system is limited in its performance outside this temperature range.

Optimal operating temperature	5 °C - 35 °C
--------------------------------------	--------------

We recommend that you don't insert a battery charged and stored at room temperature into the pedelec until just before setting off. We recommend using thermal protection sleeves when riding longer distances in the cold.

As a general rule, you should avoid temperatures under -10 °C or over +60 °C

You must also keep within the following temperature ranges:

Transportation temperature	-10 °C - 50 °C
Storage temperature	-10 °C - 50 °C
Charging temperature	
<i>Work environment</i> temperature	15 °C - 25 °C
Charging temperature	0 °C - 40 °C

Table 30: Pedelec technical data

The nameplate contains symbols for the pedelec's area of use. Check what roads and paths you may use before you ride the pedelec for the first time.



























Area of use	City and trekking bicycles	Child s bicycles/ bicycles for young adults	Mountain bikes	Racing bicycle	Cargo bike	Folding bicycle
 1	 Suitable for tarmacked and paved roads.	 Suitable for tarmacked and paved roads.		 Suitable for tarmacked and paved roads.	 Suitable for tarmacked and paved roads.	 Suitable for tarmacked and paved roads.
 2	 Suitable for tarmacked roads, cycle paths and firm gravel paths and roads, and longer sections with moderate slopes and jumps up to 15 cm.	 Suitable for tarmacked roads, cycle paths and firm gravel paths and roads, and longer sections with moderate slopes and jumps up to 15 cm.	 Suitable for tarmacked roads, cycle paths and easy to demanding off-road riding, sections with moderate slopes and jumps up to 61 cm.	 Suitable for tarmacked roads, cycle paths and firm gravel paths and roads, and longer sections with moderate slopes and jumps up to 15 cm.		
 3			 Suitable for tarmacked roads, cycle paths and easy to demanding off-road riding, limited downhill use and jumps up to 122 cm.			
 4			 Suitable for tarmacked roads, cycle paths and easy to extremely difficult off-road riding, unlimited downhill use and any jumps			

Table 31: Area of use

The pedelec is unsuitable for the following areas of use:

Area of use	City and trekking bicycles	Child s bicycles/ bicycles for young adults	Mountain bikes	Racing bicycle	Cargo bike	Folding bicycle	
 1	 Never drive off-road or perform jumps.	 Never drive off-road or perform jumps.		 Never drive off-road or perform jumps.	 Never drive off-road or perform jumps.	 Never drive off-road or perform jumps.	
 2	Never drive off-road or perform jumps over 15 cm.	Never drive off-road or perform jumps over 15 cm.	Never drive off-road or perform jumps over 15 cm.	Never drive off-road or perform jumps over 15 cm.			
 3			Never ride downhill or perform jumps over 61 cm.				
 4			Never traverse extremely difficult off-road terrain or perform jumps over 122 cm.				

3.6 Description of controls and screens

3.6.1 Handlebars

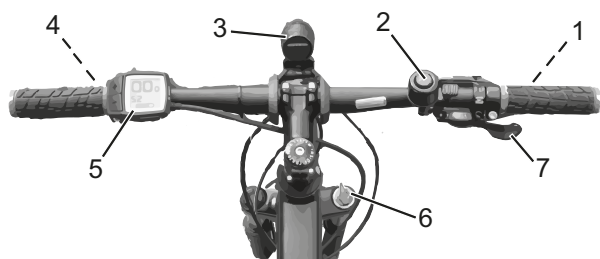

Figure 20: Detailed view of pedelec from rider position, example

- 1 Rear brake lever
- 2 Bell
- 3 Headlight
- 4 Display
- 5 Front brake lever
- 6 Control panel
- 8 Fork lock on the suspension fork
- 9 Shifter

3.6.2 Battery level indicator

Each battery has its own level indicator:

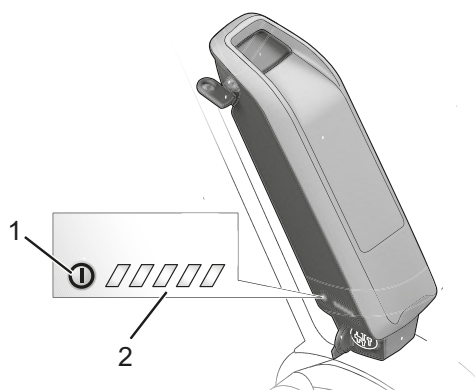

Figure 21: Example of a battery level indicator

- 1 On-off button (battery)
- 2 Battery level indicator

The five green LEDs on the battery level indicator show the charge level when the battery is switched on. Each LED represents about 20% of battery capacity. All five LEDs will light up when the battery is fully charged. The charge level for the activated battery is also shown on the *display screen*.

If the battery level falls below 5%, all the LEDs on the operating status and battery level indicator will go out. However, the battery level is still shown on the *display screen*.

3.6.3 Control panel on-screen indicators

The *control panel with display* has seven on-screen indicators:

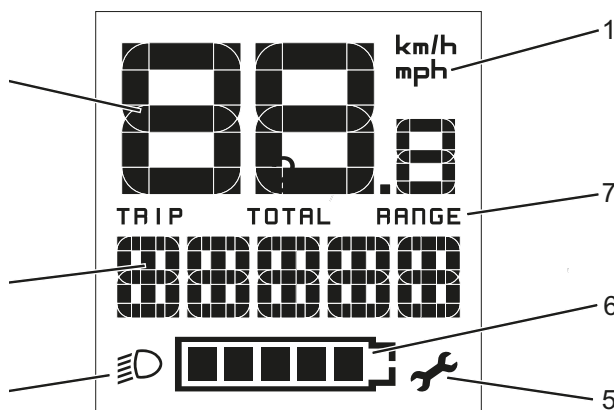

Figure 22: On-screen indicators overview

Use	
1	Unit of measure for speed
2	Tachometer screen
3	Function display
4	Riding light symbol
5	Service symbol
6	Battery level indicator
7	Level of assistance

Table 32: On-screen indicators overview

3.6.3.1 Unit of measure for speed

The speed can be displayed in km/h or mph. You can select whether the speed is displayed in kilometres or miles in the system settings.

3.6.3.2 Tachometer screen

The tachometer shows the current speed at all times.

3.6.3.3 Function display

The last setting is always displayed on the function display screen by default.

The *control panel with display* shows one of three items of journey information. The displayed item of journey information can be switched

Screen display	Function
TRIP	Distance travelled since the last RESET
TOTAL	Display of the total distance travelled (cannot be changed)
RANGE	Estimated range of the available battery charge, calculated based on the most recent manner of riding

Table 33: Journey information

System data

To view all the information on the system being used and the software, the rider has to call up the *system data*.

Screen display	Function
SEARIAL NUMBER DU	Drive system serial number
SEARIAL NUMBER HMI	Serial number for control panel with display
SW VERSION HMI	Software version of the control panel with display
SW VERSION DU	Drive system software version
SW VERSION PP	Battery software version

Table 34: System data, not changeable

System message

The drive system monitors itself continuously and if an error is detected, it is indicated by a system message. The system may switch off automatically depending on the type of error. There is a table of system messages in the appendix

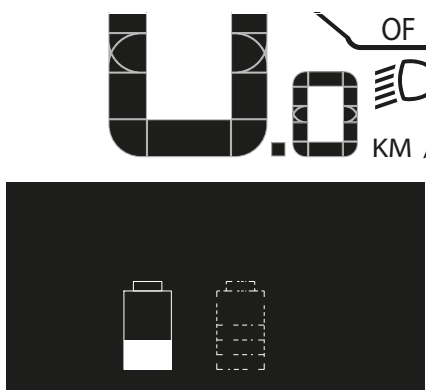

Figure 23: The left battery is currently being charged

3.6.3.4 Gear recommendation

Pedalling frequencies higher than 50 revolutions per minute optimise drive unit efficiency. However, very slow pedalling uses up a great deal of energy. You can increase the speed and range while applying the same force by selecting the right gear. It is therefore best to follow gear recommendations.

The gear recommendation function reacts to excessively slow or excessively quick pedalling and recommends a change of gear.

- ✓ The gear recommendation function has to be switched on in the system settings.

▲	Pedalling frequency is too high, a higher gear is recommended
▼	Pedalling frequency is too low, a lower gear is recommended

Table 35: Symbols of the gear recommendation function

3.6.3.5 Tachometer screen

The tachometer shows the current speed at all times.

You can select whether the speed is displayed in kilometres or miles in the system settings.

3.6.3.6 Function display

The function display shows texts and readings. Three different types of information are shown:

- Journey information
- System settings and data, and
- System messages.

Journey information

Depending on the type of pedelec, the function display may show up to seven journey information items. The displayed journey information can be switched.

CLOCK	Current time
MAX. SPEED	Maximum speed reached since the last RESET
AVG. SPEED	Average speed reached since the last RESET
TRIP TIME	Journey time since last RESET
RANGE	Estimated range of the available battery charge
ODOMETER	Display of the total distance travelled (cannot be changed)
TRIP DISTANCE	Distance travelled since the last RESET

Table 36: Journey information

Additional journey information

Applies only to Pedelecs with eShift with Shimano DI2 automatic hub gears

The following additional functions are available on the function display:

Screen display	Change
AUTO: ON/AUTO: OFF	This menu option indicates whether the automatic mode is switched on or off

Table 37: Additional journey information

Applies only to Pedelecs with eShift with manual Shimano DI2 automatic hub gears

The following additional functions are available on the function display:

Screen display	Change
GEAR	The current gear shift is shown on the display screen. The new gear is shown briefly on the screen each time it is changed.

Table 38: Additional journey information

Applies only to Pedelecs with eShift with Shimano DI2 automatic hub gears

The following additional functions are available on the function display:

Screen display	Change
GEAR	The current gear shift is shown on the display screen. The new gear is shown briefly on the screen each time it is changed.

Table 39: Additional journey information

Applies only to Pedelecs with eShift with NuVinci H|Sync/ envoilo with Optimized H|Sync

The following additional functions are available on the function display:

Screen display	Change
± NUVINCI CADENCE / ± NUVINCI GEAR	The current gear shift is shown on the display screen. The new gear is shown briefly on the screen each time it is changed. The standard setting is ± NuVinci cadence.

Table 40: Changing the system settings

Applies only to Pedelecs with eShift with Rohloff E-14 Speedhub 500/14

The following additional functions are available on the function display:

	Change
GEAR	The current gear shift is shown on the display screen. The new gear is shown briefly on the screen each time it is changed.

Table 41: Changing the system settings

System settings and data

In order to see the system settings and data, the rider has to call up the system settings. The rider can change the values of the system settings, but not the system data.

Screen display	Function
- CLOCK +	Changing the time
- WHEEL CIRCUM +	Value of the wheel circumference in mm
- ENGLISH +	Changes the language
- UNIT KM/MI +	Selects whether the speed and distance are displayed in kilometres or miles
- TIME FORMAT +	Select whether the time is displayed in 12-hour clock or 24-hour clock format
- SHIFT RECOM. OFF +	Switches the gear recommendation on and off

Table 42: Changeable system settings

Screen display	Function
POWER ON HOURS	Display of the total journey duration
DISPL. VX.X.X.X	Display software version
DU VX.X.X.X	Drive system software version
DU# XXXX XXXXX	Drive system serial number
SERVICE MM/YYYY	(Alternative) defined inspection date
SERV. XX KM/MI	(Alternative) defined inspection
BAT. VX.X.X.X	Software version
1.BAT VX.X.X.X	Software version
2.BAT VX.X.X.X	Software version

Table 43: System data, not changeable

Additional system settings

Applies only to Pedelecs with eShift with Shimano DI2 automatic hub gears

Screen display	Change
- Start gear +	This is where you can set the start gear. The automatic gear switch function is switched off in Position --. This menu option is only shown when the on-board computer is positioned in its mount.
Gear adjustment	You can use this menu option to make a fine adjustment to the Shimano DI2. You'll find the specified setting range in the gear manufacturer's operating instructions. Make the fine adjustment as soon as you hear any unusual noises from the gear shift. This menu option is only shown when the on-board computer is positioned in its mount.
Gear vx.x.x.x:	this is the gear software version. This menu option is only shown when the on-board computer is positioned in its mount. This menu option is only shown if you have an electronic control gear.

Table 44: Changing the system settings

Applies only to Pedelecs with eShift with manual Shimano DI2 automatic hub gears.

Screen display	Change
– Start gear +	This is where you can set the start gear. The automatic gear switch function is switched off in Position – –. This menu option is only shown when the on-board computer is positioned in its mount.
Gear adjustment	You can use this menu option to make a fine adjustment to the Shimano DI2. You'll find the specified setting range in the gear manufacturer's operating instructions. Make the fine adjustment as soon as you hear any unusual noises from the gear shift. This menu option is only shown when the on-board computer is positioned in its mount.
Gear vx.x.x.x:	this is the gear software version. This menu option is only shown when the on-board computer is positioned in its mount. This menu option is only shown if you have an electronic control gear.

Table 45: Changing the system settings

Applies only to Pedelecs with eShift with Shimano DI2 automatic hub gears.

Screen display	Change
Gear adjustment	You can use this menu option to make a fine adjustment to the Shimano DI2. You'll find the specified setting range in the gear manufacturer's operating instructions. Make the fine adjustment as soon as you hear any unusual noises from the gear shift. This menu option is only shown when the on-board computer is positioned in its mount.
Gear recovery	You can use this menu option to reset the rear derailleur if it has been detached – due to a crash or impact against the derailleur. You will find a description of how to reset the gear shift in the gear shift manufacturer's operating instructions. This menu option is only shown when the on-board computer is positioned in its mount.
Gear vx.x.x.x:	this is the gear software version. This menu option is only shown when the on-board computer is positioned in its mount. This menu option is only shown if you have an electronic control gear.

Table 46: Changing the system settings

Applies only to Pedelecs with eShift with NuVinci H|Sync/ enviolo with Optimized H|Sync

Screen display	Change
Gear calibration	This is where you can perform a calibration on the stepless gear. Press on the Lighting button to confirm calibration. Then follow the instructions. You also might need to perform a calibration while riding in the event of a fault. In such cases, you also press on the Lighting button to confirm calibration and then follow the instructions on the display. This menu option is only shown when the on-board computer is positioned in its mount
Gear vx.x.x.x:	this is the gear software version. This menu option is only shown when the on-board computer is positioned in its mount. This menu option is only shown if you have an electronic control gear.

Table 47: Changing the system settings

Applies only to Pedelecs with eShift with Rohloff E-14 Speedhub 500/14

Screen display	Change
Start gear	This is where you can set the start gear. The automatic gear switch function is switched off in Position – –. This menu option is only shown when the on-board computer is positioned in its mount.
Gear vx.x.x.x:	this is the gear software version. This menu option is only shown when the on-board computer is positioned in its mount. This menu option is only shown if you have an electronic control gear.

Table 48: Changing the system settings

3.6.4 System message

The drive system monitors itself continuously and if an error is detected, it is indicated by a system message. The system may switch off automatically depending on the type of error. You will find assistance for system messages in 8.5 *First aid*. There is a table of system messages in the Appendix.

3.6.5 ABS indicator lamp

The anti-blocking system indicator lamp must light up after the system has started up and must go out once speed has reached about 5 km/h. If the ABS indicator lamp does not light up when the electric drive system starts, the ABS is defective. An error code on the display also tells the rider that it is defective.

If the indicator lamp does not go out after you set off or it lights up while you are riding, this means there is an error in the anti-blocking system. The anti-blocking system is then no longer active. The brake system itself remains functional. It is only the anti-blocking system control which no longer operates.

If the ABS indicator lamp is lit, the ABS function is not active.

Notice

The anti-blocking system indicator lamp may light up if the front and rear wheels are rotating at widely different speeds from one another – for example, if the rider cycles on the rear wheel only or if a wheel is rotating for a unusually long time without making contact with the ground (fitting stand). The anti-blocking system switches off in such cases.

Note: You need to stop and restart the pedelec (switch off and on again) to reactivate the anti-blocking system.

4 Transporting and storing



4.1 Physical transport characteristics

4.1.1 Dimensions during transportation

There was no information relating to the box dimensions at the time of going to press. You'll find the information in the latest *operating instructions* on the retailer portal.

4.1.2 Transport weight

There was no information relating to the box dimensions at the time of going to press. You'll find the information in the latest *operating instructions* on the retailer portal.

4.1.3 Designated handles/lifting points

There was no information relating to the box dimensions at the time of going to press. You'll find the information in the latest *operating instructions* on the retailer portal.

4.2 Transporting



Crash caused by unintentional activation

There is a risk of injury if the drive system is activated unintentionally.

- ▶ Remove the battery before the pedelec is transported.

Risk of fire and explosion due to high temperatures

Excessively high temperatures will damage the battery. Batteries may self-ignite and explode.

- ▶ Never expose batteries to sustained direct sunlight.



Oil leak if no transport securing device

The brake securing device prevents the brakes from being applied accidentally during transportation. This could cause irreparable damage to the brake system or an oil leak, which will harm the environment.

- ▶ Never pull the *brake lever* when the wheel has been dismantled.
- ▶ Always use the transport securing system when transporting dismantled wheels.

Notice

Oil and grease may leak from the pedelec if it is lying flat.

If the shipping box with a pedelec is lying flat or standing on one end, it does not provide the *frame* and wheels with adequate protection against damage.

- ▶ Transport the pedelec in an upright position only.

Bicycle rack systems which use the *handlebars* or *frame* to hold the pedelec in an upside-down position exert inadmissible forces on its components during transportation. This can cause the supporting parts to break.

- ▶ Never use bicycle rack systems which use the pedelec's *handlebars* or *frame* to hold it in an upside-down position.
- ▶ Take into account the weight of the ready-to-use pedelec when transporting it.
- ▶ Remove the *display screen* and the batteries before transporting the pedelec.
- ▶ Protect the electrical components and connections on the pedelec from the weather conditions with suitable protective covers.
- ▶ Remove accessories such as drinking bottles before transporting the pedelec.
- ▶ You must use a suitable bicycle rack system when transporting by car.

Notice

The specialist dealer will advise you on how to select a suitable rack system properly and how to use it safely.

- ▶ If you ship the pedelec, we recommend that you have it partially dismantled and packaged properly by the specialist dealer.
- ▶ Transport the pedelec in a dry, clean position where it is protected from direct sunlight.

4.2.1 Transporting the battery

Batteries are subject to hazardous goods regulations. Undamaged batteries may be transported by private persons in road traffic.

Commercial transport requires compliance with regulations concerning packaging, labelling and the transportation of hazardous goods. Open contacts must be covered and the battery securely packaged.

4.2.2 Shipping the battery

The battery is considered a hazardous good and only trained persons may pack and ship a battery. Contact your specialist dealer regarding any battery shipment.

4.2.3 Using the brake transport securing system

- ▶ Insert the transport securing devices between the brake linings.
- ⇒ The transport securing device is squeezed between the two linings.

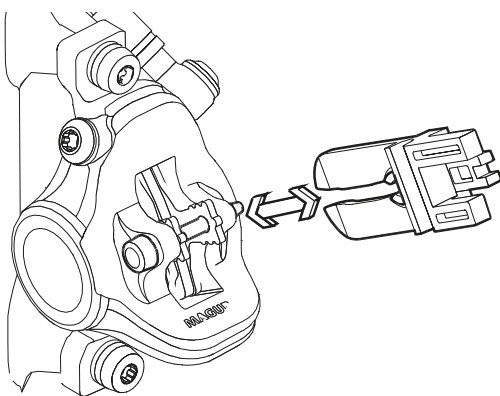

Figure 24: Fastening the transport securing device

4.3 Storing

CAUTION

Risk of fire and explosion due to high temperatures

Temperatures over 60 °C can also cause liquid to leak from the battery and the battery will become damaged. Batteries may self-ignite and explode.

- ▶ Protect batteries against heat.
- ▶ Never store in proximity to hot or flammable objects.
- ▶ Never expose batteries to continuous direct sunlight and never store near heaters.

Notice

Oil and grease may leak from the pedelec if it is lying flat.

If the shipping box with a pedelec is lying flat or standing on one end, it does not provide the *frame* and wheels with adequate protection against damage.

- ▶ Store the pedelec in an upright position only.
- ✓ If the pedelec features a hydraulic seat post, fix only the lower seat post or the frame into a fitting stand to prevent damage to the upper seat post and the seat post lever.
- ✓ Never place a pedelec with a hydraulic seat post upside down on the floor; otherwise you, will damage the seat post lever.
- ✓ Store the pedelec, battery and charger in a dry, clean location.

Optimum pedelec storage temperature	20 °C
Optimum battery storage temperature	22 °C - 26 °C

Table 49: Storage temperature for batteries, the pedelec and charger

- ✓ Temperatures under -10 °C or over +60 °C
Storage at about 20 °C is beneficial to a long service life.

4.3.1 Break in operation

Notice

The battery discharges when not in use. This can cause irreparable damage to the battery.

- ▶ The battery must be recharged every 6 months.

The battery may become damaged if it is connected permanently to the charger.

- ▶ Never connect the battery to the charger permanently.

The display battery discharges when it is not in use. This can cause it to be irreparably damaged.

- ▶ Recharge the display battery for at least 1 hour every 3 months.

If the pedelec is to be removed from service for longer than four weeks, for the winter, for example, you need to prepare it for a break in operation.

4.3.1.1 Preparing a break in operation

- ✓ Remove battery from the pedelec.
- ✓ Charge battery to around 30%–60%
- ✓ The pedelec needs to be cleaned with a damp cloth and preserved with wax spray. Never wax the friction surfaces of the brake.
- ✓ Before longer periods without use, it is recommendable to have your specialist dealer carry out servicing and basic cleaning and apply preservative agent.

4.3.1.2 Taking out of operation

- ▶ Store the pedelec, battery and charger in a dry, clean environment. We recommend storing them in uninhabited rooms with smoke alarms. Dry locations with an ambient temperature of about 20 °C are ideal.
- ▶ Recharge the display battery for at least 1 hour every 3 months.
- ▶ Check the battery level after 6 months. If only one LED on the battery level indicator lights up, recharge the battery to around 30% - 60%.



5 Assembly

WARNING

Injury to the eyes

Problems may arise if the settings are not made to components properly and you may sustain serious injuries as a result.

- ▶ Always wear safety glasses to protect your eyes during assembly.

CAUTION

Crushing caused by unintentional activation

There is a risk of injury if the drive system is activated unintentionally.

- ▶ Remove the battery if it is not absolutely necessary for assembly

- ✓ Assemble the pedelec in a clean, dry environment.

The *work environment* temperature should be between 15 °C and 25 °C.

Work environment temperature	15 °C - 25 °C
------------------------------	---------------

Table 50: Work environment temperature

- ✓ If a fitting stand is used, it must be approved for a maximum weight of 30 kg.
- ✓ We recommend that you always disconnect the battery from the pedelec when using the fitting stand to reduce weight.

5.1 Required tools

The following tools are required to assemble the pedelec:

- Knife
- Hexagon socket spanner 2 (2.5 mm, 3 mm, 4 mm, 5 mm, 6 mm and 8 mm)
- Torque wrench with working range between 5 and 40 Nm
- Twelve-point square socket T25
- Ring spanner (8 mm, 9 mm, 10 mm, 13 mm, 14 mm and 15 mm) and
- Cross, flat head and ordinary screwdriver.

5.2 Unpacking

CAUTION

Hand injuries caused by cardboard packaging

The shipping carton is closed with metal staples. There is a risk of puncture wounds and cuts when unpacking and crushing the packaging.

- ▶ Wear suitable hand protection.
- ▶ Remove the metal staples with pliers before the shipping carton is opened.

The packaging material consists mainly of cardboard and plastic film.

- ▶ The packaging has to be disposed of in accordance with the regulations of the authorities.

5.2.1 Scope of delivery

The pedelec was completely assembled in the factory for test purposes and then dismantled for transportation.

The pedelec is 95–98% pre-assembled. The scope of delivery includes:

- the pre-assembled pedelec
- the front wheel
- the pedals
- quick release (optional)
- the charger
- the *operating instructions*.

The battery is supplied separately from the pedelec.

5.3 Commissioning

CAUTION

Risk of fire and explosion due to incorrect charger

Batteries which are recharged with an unsuitable charger may become damaged internally. This may result in fire or an explosion.

- ▶ Only ever use the battery with the supplied charger.
- ▶ Mark the supplied charger clearly to prevent mix-ups – with the pedelec *frame number* or *type number*, for example.

Burns from hot drive

The drive cooler can become extremely hot during use. Contact may cause burns.

- ▶ Leave the drive unit to cool before cleaning.

Only trained specialist staff may perform initial commissioning since initial commissioning of the pedelec requires special tools and specialist knowledge.

Experience has shown that a pedelec which has not yet been sold is automatically handed to end users as soon as it appears ready to ride.

- ▶ For this reason, every pedelec must be prepared, so that it is fully ready for use immediately after being assembled.
- ▶ All assembly work described in the assembly report (see appendix) must be performed to ensure the pedelec is ready to ride. It describes all safety-relevant inspections, tests and maintenance tasks for the pedelec in a separate list.
- ▶ Complete an assembly report for quality assurance purposes.

5.3.1 Checking the battery

WARNING

Risk of fire and explosion due to faulty battery

The safety electronics may fail if the battery is damaged or faulty. The residual voltage can cause a short circuit. The battery may self-ignite and explode.

- ▶ Never charge a faulty battery.

The battery must be checked before it is charged for the first time.

- ▶ Press the *On-Off button (battery)*.
- ⇒ If none of the LEDs on the battery level indicator light up, the battery may be damaged.
- ⇒ The battery may be fully charged if at least one, but not all, of the LEDs on the battery level indicator is lit up.
- ▶ Once the battery has been charged, insert it into the pedelec.

5.3.2 Installing the wheel in the Suntour fork

Only applies to pedelecs with this equipment

5.3.2.1 Installing the wheel with screw-on axle (15 mm)

- ▶ Insert the axle completely on the drive side.

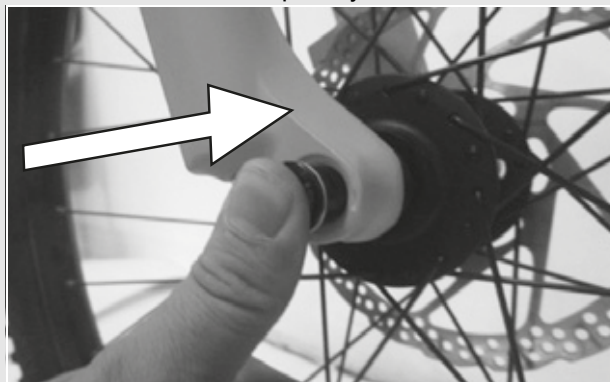

Figure 25: Fully inserting the axle

- ▶ Tighten the axle with a 5 mm hexagon socket spanner to 8–10 Nm.

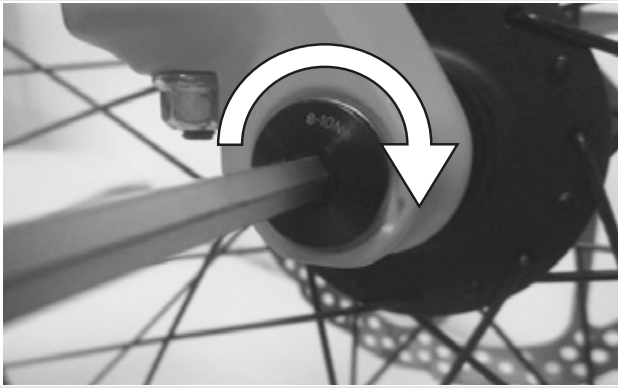

Figure 26: Tightening the axle

- ▶ Insert the securing screw on the non-drive side.



Figure 27: Pushing the quick release lever into the axle

- ▶ Tighten the securing screw with a 5 mm hexagon socket spanner to 5–6 Nm.

⇒ The lever is mounted.



Figure 28: Tightening the securing screw

5.3.2.2 Installing the wheel with screw-on axle (20 mm)

- ▶ Insert the axle completely on the drive side.

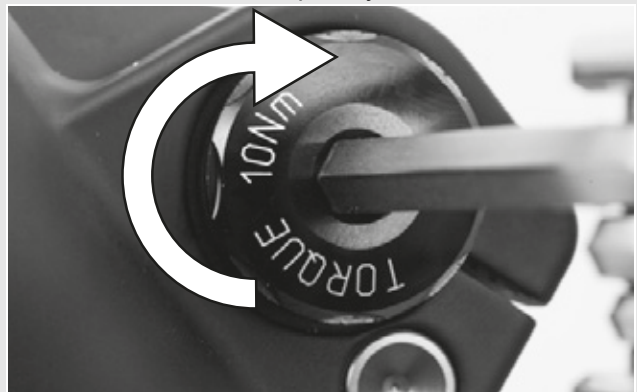

Figure 29: Tightening the inserted axle

- ▶ Tighten the securing clip with a 4 mm hexagon socket spanner to 7 Nm.



Figure 30: Tightening the axle

5.3.2.3 Installing the wheel with a quick release axle

CAUTION

Crash caused by loose quick release axle

A faulty or incorrectly installed quick release axle may become caught in the brake disc and block the wheel. This will cause a crash.

- ▶ Never fit a defective quick release axle.

Crash caused by faulty or incorrectly installed quick release axle

The brake disc becomes very hot during operation. Parts of the quick release axle may become damaged as a result. The quick release axle becomes loose. This will cause a crash with injuries.

- ▶ The quick release axle and the brake disc must be opposite one another.

CAUTION

Crash caused by incorrectly set quick release axle

Insufficient clamping force will cause a detrimental transmission of force. The suspension fork or the quick release axle may break. This will cause a crash with injuries.

- ▶ Never fasten a quick release axle with a tool, such as a hammer or pliers.

- ▶ Insert the axle into the hub on the drive side. Clamping version II.

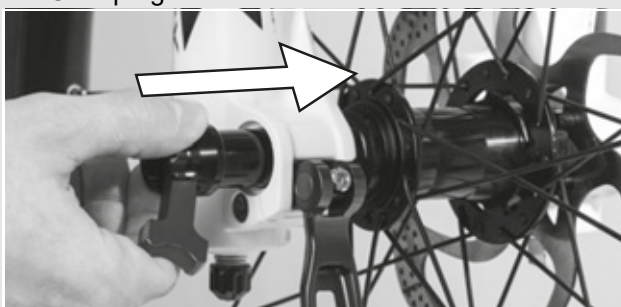

Figure 31: Pushing the axle into the hub

- ▶ Tighten the axle with the red handle.

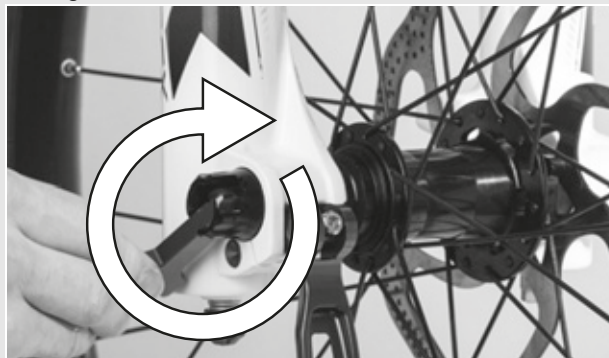

Figure 32: Tightening the axle

- ▶ Push the quick release lever into the axle.

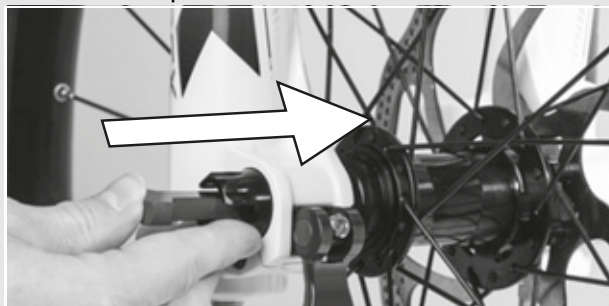

Figure 33: Pushing the quick release lever into the axle

- ▶ Reverse the quick release lever.

⇒ The lever is secured.



Figure 34: Securing the lever

- ▶ Check the position and clamping force of the quick release lever. The quick release lever must be flush with the lower housing. You must be able to see a slight impression on the palm of your hand when you close the quick release lever.



Figure 35: Perfect position for the clamping lever

- ▶ Use a 4 mm hexagon socket spanner to adjust the clamping lever clamping force if required. Afterwards, check the quick release lever position and clamping force.

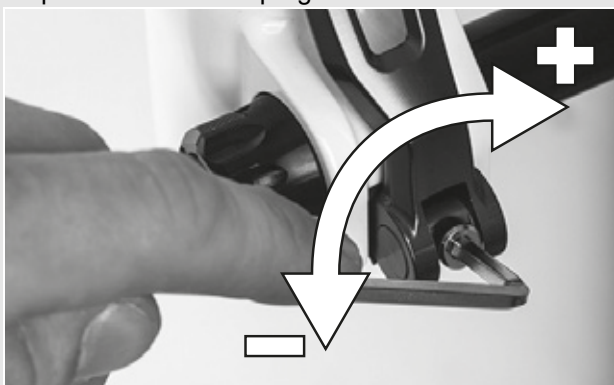

Figure 36: Adjusting the quick release clamping force

5.3.3 Installing the wheel with a quick release

CAUTION

Crash caused by unfastened quick release

A faulty or incorrectly installed quick release may become caught in the brake disc and block the wheel. This will cause a crash.

- ▶ Never fit a defective quick release.

Crash caused by faulty or incorrectly installed quick release

The brake disc becomes very hot during operation. Parts of the quick release may become damaged as a result. The quick release comes loose. This will cause a crash with injuries.

- ▶ The front wheel quick release lever and the brake disc must be situated on opposite sides.

Crash caused by incorrectly set clamping force

Excessively high clamping force will damage the quick release and cause it to lose its function.

Insufficient clamping force will cause a detrimental transmission of force. The suspension fork or the quick release may break. This will cause a crash with injuries.

- ▶ Never fasten a quick release using a tool (e.g. hammer or pliers).
- ▶ Only use the clamping lever with the specified set clamping force.

- ▶ Before installing, ensure that the quick release flange is extended. Open the lever completely.

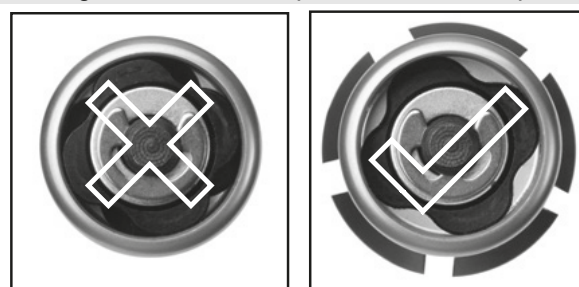

Figure 37: Open and closed flange

- ▶ Push in the quick release until you hear a clicking sound. Make sure that the flange is extended.



Figure 38: Pushing the quick release in

- ▶ Adjust the clamping with a half-open clamping lever until the flange reaches the fork end.

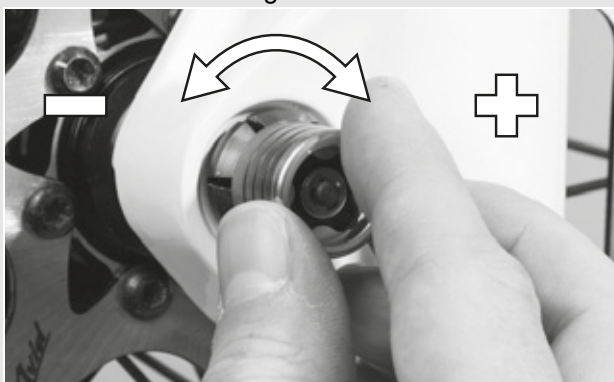

Figure 39: Adjusting the clamping

- ▶ Fully close the quick release. Check the quick release to ensure it is firmly in place and adjust on the flange if necessary.

⇒ The lever is secured.



Figure 40: Closing the quick release

5.3.4 Installing the wheel in the FOX fork

Only applies to pedelecs with this equipment

5.3.4.1 Wheel with quick release (15 mm)

The procedure for installing the 15 x 100 mm and 15 x 110 mm quick releases is the same.

- ▶ Place the front wheel in the fork ends of the fork. Push the axle through the fork end on the non-drive side and hub.

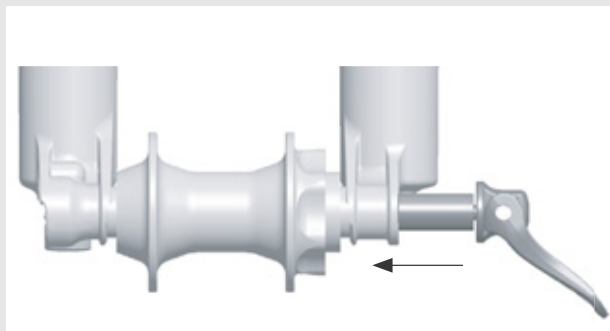

Figure 41: Pushing the quick release in

- ▶ Open the axle lever.
- ▶ Turn the axle five to six complete revolutions clockwise into the axle nut.
- ▶ Close the quick release lever. The lever must be tensioned to the point that it leaves a mark on your hand.
- ▶ The lever must be 1 to 20 mm ahead of the fork leg in the closed position.

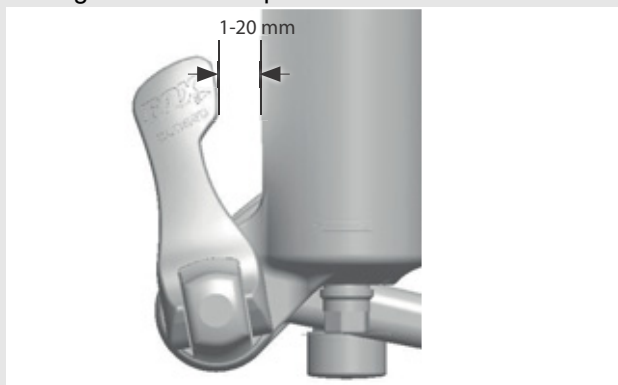

Figure 42: Spacing between lever and fork leg

- ⇒ If the lever is tensioned too little or too much when closed in the recommended position (1 to 20 mm ahead of the fork), the quick release must be adjusted.

5.3.4.2 Adjusting the FOX quick release

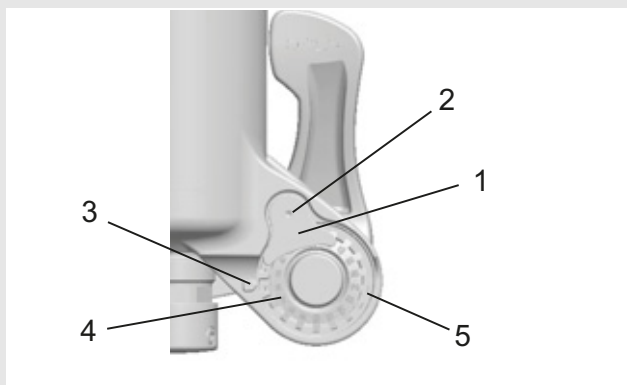

Figure 43: Structure of quick release from rear with (1) axle nut lock, (2) axle nut securing screw, (3) directional arrow, (4) axle setting value and (5) axle nut

- ▶ Record the axle setting value (4) indicated by the directional arrow (3).
- ▶ Loosen the axle nut securing screw (2) with a 2.5 mm hex key by approx. four revolutions, but do not remove the screw completely.
- ▶ Turn the quick release lever to the open position and loosen the axle by approx. four revolutions.
- ▶ Press the axle inward from the side of the open lever. This pushes out the axle nut securing screw so that you can turn it out of the way.
- ▶ Push the axle further forward and turn the axle nut clockwise to increase the lever tension or anti-clockwise to reduce the lever tension.
- ▶ Reinsert the axle nut lock and tighten the screw to 0.9 Nm (8 in-lb).
- ▶ Repeat the steps for installing the axle to check proper installation and correct adjustment.

5.3.4.3 Installing the wheel with Kabolt axles

The procedure for installing the 15 x 100 mm and 15 x 110 mm Kabolt axles is the same.

- ▶ Place the front wheel in the fork ends of the fork. Push the Kabolt axle through the fork end on the non-drive side and hub.

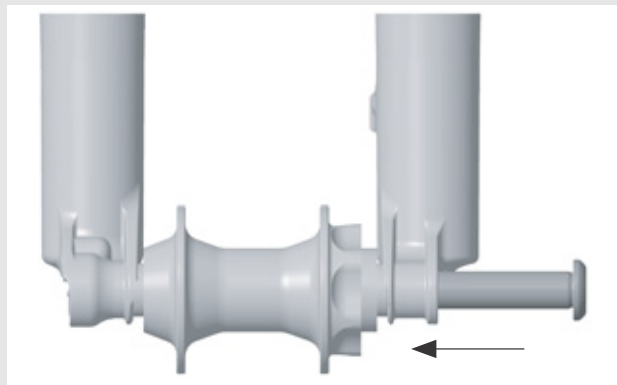

Figure 44: Pushing the Kabolt axle in

- ▶ Tighten the Kabolt axle screw to 17 Nm (150 in-lb) with a 6 mm hex key.

5.3.4.4 Checking the stem and handlebars

Checking connections

- ▶ Stand in front of the pedelec to check whether the handlebars, stem and fork steerer are firmly attached to one another. Clamp the front wheel between your legs. Grasp the handlebar grips. Try to twist the handlebars towards the front wheel.
- ⇒ The stem must not move or twist.

Firm hold

- ▶ Place your entire body weight on the handlebars with the quick release lever closed to check that the stem is firmly in place.
- ⇒ The handlebars shaft must not move downwards in the fork steerer.
- ▶ If the handlebars shaft should move in the fork steerer, increase the quick release lever tensioning. To do so, turn the knurled nut slightly in a clockwise direction with the quick release lever open.
- ▶ Close the lever and check the stem is firmly in position.

Checking the headset backlash

- ▶ To check the handlebar headset backlash, close the quick release lever on the stem. Place the fingers of one hand on the upper headset cup, pull the front wheel brake with the other hand and try to push the pedelec backwards and forwards.
- ▶ The headset cup halves must not move towards one another while you are doing this. Note that there may be noticeable backlash due to worn-out bearing bushes or brake lining backlash in suspension forks and disc brakes.
- ▶ If there is headset backlash in the steering headset, you must adjust it as soon as possible; otherwise, the headset will become damaged. You must make the adjustment as described in the stem manual.

5.3.5 Pedelec sale

- ▶ Complete the data sheet on the *operating instructions* envelope.
- ▶ Note down the key manufacturer and its number.
- ▶ Adjust the pedelec to the rider.
- ▶ Set the *stand* and the *shifter*, and show the purchaser the settings.
- ▶ Instruct the operator or rider on how to use all the pedelec's functions.

6 Operation

6.1 Risks and hazards



WARNING

Injuries and death caused by other road users

Other road users, trucks, cars or pedestrians often underestimate the speed of pedelecs. Likewise, other road users frequently do not see pedelec riders. This may cause a crash with serious injuries or even death.

- ▶ Wear a cycling helmet and high-visibility, reflective clothing.
- ▶ Always take a defensive approach to riding.
- ▶ Avoid the blind spots of vehicles turning off and reduce your speed as a precaution when other road users turn right.

Injuries and death caused by riding incorrectly

A pedelec is not a bicycle. Incorrect riding and underestimated speeds soon result in hazardous situations. This may cause a fall with serious injuries or even death.

- ▶ If you haven't ridden on a pedelec for some time, get accustomed to the speed before you ride at speeds over 12 km/h. Increase the level of assistance on your pedelec gradually.
- ▶ Practice hard braking on a regular basis.
- ▶ Take and complete a riding safety course.



CAUTION

Crash caused by loose clothing

Shoe laces, scarves and other loose items may become entangled in the spokes on the *wheels* and on the *chain drive*. This may cause a crash with injuries.

- ▶ Wear sturdy footwear and close-fitting clothing.



CAUTION

Risk of fire and burning due to hot motor

The motor housing becomes hot when riding. Touching it may cause burns to the skin or other objects.

- ▶ Never touch the motor housing directly after riding.
- ▶ Never place the pedelec on a flammable surface, such as grass or wood, directly after use.

Crash caused by soiling

Heavy soiling can impair pedelec functions, such as braking. This may cause a crash with injuries.

- ▶ Remove coarse soiling before riding.

Crash caused by poor road conditions

Loose objects, such as branches and twigs, may become caught in the wheels and cause a crash with injuries.

- ▶ Be aware of the road conditions.

Ride slowly and brake in good time.

Notice

Heat or direct sunlight can cause the *tyre pressure* to increase above the permitted maximum pressure. This can destroy the *tyres*.

- ▶ Never park the pedelec in the sun.
- ▶ On hot days, regularly check the *tyre pressure* and adjust it as necessary.

When riding downhill, high speeds may be reached.

The pedelec is only designed to exceed a speed of 25 km/h for short periods. The *tyres* in particular can fail if exposed to a continuous load.

- ▶ Decelerate the pedelec with the brakes if you reach speeds greater than 25 km/h.

Notice

Moisture penetrating at low temperatures may impair individual pedelec functions due to the open structural design.

- ▶ Always keep the pedelec dry and free from frost.
- ▶ If the pedelec is to be used at temperatures below 3 °C, the specialist dealer must carry out an inspection and prepare the pedelec for winter usage first.

If you leave a key inserted when riding or transporting the pedelec, it may break off or the locking system may open accidentally.

- ▶ Remove the key from the battery lock immediately after use.
- ▶ We recommend that you attach the key to a key ring.

Off-road riding subjects the joints in the arms to severe strain.

- ▶ Take a break from riding every 30 to 90 minutes, depending on the road surface conditions
-

6.1.1 Tips for a greater range

How far can a pedelec actually travel? There is no simple answer to this question as range depends on many influencing factors. A single battery charge may only last fewer than 20 kilometres but much more than 100 is also possible. There are a few tips which will help you maximize the range.

Cadence

Peddalling frequencies higher than 50 revolutions per minute optimise drive unit efficiency. However, very slow pedalling uses up a great deal of energy.

Weight

Weight should be minimised. The total weight of the pedelec and baggage should not be unnecessarily high.

Stopping & starting

Stopping and starting all the time is less economical than long stretches at the same speed, just like with a car.

Gear shift

Shifting gears correctly also makes pedelecs more efficient: It is best to set off and ride up hills using a low gear and switch up a gear depending on the speed and terrain. The on-board computer provides gear shift recommendations.

Tyre pressure

Rolling resistance can be minimised if tyres are inflated to the right pressure. Tip: Use the maximum permitted tyre pressure to optimize your range.

Motor power indicator

Keep an eye on the motor power indicator on the display screen and adjust your riding accordingly. A long bar indicates high power consumption.

Battery & temperature

Battery performance is reduced as the temperature drops since this increases electrical resistance. As a result, you should expect the range to be shorter than normal in winter.

6.1.2 Personal protective equipment

We recommend that you wear a suitable cycling helmet. We also recommend that you wear sturdy footwear and typical, close-fitting, reflective cycling clothing.

6.2 Error messages

6.2.1 Error message display

The drive system monitors itself continuously and displays a number as an error message if a known error is detected. The system may switch off automatically depending on the type of error.

Code	Description	Method of resolution
410	One or more display buttons are blocked	▶ Check whether buttons are jammed because dirt has got into them, for example. Clean the buttons if they need cleaning.
414	Connection problem with the control panel	▶ Have ports and connections checked.
418	One or more buttons on the control panel are blocked	▶ Check whether buttons are jammed because dirt has got into them, for example. Clean the buttons if they need cleaning.
419	Configuration error	▶ Re-start the system. Contact your specialist dealer if the problem persists.
422	Connection problem with the drive unit	▶ Have ports and connections checked.
423	Connection problem	▶ Have ports and connections checked.
424	Communication error with components communicating with one another	▶ Have ports and connections checked.
426	Internal time-out error	▶ Re-start the system. Contact your specialist dealer if the problem persists. It is not possible to display or adjust the tyre size in the basic settings menu in this error status.
430	Internal display battery flat	▶ Recharge internal display battery (while in its mount or using USB port).
431	Software version error	▶ Re-start the system. Contact your specialist dealer if the problem persists.
440	Internal drive unit error	▶ Re-start the system. Contact your specialist dealer if the problem persists.
450	Internal software error	▶ Re-start the system. Contact your specialist dealer if the problem persists.
460	Error in USB port	▶ Re-start the system. Contact your specialist dealer if the problem persists.

Table 51: List of error messages

Code	Description	Method of resolution
490	Internal display error	▶ Have display checked.
502	Fault in the lighting	▶ Check the light and its cabling. ▶ Re-start the system. ▶ Contact your specialist dealer if the problem persists.
504	System response to detected tuning, Sas Pedelec switches to emergency ride mode and logs the error	▶ Can be reset for 90 minutes by riding (possible 3 times) ▶ If the error occurs again, the specialist dealer will need to set up the system again.
503	Speed sensor error	▶ Re-start the system. ▶ Contact your specialist dealer if the problem persists.
510	Internal sensor error	▶ Re-start the system. Contact your specialist dealer if the problem persists.
511	Internal drive unit error	▶ Re-start the system. Contact your specialist dealer if the problem persists.
530	Battery error	▶ Turn off the drive system. ▶ Remove the battery. ▶ Insert the battery again. ▶ Re-start the system. ▶ Contact your specialist dealer if the problem persists.
531	Configuration error	▶ Re-start the system. Contact your specialist dealer if the problem persists.
540	Temperature error	▶ The pedelec is outside the permitted temperature range. ▶ Switch the pedelec off to cool the drive unit down or warm it up to the permitted temperature range. ▶ Re-start the system. ▶ Contact your specialist dealer if the problem persists.
550	An inadmissible electrical load has been detected	▶ Remove the electrical load. ▶ Re-start the system. ▶ Contact your specialist dealer if the problem persists.
580	Software version error	▶ Re-start the system. Contact your specialist dealer if the problem persists.

Table 51: List of error messages

Code	Description	Method of resolution
591	Authentication error	<ul style="list-style-type: none"> ▶ Turn off the drive system. ▶ Remove the battery. ▶ Insert the battery again. ▶ Re-start the system. ▶ Contact your specialist dealer if the problem persists.
592	Incompatible component	<ul style="list-style-type: none"> ▶ Insert a compatible display. ▶ Re-start the system. ▶ Contact your specialist dealer if the problem persists.
593	Configuration error	<ul style="list-style-type: none"> ▶ Re-start the system. ▶ Contact your specialist dealer if the problem persists.
595, 596	Communication error	<ul style="list-style-type: none"> ▶ Check the cabling to the gears. ▶ Re-start the system. ▶ Contact your specialist dealer if the problem persists.
602	Internal error during charging	<ul style="list-style-type: none"> ▶ Disconnect the charger from the battery. ▶ Re-start the system. ▶ Plug the charger into the battery. ▶ Contact your specialist dealer if the problem persists.
603	Internal fault	<ul style="list-style-type: none"> ▶ Re-start the system. ▶ Contact your specialist dealer if the problem persists.
605	Temperature error	<ul style="list-style-type: none"> ▶ The pedelec is outside the permitted temperature range. ▶ Switch the system off to cool the drive unit down or warm it up to the permitted temperature range. ▶ Re-start the system. ▶ Contact your specialist dealer if the problem persists.
605	Temperature error during the charging process	<ul style="list-style-type: none"> ▶ Disconnect the charger from the battery. ▶ Leave the battery to cool. ▶ Contact your specialist dealer if the problem persists.
606	External fault	<ul style="list-style-type: none"> ▶ Check the cabling. ▶ Re-start the system. ▶ Contact your specialist dealer if the problem persists.
610	Voltage error	<ul style="list-style-type: none"> ▶ Re-start the system. ▶ Contact your specialist dealer if the problem persists.

Table 51: List of error messages

Code	Description	Method of resolution
620	Charger error	<ul style="list-style-type: none"> ▶ Replace the charger. ▶ Contact your specialist dealer if the problem persists.
640	Internal fault	<ul style="list-style-type: none"> ▶ Re-start the system. ▶ Contact your specialist dealer if the problem persists.
655	Multiple battery error	<ul style="list-style-type: none"> ▶ Turn off the system. ▶ Remove the battery. ▶ Insert the battery again. ▶ Re-start the system. ▶ Contact your specialist dealer if the problem persists.
656	Software version error	<ul style="list-style-type: none"> ▶ Contact your specialist dealer to install a software update.
7xx	Gear error	<ul style="list-style-type: none"> ▶ Please observe the manufacturer's operating instructions.
800	Internal ABS error	<ul style="list-style-type: none"> ▶ Contact your specialist dealer.
810	Implausible signals from the wheel speed sensor	<ul style="list-style-type: none"> ▶ Contact your specialist dealer.
820	Error in the line to the front wheel speed sensor	<ul style="list-style-type: none"> ▶ Contact your specialist dealer.
821 ... 826	Implausible signals from the front wheel speed sensor. Sensor disc possibly missing, defective or incorrectly installed; significantly different tyre diameter between the front wheel and rear wheel; extreme riding situation, such as riding on the rear wheel only	<ul style="list-style-type: none"> ▶ Re-start the system. ▶ Take a test ride of at least two minutes. The ABS indicator lamp must go out. ▶ Contact your specialist dealer if the problem persists.
830	Error in the line to the rear wheel speed sensor	<ul style="list-style-type: none"> ▶ Contact your specialist dealer.
831 ... 835	Implausible signals from the rear wheel speed sensor. Sensor disc possibly missing, defective or incorrectly installed; significantly different tyre diameter between the front wheel and rear wheel; extreme riding situation, such as riding on the rear wheel only	<ul style="list-style-type: none"> ▶ Re-start the system. ▶ Take a test ride of at least two minutes. The ABS indicator lamp must go out. ▶ Contact your specialist dealer if the problem persists.
840	Internal ABS error	<ul style="list-style-type: none"> ▶ Contact your specialist dealer.
850	Internal ABS error	<ul style="list-style-type: none"> ▶ Contact your specialist dealer.
860, 861	Error in the power supply	<ul style="list-style-type: none"> ▶ Re-start the system. ▶ Contact your specialist dealer if the problem persists.

Table 51: List of error messages





Code	Description	Method of resolution
870, 871, 880 883 ... 885	Communication error	▶ Re-start the system. ▶ Contact your specialist dealer if the problem persists.
889	Internal ABS error	▶ Contact your specialist dealer.
890	ABS indicator lamp is defective or missing; ABS possibly not functioning	▶ Contact your specialist dealer.
No screen display	Internal display error	▶ Re-start your drive system by switching it on and off.

Table 51: List of error messages

6.2.2 Battery error message

The battery is protected against deep discharge, overcharging, overheating and short circuits by Electronic Cell Protection (ECP). In the event of a hazard, a protective circuit switches the battery off automatically.

If a battery error is detected, two LEDs flash on the battery level indicator. Contact an authorised specialist dealer if this happens.

Code	Description	Method of resolution
	If the battery is outside its charging temperature range, three LEDs will flash on the battery level indicator	▶ Disconnect the battery from its charger until it comes within the charging temperature range. Do not connect the rechargeable battery to the charger again until the permitted charging temperature has been reached.
	If a fault is detected in the battery, two LEDs flash on the battery level indicator	▶ Contact your specialist dealer.
	No LEDs will flash if the charger is defective. One or more LEDs will light up permanently depending on the battery level	▶ Contact your specialist dealer.
	No LEDs will light up if there is no power	▶ Check all plug connections. ▶ Check the contacts on the battery for dirt. Clean the contacts carefully if they need cleaning. ▶ Contact your specialist dealer if the problem persists.

6.3 Before the first ride

Crash caused by incorrectly adjusted torques

If a screw is fastened too tightly, it may break. If a screw is not fastened enough, it may loosen. This will cause a crash with injuries.

- ▶ Always observe the indicated torques on the screw or in the *operating instructions*.

Only a correctly adjusted pedelec will guarantee you the desired ride comfort and health-promoting activity. Therefore adjust the *saddle*, the *handlebars* and the *suspension* to your body and your preferred riding style before the first ride.

6.3.1 Adjusting the saddle

6.3.1.1 Adjusting the saddle tilt

The saddle tilt must be adjusted to the seat height, the saddle and handlebar position, and the saddle shape to ensure an optimum fit. The seating position can be optimised in this way if needed. First, readjust the saddle after finding the handlebar position you prefer.

- ⇒ Place the saddle tilt in the horizontal position to adjust the pedelec to your needs for initial use.

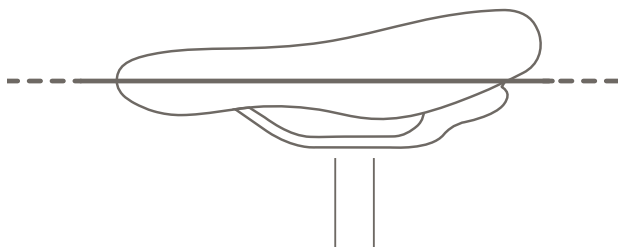

Figure 45: Horizontal saddle tilt

6.3.2 Determining the seat height

- ✓ To determine the seat height safely, either push the pedelec near to a wall, so that you can lean on the wall to support yourself or ask another person to hold the pedelec for you.
- ▶ Climb onto the bicycle.
- ▶ Place your heel on the pedal and extend your leg, so that the pedal is at the lowest crank rotation point.
- ⇒ The rider sits straight on the saddle if the seat is at an optimum height. If this is not the case, you can adjust the length of the seat post to your needs.

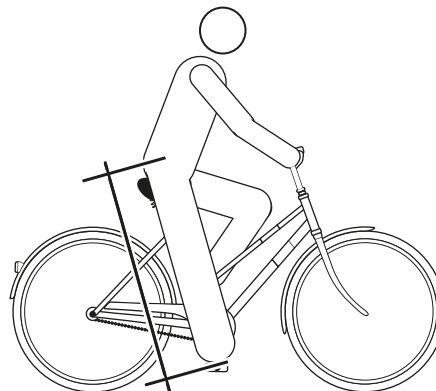

Figure 46: Optimal saddle height

6.3.2.1 Adjusting the seat height with quick release

- ▶ Open the quick release on the seat post to change the seat height. To do so, push the clamping lever away from the seat post.

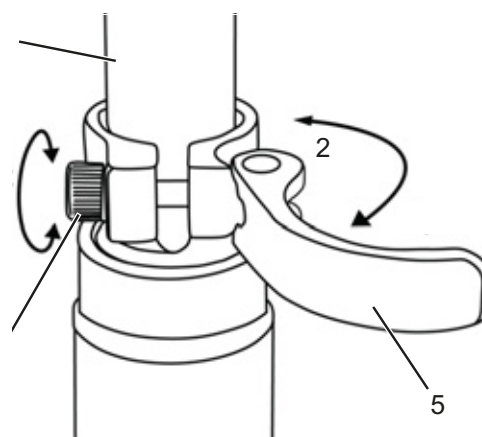

Figure 47: Seat post quick release (3)

The seat post quick release with clamping lever (5) and setting bolt (4) in the open position (1) and in the direction of the closed position (2)

- ▶ Set the seat post at the required height.



Crash caused by an excessively high seat post setting

A *seat post* with is set too high will cause the *seat post* or the *frame* to break. This will cause a crash with injuries.

- ▶ Do not pull the seat post out of the frame beyond the minimum insertion depth marking.

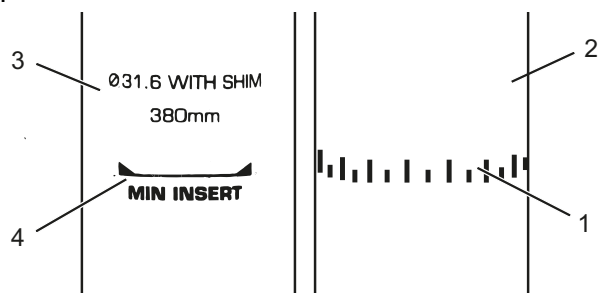

Figure 48: Detailed view of the seat post – examples of the minimum insertion depth marking

- ▶ To close it, push the *seat post clamping lever* as far as it will go into the *seat post*.
- ▶ Check the *clamping force of quick releases*.

6.3.2.2 Height-adjustable seat post

Only applies to pedelecs with this equipment

- ✓ When using your seat post for the first time, you must give it a firm push downwards to set it in motion. This is due to the natural tendency of the seal to repel oil from the seal surface. You only need to do this before the first use or after a longer period of non-use. Once you have displaced the post through its deflection, the oil spreads on the seal and the post begins to function normally.

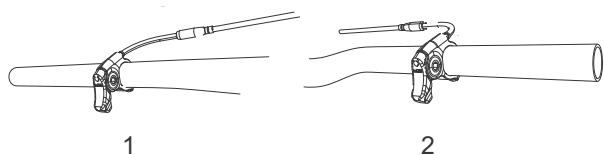

Figure 49: The seat post activation lever can be installed either on the left (1) or the right (2) side of the handlebars

Lowering the saddle

- ✓ To lower the saddle, press your hand down on the saddle or sit on the saddle. Press the seat post activation lever and hold it down.
- ▶ Release the lever once you have reached the required height.

Raising the saddle

- ▶ Pull the seat post activation level.
- ▶ Remove any pressure on the saddle and release the lever once you have reached the required height.

6.3.2.3 Adjusting the seat position

The saddle can be shifted on the saddle frame. The right horizontal position ensures an optimal leverage position for legs. This prevents knee pain and painful incorrect pelvis positions. If you have displaced the saddle more than 10 mm, you then need to adjust the saddle height again since both settings affect one another.

- ✓ To adjust the seat position safely, either push the *pedelec* near to a wall, so that you can lean on the wall to support yourself or ask another person to hold the *pedelec* for you.
- ▶ Climb onto the bicycle.
- ▶ Place the pedals into the vertical position (3 o'clock position) with your feet.
- ⇒ The rider is sitting in the optimal sitting position if the knee cap perpendicular line runs through the pedal axle. If the perpendicular line crosses behind the pedal, bring the saddle forward. If the perpendicular line crosses in front of the pedal, bring the saddle back. Move the saddle within its permitted displacement range only (marked on the saddle stay).

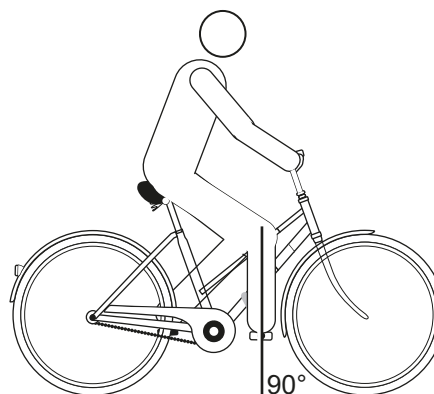

Figure 50: Knee cap perpendicular line



- ✓ The handlebar settings must only be adjusted while the pedelec is stationary.
- ▶ Unfasten and adjust the designated screw connections, and clamp them with the maximum tightening torque for the clamping screws of the handlebars.

6.3.3 Adjusting the handlebars

6.3.3.1 Adjusting the stem



Crash caused by loose stem

Incorrectly fastened screws may come loose due to impact. The stem may no longer be firmly fixed in its position as a result. This will cause a crash with injuries.

- ▶ Check the handlebars and the quick release system are firmly in position after the first two hours of riding.

6.3.3.2 Adjusting the height of the handlebars



Crash caused by incorrectly set clamping force

Excessively high clamping force will damage the quick release and cause it to lose its function. Insufficient clamping force will cause a detrimental transmission of force. This can cause components to break. This will cause a crash with injuries.

- ▶ Never fasten a quick release using a tool (e.g. hammer or pliers).
 - ▶ Only use the clamping lever with the specified set clamping force.
-
- ▶ Open the clamping lever.
 - ▶ Pull the locking lever on the stem up, and simultaneously pivot the handlebars into the desired position.
- ⇒ You feel the locking lever click into place.
- ▶ Pull out the handlebars to the required height.
 - ▶ Lock the quick release.

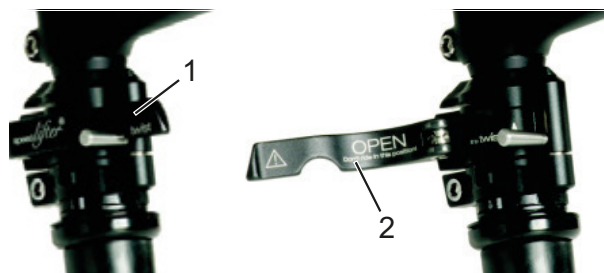

Figure 51: Open (2) and closed (1) clamping lever on the stem; by.schulz speedlifter used as an example

6.3.3.3 Turning the handlebars to the side

Only applies to pedelecs with this equipment



Crash caused by incorrectly set clamping force

Excessively high clamping force will damage the quick release and cause it to lose its function.

Insufficient clamping force will cause a detrimental transmission of force. This will cause a crash with injuries.

- ▶ Never fasten a quick release using a tool (e.g. hammer or pliers).
 - ▶ Only use the clamping lever with the specified set clamping force.
-
- ▶ Open the clamping lever.
 - ▶ Pull the locking lever on the stem up, and simultaneously pivot the handlebars into the desired position.
- ⇒ You feel the locking lever click into place.
- ▶ Pull out the handlebars to the required height.
 - ▶ Lock the quick release.

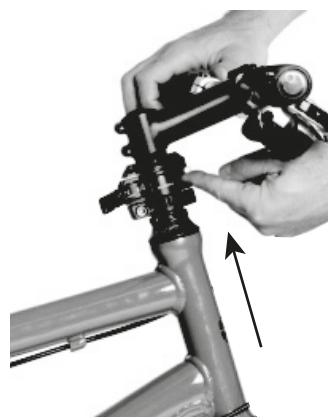

Figure 52: Pushing locking lever upwards – by.schulz speedlifter used as an example

6.3.3.4 Checking the clamping force in quick releases

- ▶ Open and close the quick releases on the stem or the seat post.
- ⇒ The clamping force is sufficient if the clamping lever can be moved easily from the open final position into the middle and has to be pressed with the fingers or base of the thumb from the middle point onwards.

6.3.3.5 Adjusting the quick release clamping force

- ▶ If the *clamping lever on the handlebars* cannot be moved into its final position, screw out the *knurled nut*.
- ▶ Tighten the *knurled nut* on the seat post if the *clamping lever's* clamping force is not sufficient.
- ▶ If you are unable to set the clamping force, the specialist dealer will need to check the quick release.

6.3.4 Adjusting the brake lever

6.3.4.1 Adjusting the pressure point on a Magura brake lever

! WARNING

Brake failure due to incorrect setting

If the pressure point is set with brakes where the brake linings and brake disc have reached their wear limit, the brakes may fail and cause an accident with injury. 

Before you set the pressure point, ensure that the brake linings and brake disc have not reached their wear limit.

The pressure point setting is adjusted using the twist knob.

- ▶ Turn the twist knob towards the plus (+) symbol.
- ⇒ The *brake lever* moves closer to the handlebar grip. Re-adjust the grip distance as necessary.
- ⇒ The lever pressure point activates sooner.

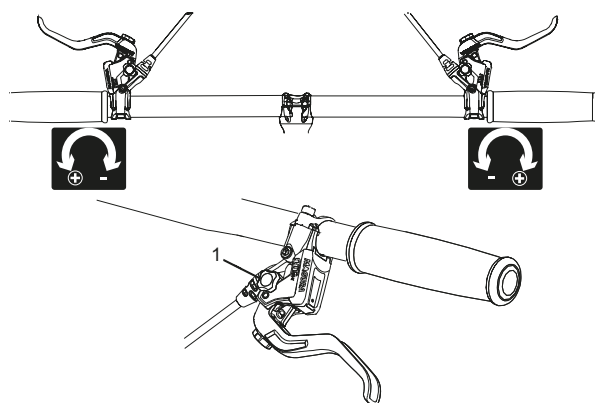

Figure 53: Using the twist knob (1) to adjust the pressure point

6.3.4.2 Adjusting the grip distance

! WARNING

Crash caused by incorrectly set grip distance

If brake cylinders are set incorrectly or installed wrongly, the braking power may be lost at any time. This may cause a crash with injuries.

- ▶ Once the grip distance has been set, check the position of the brake cylinder and adjust it as necessary.

Never correct the brake cylinder position without special tools. Have a specialist dealer correct it.

- ▶ The brake lever grip distance can be adjusted to ensure that it can be reached more easily. Contact your specialist dealer if the brake handle is too far from the handlebars or is hard to use.

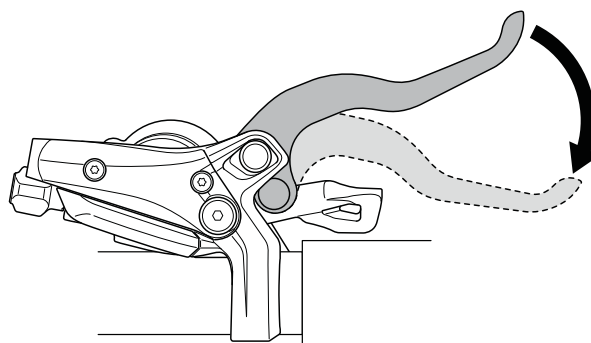

Figure 54: Brake lever grip distance

6.3.4.3 Adjusting the grip distance on a Magura brake lever

Only applies to pedelecs with this equipment

Use a T25 TORX® wrench to turn the setting screw to adjust the grip distance.

- ▶ Turn the setting screw in the minus (-) direction.
 - ⇒ The brake lever moves closer to the handlebar grip.
- ▶ Turn the setting screw in the plus (+) direction.
 - ⇒ The brake lever moves away from the handlebar grip.

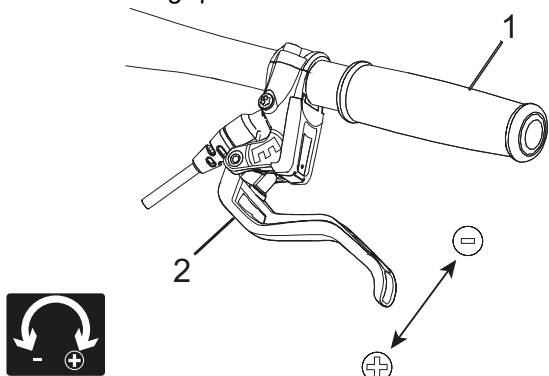

Figure 55: Using the setting screw (2) to adjust the distance from the brake lever to the handlebar grip (1)

6.3.5 Adjusting the suspension of the Suntour fork

Only applies to pedelecs with this equipment

The following Suntour forks can be installed in this series of models:

Aion-35 Boost	Air suspension fork
NCX	Air suspension fork
NEX	Steel suspension fork
XCM-ATB	Steel suspension fork
XCM	Steel suspension fork
XCR32	Air suspension fork
XCR34	Air suspension fork

Figure 56: Overview of Suntour forks

CAUTION

Crash caused by incorrectly set suspension

If the suspension is adjusted incorrectly, the fork may become damaged, so that problems may occur when steering. This will cause a crash with injuries.

- ▶ Never ride the pedelec without air in the air suspension fork.
- ▶ Never use the pedelec without adjusting the suspension fork to the rider's weight.

Notice

Settings on the chassis change riding performance significantly. You need to get used to the pedelec and break it in to prevent accidents.

The adjustment shown here represents a basic setting. The rider should change the basic setting to suit the surface and his/her preferences.

- ▶ It is advisable to make a note of the basic setting. This way, it can be used as the starting point for subsequent, optimised settings and to safeguard against unintentional changes.

6.3.5.1 Adjusting the negative deflection

Negative deflection (sag) is compression of the fork caused by the weight of the rider and their gear (e.g. a backpack), the sitting position and the frame geometry. This sag is not caused by riding.

Each rider has a different weight and sitting position. The sag depends on the rider's position and weight and should be between 15% and 30% of the maximum fork deflection, depending on pedelec usage and preferences.

6.3.5.2 Adjusting the air suspension fork negative deflection

Only applies to pedelecs with this equipment

- ▶ The air valve is located under a cover on the head of the left shock absorber. Screw off the cover.



Figure 57: Screw caps in different designs

- ▶ Screw a high-pressure pump onto the valve.
- ▶ Pump the suspension fork up to the desired pressure. Never exceed the recommended maximum air pressure. Comply with the values of the filling pressure table.
- ▶ Remove the high-pressure pump.

< 55 kg	35 - 50 psi	40 - 55 psi
55 - 65 kg	50 - 60 psi	55 - 65 psi
65 - 75 g	60 - 70 psi	65 - 75 psi
75 - 85 kg	70 - 85 psi	75 - 85 psi
85 - 95 kg	85 - 100 psi	85 - 95 psi
< 100 kg	+ 105 psi	+ 100 psi
Max. pressure	150 psi	180 psi

Table 52: Filling pressure table for Suntour air forks

- ▶ Measure the distance between the crown and the dust wiper of the fork. This distance is the total deflection of the fork.
- ▶ Push a temporarily attached cable tie downward against the dust wiper of the fork.
- ▶ Put on your usual bicycling clothing, including luggage.
- ▶ Sit on the pedelec in your usual riding position and support yourself (e.g. against a wall or tree).

- ▶ Get off the pedelec without allowing it to deflect.
- ▶ Measure the distance between the dust wiper and the cable tie. This dimension is the sag. The sag value should be between 15% (hard) and 30% (soft) of the total fork deflection.
- ▶ Increase or reduce the air pressure until you have reached the desired sag.
- ⇒ Once the sag is correct, re-tighten the blue air cover cap clockwise.
- ⇒ If you cannot achieve the desired sag, you may need to make an internal adjustment. For this purpose, contact your specialist dealer.

6.3.5.3 Adjusting the steel suspension fork negative deflection

Only applies to pedelecs with this equipment

You can adjust the fork by tensioning the spring to the rider's weight and their preferred riding style. It is not the coil spring hardness which is adjusted; it is its pre-tensioning. This reduces the fork's negative deflection when the rider sits on the pedelec.



Figure 58: Negative deflection setting wheel on the suspension fork crown

- ▶ The setting wheel may be located under a plastic cover on the suspension fork crown. Remove the plastic cover by pulling it off upwards.
- ▶ Turn the negative deflection setting wheel in a clockwise direction to increase the spring pre-tensioning. Turn the negative deflection setting wheel in an anti-clockwise direction to reduce it.

⇒ The ideal setting in relation to the weight of the rider has been achieved when the shock absorber deflects 3 mm under the stationary load of the rider. Reattach the cover after the adjustment.

6.3.5.4 Adjusting the rebound

Only applies to pedelecs with this equipment

The rebound defines the speed at which the fork rebounds after being loaded. The rebound setting depends on the air pressure setting. Higher sag settings require lower rebound settings.

- ▶ Turn the rebound adjuster clockwise to the closed position until it stops.

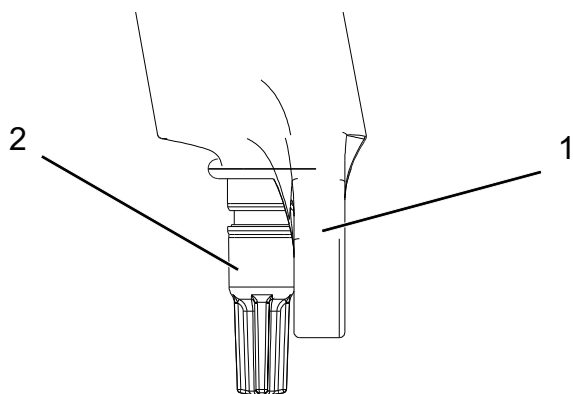

Figure 59: Suntour rebound adjuster (2) on the fork (1)

- ▶ Turn the rebound adjuster anti-clockwise.
- ⇒ Adjust the rebound in such a way that the fork rebounds quickly, but without bottoming out upward during testing. Bottoming out is where the fork rebounds too quickly and stops moving abruptly once it has reached the full rebound distance. You will hear and feel a slight knock when this occurs.

6.3.6 Adjusting the suspension of the FOX fork

Only applies to pedelecs with this equipment



Crash caused by incorrectly set suspension

If the suspension is adjusted incorrectly, the fork may become damaged, so that problems may occur when steering. This will cause a crash with injuries.

- ▶ Never ride the pedelec without air in the air suspension fork.
- ▶ Never use the pedelec without adjusting the suspension fork to the rider's weight.

Notice

Settings on the chassis change riding performance significantly. You need to get used to the pedelec and break it in to prevent accidents.

The adjustment shown here represents a basic setting. The rider should change the basic setting to suit the surface and his/her preferences.

- ▶ It is advisable to make a note of the basic setting. This way, it can be used as the starting point for subsequent, optimised settings and to safeguard against unintentional changes.

6.3.6.1 Adjusting the negative deflection

Negative deflection (sag) is compression of the fork caused by the weight of the rider and their gear (e.g. a backpack), the sitting position and the frame geometry. This sag is not caused by riding. Each rider has a different weight and sitting position. The sag depends on the rider's position and weight and should be between 15% and 20% of the maximum fork deflection, depending on pedelec usage and preferences.

- ✓ When adjusting the sag, ensure that each compression adjuster is in the open position, i.e. turned clockwise until it stops.
- ✓ The pressure is to be measured at an ambient temperature of 21 to 24 °C.
- ▶ The air valve is located under a blue cover on the head of the left shock absorber. Screw off the cover anti-clockwise.
- ▶ Place a high-pressure pump on the valve.

- ▶ Pump the suspension fork up to the desired pressure. Never exceed the recommended maximum air pressure. Comply with the values of the filling pressure table.

- ▶ Remove the high-pressure pump.

Rider weight	Rhythm 34	Rhythm 36
Minimum air pressure	40 psi (2.8 bar)	40 psi (2.8 bar)
54 - 59 kg	58 psi	55 psi
59 - 64 kg	63 psi	59 psi
64 - 68 kg	68 psi	63 psi
68 - 73 kg	72 psi	67 psi
73 - 77 kg	77 psi	72 psi
77 - 82 kg	82 psi	76 psi
82 - 86 kg	86 psi	80 psi
86 - 91 kg	91 psi	85 psi
91 - 95 kg	96 psi	89 psi
95 - 100 kg	100 psi	93 psi
100 - 104 kg	105 psi	97 psi
104 - 109 kg	110 psi	102 psi
109 - 113 kg	114 psi	106 psi
Max. pressure	120 psi (8.3 bar)	120 psi (8.3 bar)

Table 53: Filling pressure table for the FOX air fork

- ▶ Measure the distance between the crown and the dust wiper of the fork. This distance is the "total deflection of the fork."
- ▶ Push the O-ring downward against the dust wiper of the fork. If an O-ring is not available, attach a cable tie to the stanchion temporarily.
- ▶ Put on your usual bicycling clothing, including luggage.
- ▶ Sit on the pedelec in your usual riding position and support yourself (e.g. against a wall or tree).
- ▶ Get off the pedelec without allowing it to deflect.
- ▶ Measure the distance between the dust wiper and the O-ring or cable tie. This dimension is the sag. The recommended sag value is between 15% (hard) and 20% (soft) of the "total fork deflection."

- ▶ Increase or reduce the air pressure until you have reached the desired sag.
- ⇒ Once the sag is correct, re-tighten the blue air cover cap clockwise.

If you cannot achieve the desired sag, you may need to make an internal adjustment. For this purpose, contact your specialist dealer.



6.3.6.2 Adjusting the rebound

The rebound defines the speed at which the fork rebounds after being loaded. The rebound setting depends on the air pressure setting. Higher sag settings require lower rebound settings.

- ▶ Turn the rebound adjuster clockwise to the closed position until it stops.



Figure 60: FOX rebound adjuster (1) on the fork

- ▶ Turn the rebound adjuster anti-clockwise.
- ⇒ Adjust the rebound in such a way that the fork rebounds quickly, but without bottoming out upward during testing. Bottoming out is where the fork rebounds too quickly and stops moving abruptly once it has reached the full rebound distance. You will hear and feel a slight knock when this occurs.

6.3.7 Setting the Suntour rear frame damper

Only applies to pedelecs with this equipment

6.3.7.1 Adjusting the negative deflection

Notice

If the air pressure in the rear frame damper is exceeded or undershot, the damper can be permanently damaged.

Do not exceed the maximum air pressure of 300 psi (20 bar).

Negative deflection (sag) is compression of the rear frame damper caused by the weight of the rider and their gear (e.g. a backpack), the sitting position and the frame geometry. This sag is not caused by riding. Each rider has a different weight and sitting position. The sag depends on the rider's position and weight and should be between 25% and 30% of the maximum Rear frame damper, depending on pedelec usage and preferences.

- ▶ Set the compression adjuster to the OPEN position so that the sag setting is not affected.
- ▶ Remove the cap on the air valve.
- ▶ Attach a high-pressure damper pump to the valve.
- ▶ Adjust the air pressure of the damper so that it corresponds to your weight.
- ▶ Remove the high-pressure pump.
- ▶ Measure the distance between the rubber air chamber seal and the end of the damper. This distance is the "total damper deflection".
- ▶ Put on your usual bicycling clothing, including luggage. Sit on the pedelec in your usual riding position and support yourself against an object such as a wall or tree.
- ▶ Push the O-ring downward against the rubber air chamber seal.
- ▶ Get off the pedelec without allowing it to deflect.
- ▶ Measure the distance between the rubber air chamber seal and the O-ring. This dimension is the sag. The recommended sag value is between 15% (hard) and 25% (soft) of the "total damper deflection."
- ▶ Increase or reduce the air pressure until you have reached the desired sag.

6.3.7.2 Adjusting the rebound

The rebound defines the speed at which the rear frame damper rebounds after being loaded. The rebound setting depends on the air pressure setting. Higher sag settings require lower rebound settings.



Figure 61: Suntour rebound adjuster wheel (1) on the rear frame damper

- ▶ Turn the rebound adjuster wheel in the – direction to increase rebounding.
- ▶ Turn the rebound adjuster wheel in the + direction to reduce compressive deflection movements.

6.3.7.3 Setting the compression

The compression damper setting of the rear frame damper makes it possible to set the damper according to the conditions of the ground. The compression damper setting specifies the speed at which the rear frame damper deflects after being loaded.

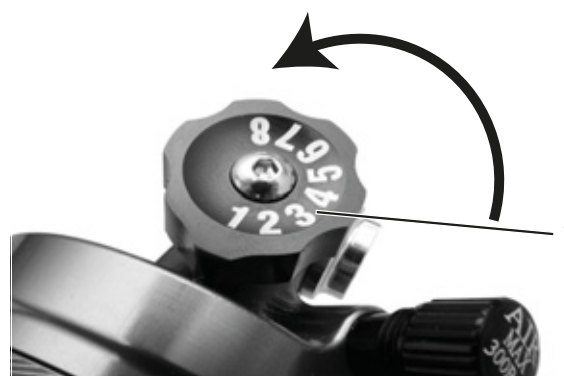

Figure 62: Suntour compression adjuster on the rear frame damper

- ▶ Turn the compression adjuster towards the – symbol to increase rebounding.
- ▶ Turn the compression adjuster towards the + symbol to reduce compressive deflection movement.

6.3.8 Setting the FOX rear frame damper

Only applies to pedelecs with this equipment

6.3.8.1 Adjusting the negative deflection

Notice

If the air pressure in the rear frame damper is exceeded or undershot, the damper can be permanently damaged.

Do not exceed the maximum air pressure of 350 psi (24.1 bar). The minimum air suspension pressure of 50 psi (3.4 bar) must be complied with.

Negative deflection (sag) is compression of the rear frame damper caused by the weight of the rider and their gear (e.g. a backpack), the sitting position and the frame geometry. This sag is not caused by riding. Each rider has a different weight and sitting position. The sag depends on the rider's position and weight and should be between 25% and 30% of the maximum Rear frame damper, depending on pedelec usage and preferences.

- ▶ Set the compression adjuster to the OPEN position.
- ▶ Adjust the air pressure of the damper so that it corresponds to your weight.
- ▶ Attach the high-pressure pump to the damper. Slowly compress the damper over 25% of the deflection 10 times until you have reached the desired pressure. This equalises the air pressure between the positive and negative air chambers, and the pressure indication on the pump manometer changes accordingly.

Remove the high-pressure pump.

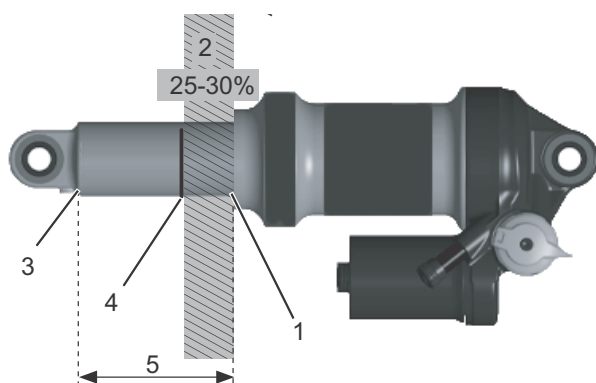

Figure 63: FOX rear frame damper

The negative deflection (2) is the distance between the O-ring (4) and the rubber air chamber seal (1). The total deflection of the rear frame damper (5) is the distance between the end of the rear frame damper (3) and the rubber air chamber seal (1).

- ▶ Measure the distance between the rubber air chamber seal (1) and the end of the damper (3). This distance is the "total damper deflection" (5).
- ▶ Put on your usual bicycling clothing, including luggage. Sit on the pedelec in your usual riding position and support yourself against an object such as a wall or tree.
- ▶ Push the O-ring (4) downward against the rubber air chamber seal (1).
- ▶ Get off the pedelec without allowing it to deflect.
- ▶ Measure the distance between the rubber air chamber seal and the O-ring. This dimension is the sag. The recommended sag value is between 25% (hard) and 30% (soft) of the "total damper deflection" (5).
- ▶ Increase or reduce the air pressure until you have reached the desired sag.

6.3.8.2 Adjusting the rebound

The rebound defines the speed at which the rear frame damper rebounds after being loaded. The rebound setting depends on the air pressure setting. Higher sag settings require lower rebound settings.

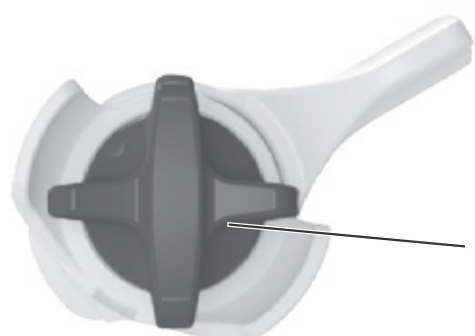

Figure 64: FOX rebound adjuster wheel (1) on the rear frame damper

- ▶ Turn the rebound adjuster clockwise to the closed position until it stops.

- ▶ Determine your rebound setting based on the air pressure. Turn the rebound adjuster back anti-clockwise by the number of clicks specified in the table below:

Air pressure (psi)	Recommended rebound setting
< 100	Open (anti-clockwise)
100 - 120	11
120 - 140	10
140 - 160	9
160 - 180	8
180 - 200	7
200 - 220	6
220 - 240	5
240 - 260	4
260 - 280	3
280 - 300	2

Table 54: Filling pressure table for the FOX air fork

6.3.9 Retracting the brake linings

Disc brakes require wearing-in time. The braking force increases over time. You therefore need to be aware that the braking force may increase during the wearing-in period. The same happens after brake pads or discs are replaced.

- ▶ Accelerate pedelec to about 25 km/h.
- ▶ Brake pedelec until it comes to a halt.
- ▶ Repeat process 30–50 times.
- ▶ The brake linings and brake discs are now retracted and provide optimal braking power.

6.4 Accessories

We recommend a parking stand into which either the front or rear wheel can be inserted securely for pedelecs which do not have a kickstand. The following accessories are recommended:

Description	Article number
Protective cover for electrical components	080-41000 ff
Panniers, system component*	080-40946
Rear wheel basket, system component*	051-20603
Bicycle box, system component*	080-40947
Parking stand universal stand	XX-TWO14B

Table 55: Accessories

*System components are matched to the pannier rack and provide sufficient stability due to special transmission of force.

**System components are matched to the drive system.

6.4.1 Child seat

WARNING

Crash caused by incorrect child seat

Neither the pannier rack nor the pedelec down tube are suitable for child seats and may break. Such an incorrect position may cause a crash with serious injuries for the rider and the child.

Never attach a child seat to the saddle, handlebars or down tube.

CAUTION

Crash caused by improper handling

When using child seats, the pedelec's handling characteristics and stability change considerably. This can cause a loss of control, a crash and injuries.

- ▶ You should practice how to use the child seat safely before using the pedelec in public spaces.

CAUTION

Risk of crushing due to exposed springs

The child may crush his/her fingers on exposed springs or open mechanical parts of the saddle or the seat post.

- ▶ Never install saddles with exposed springs if a child seat is being used.
- ▶ Never install seat posts with suspension with open mechanical parts or exposed springs if a child seat is being used.

Notice

- ▶ Observe the legal regulations on the use of child seats.
- ▶ Observe the operating and safety notes for the child seat system.
- ▶ Never exceed the total weight of the pedelec.

The specialist dealer will advise you on choosing a suitable child seat system for the child and the pedelec.

The specialist dealer must install the child seat the first time to ensure that it is safely fitted.

When installing a child seat, the specialist dealer makes sure that the seat and the fastening mechanism for the seat are suitable for the pedelec and that all components are installed and firmly fastened. They will also ensure that shift cables, brake cables, hydraulic and electrical cables are adjusted as necessary, the rider's freedom of movement is not restricted and the pedelec's permitted total weight is not exceeded.

The specialist dealer will provide instruction on how to handle the pedelec and the child seat.

The specialist dealer will advise you on choosing a suitable child seat system for the child and the pedelec.

The specialist dealer must install the child seat the first time to ensure that it is safely fitted.

When installing a child seat, the specialist dealer makes sure that the seat and the fastening mechanism for the seat are suitable for the pedelec and that all components are installed and firmly fastened. They will also ensure that shift

cables, brake cables, hydraulic and electrical cables are adjusted as necessary, the rider's freedom of movement is not restricted and the pedelec's permitted total weight is not exceeded.

The specialist dealer will provide instruction on how to handle the pedelec and the child seat.

6.4.2 Bicycle trailers

CAUTION

Crash caused by brake failure

The brake may not work sufficiently if there is an excessive trailer load. The long braking distance can cause a crash or an accident and injuries.

- ▶ Never exceed the specified trailer load.

Notice

- ▶ The operating and safety notes for the trailer system must be observed.
- ▶ The statutory regulations on the use of bicycle trailers must be observed.
- ▶ Only use type-approved coupling systems.

A pedelec which is approved for towing a trailer will bear an appropriate adhesive label. Only bicycle trailers with a support load and total mass which do not exceed the permitted values may be used.

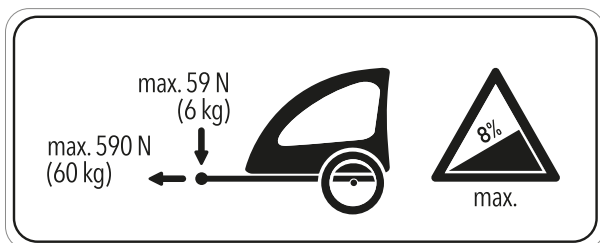

Figure 65: Trailer sign

The specialist dealer will advise on choosing a suitable trailer system for the pedelec. The specialist dealer must install the trailer the first time to ensure that it is safely fitted.

6.4.3 Pannier rack

The specialist dealer will advise on choosing a suitable pannier rack.

The specialist dealer must install the pannier rack the first time to ensure that it is safely fitted.

When installing a pannier rack, the specialist dealer will make sure that the fastening mechanism for the rack is suitable for the pedelec and that all components are installed and firmly fastened. They will also ensure that shift cables, brake cables and hydraulic and electrical lines are adjusted as necessary, the rider's freedom of movement is not restricted and the permitted total weight of the pedelec is not exceeded.

The specialist dealer will provide instruction on how to handle the pedelec and the pannier rack.

6.5 Before each ride



Crash caused by difficult-to-spot damage

If the pedelec topples over or you have a fall or an accident, there may be difficult-to-spot damage to components such as the brake system, quick releases or *frame*. This may cause a crash with injuries.

- ▶ Take the pedelec out of service and have a specialist dealer carry out an inspection.

Crash caused by material fatigue

Intensive use can cause material fatigue. A component may suddenly fail in case of material fatigue. This may cause a crash with injuries.

- ▶ Remove the pedelec from service immediately if there are any signs of material fatigue. Have the specialist dealer check the state.
- ▶ Have the specialist dealer carry out a basic inspection regularly. During the inspection, the specialist dealer will inspect the pedelec for any signs of material fatigue on the frame, fork, suspension element mountings (if there are any) and components made of composite materials.

Carbon becomes brittle when exposed to heat radiation such as heating. This can cause the carbon part to break and result in a crash with injuries.

- ▶ Never expose carbon parts on the pedelec to strong sources of heat.

6.6 Check list before each ride

- ▶ Check the pedelec before each ride.

⇒ Do not use the pedelec if there is evidently something wrong with it.

<input type="checkbox"/>	Check that the pedelec is complete.
<input type="checkbox"/>	Check the battery is firmly in place.
<input type="checkbox"/>	Check that the lighting, reflector and brake, for instance, are sufficiently clean.
<input type="checkbox"/>	You must check that the mudguards, the pannier rack and the chain guard are securely installed.
<input type="checkbox"/>	Check that the front and rear wheels run true. This is particularly important if the pedelec been transported or secured with a lock.
<input type="checkbox"/>	Check the valves and the tyre pressure. Adjust as necessary before each ride.
<input type="checkbox"/>	If the pedelec has a hydraulic rim brake, check whether the locking levers are fully closed in their final positions.
<input type="checkbox"/>	Check the front and rear wheel brakes to make sure that they are working properly. To do so, push the brake levers while stationary to check whether resistance is generated in the usual brake lever position. The brake must not lose any brake fluid.
<input type="checkbox"/>	Check that the riding light is working.
<input type="checkbox"/>	Check for unusual noises, vibrations, smells, staining, deformation, cracks, scores, abrasion and wear. This indicates material fatigue.
<input type="checkbox"/>	Inspect suspension system for cracks, dents, bumps, parts or leaking oil. Look at concealed sections on the pedelec's lower surface.
<input type="checkbox"/>	Use body weight to compress suspension system. Adjust to the optimum sag value if suspension is too soft.
<input type="checkbox"/>	If quick releases are used check them to make sure that they are fully closed in their end position. If quick release axle systems are used, make sure that all attachment screws are tightened to the correct torque.
<input type="checkbox"/>	Be alert to any unusual operating sensations when braking, pedalling or steering.
<input type="checkbox"/>	Check that the ABS indicator lamp lights up correctly on pedelecs with an ABS system.

6.7 Using the kickstand



CAUTION

Crash caused by a lowered kickstand

The kickstand does not fold up automatically. There is a risk of crashing if riding with the kickstand lowered.

- ▶ Raise the kickstand completely before setting off.

Notice

The pedelec's force of weight may cause the kickstand to sink into soft ground and the pedelec may topple over.

- ▶ The pedelec must be parked on firm, level ground only.
- ▶ It is particularly important to check that the pedelec is stable if it is equipped with accessories or loaded with baggage.

6.7.1 Raising the kickstand

- ▶ Before the ride, raise the kickstand completely with your foot.

6.7.1.1 Parking the pedelec

- ▶ Use your foot to lower the kickstand completely before parking.
- ▶ Park the pedelec carefully and check that it is stable.

6.8 Using the pannier rack



CAUTION

Crash caused by loaded pannier rack

The pedelec is handled differently with a loaded *pannier rack*, in particular when the rider needs to steer and brake. This can lead to a loss of control. This may cause a crash with injuries.

- ▶ You should practice how to use a loaded *pannier rack* safely before using the pedelec in public spaces.



CAUTION

Crash caused by unsecured baggage

Loose or unsecured objects on the *pannier rack*, e.g. belts, may become caught in the rear wheel. This may cause a crash with injuries.

Objects which are fastened to the *pannier rack* may cover the pedelec's *reflectors* and the *riding light*. Other users may not see the pedelec on public roads as a result. This may cause a crash with injuries.

- ▶ Secure any objects which are attached to the *pannier rack* sufficiently.
- ▶ Objects fastened to the *pannier rack* must never cover the *reflectors*, the *headlight* or the *rear light*.

Crushing the fingers in the spring flap

The spring flap on the *pannier rack* operates with a high clamping force. There is a risk of crushing the fingers.

- ▶ Never allow the spring flap to snap shut in an uncontrolled manner.
- ▶ Be careful where you position your fingers when closing the spring flap.

Notice

The maximum load bearing capacity is indicated on the *pannier rack*.

- ▶ Never exceed the permitted *total weight* when loading the pedelec.
- ▶ Never exceed the maximum load bearing capacity of the *pannier rack*.
- ▶ Never modify the *pannier rack*.
- ▶ Distribute the baggage as evenly as possible on the left- and right-hand side of the pedelec.
- ▶ We recommend the use of panniers and baggage baskets.

6.9 Rechargeable battery

WARNING

Risk of fire and explosion due to faulty battery

The safety electronics on a damaged or faulty battery may fail. The residual voltage can cause a short circuit. The battery may self-ignite and explode.

- ▶ Remove batteries with external damage from service immediately and never charge them.
- ▶ Only operate the battery and accessories if they are in perfect condition.
- ▶ Only use batteries which are approved for use on your pedelec.
- ▶ Do not use the battery with defective connecting cables or defective contacts.
- ▶ Use the battery with BOSCH Systems pedelecs only. This is the only way that the battery will be protected from dangerous overloading.
- ▶ If the battery becomes deformed or begins to smoke, keep at a safe distance, disconnect the power supply at the socket, and notify the fire service immediately.
- ▶ Never extinguish a damaged battery with water or allow it to come into contact with water.
- ▶ If a battery is dropped or struck but shows no signs of external damage, remove it from service and observe it for at least 24 hours.
- ▶ Faulty batteries are hazardous goods. Dispose of faulty batteries properly and as quickly as possible.
- ▶ Store in a dry place until disposal. Never store in the vicinity of flammable substances.
- ▶ Never open or repair the battery.
- ▶ Charge the battery before use. Only use the charger included in the scope of delivery.
- ▶ Avoid wide temperature fluctuations.

CAUTION

Chemical burns to the skin and eyes caused by faulty battery

Liquids and vapours may leak from a damaged or faulty battery. Excessive temperatures can also cause liquid to leak from the battery and the battery will become damaged. Such liquids can irritate the airways and cause burns.

- ▶ Avoid any contact with leaked liquids:
 - Immediately consult a doctor if liquid comes into contact with eyes or causes any discomfort.
 - If liquid comes into contact with the skin, rinse off immediately with water.
 - Ventilate the room well.
- ▶ Protect the battery against heat over 60 °C, e.g. against permanent direct sunlight.

Risk of fire and explosion due to short circuit

Small metal objects may jumper the electrical connections of the battery. The battery may self-ignite and explode.

- ▶ Keep paper clips, screws, coins, keys and other small parts away and do not insert them into the battery.

Risk of fire and explosion due to penetration by water

The battery is only protected from simple spray water. Penetration by water can cause a short circuit. The battery may self-ignite and explode.

- ▶ Never immerse the battery in water.
- ▶ Never clean the battery with pressure washer
- ▶ If there is reason to believe that water may have entered into the battery, the battery must be removed from service.

Notice

If you leave a key inserted when riding or transporting the pedelec, it may break off or the locking system may open accidentally.

- ▶ Remove the key from the battery lock immediately after use.
- ▶ We recommend that you attach the key to a key ring.

- ✓ Switch off the battery and the drive system before removing or inserting the battery.

6.9.1 Frame battery

Only applies to pedelecs with this equipment

6.9.1.1 Removing the frame battery

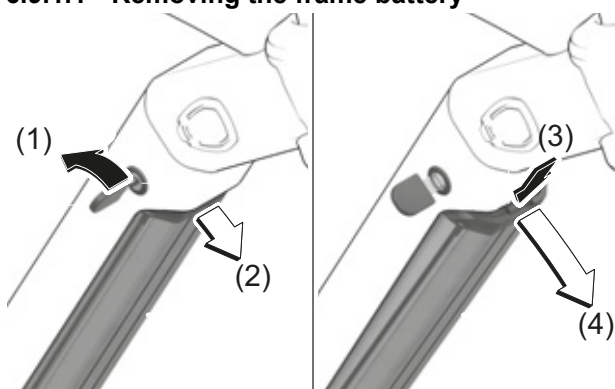

Figure 66: Removing and inserting the frame battery

- ▶ (1) Open the lock with the key.
- ▶ Tip the battery out of the top mount.
- ▶ (2) Pull the battery out of the mount.

6.9.1.2 Inserting the frame battery

- ▶ (3) Place the battery on the contacts in its lower mount.
- ▶ (4) Remove the key from the lock.
- ▶ Tip the battery into the top mount as far as it will go.
- ⇒ There is an audible clicking noise.
- ▶ Check the battery to make sure it is firmly in place.

6.9.2 Pannier rack battery

Only applies to pedelecs with this equipment

6.9.2.1 Removing the pannier rack battery

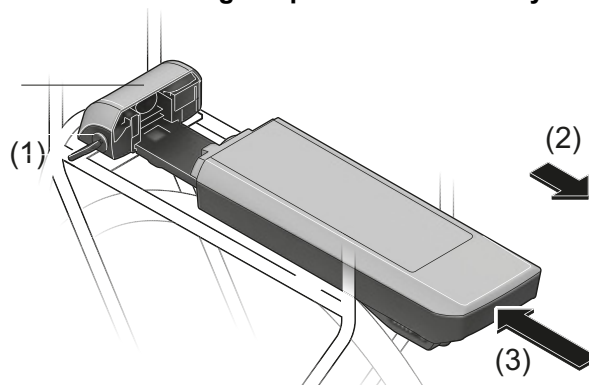

Figure 67: Removing (2) and inserting (3) the pannier rack battery

- ▶ (1) Open the battery lock with the key.
- ▶ (2) Pull the pannier rack battery backwards and out of its *mount*.
- ▶ Remove the key from the lock.

6.9.2.2 Inserting the pannier rack battery

- ▶ (3) Insert the pannier rack battery into its *mount* with the contacts facing the front until it clicks into place.
- ▶ Check battery to make sure it is firmly in place.

6.9.3 Integrated battery

Only applies to pedelecs with this equipment

6.9.3.1 Removing the integrated battery

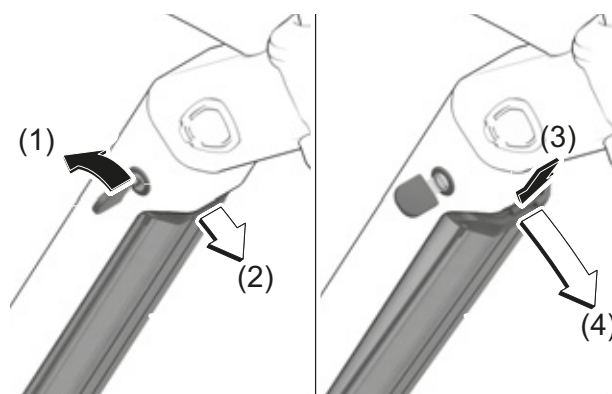

Figure 68: Removing the integrated battery

- ▶ (1) Open the battery lock with the key.
- ⇒ (2) The battery is released and falls into the retainer guard.
- ▶ (3) Hold the battery in your hand from beneath. Use the other hand to push on the retainer guard from above.
- ⇒ (4) The battery is released and falls into the hand.
- ▶ Remove the battery from the frame.
- ▶ Remove the key from the lock.

6.9.3.2 Inserting the integrated battery

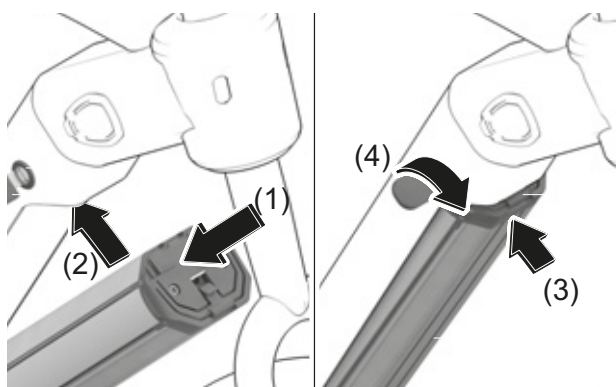

Figure 69: Inserting the integrated battery

- ▶ (1) Place the battery into the lower mount with the contacts facing the front.
- ▶ (2) Flip the battery upwards, so that it is held by the retainer guard.
- ▶ (3) Push the battery upwards, so that it audibly clicks into place.
- ▶ Check battery to ensure it is firmly in place.
- ▶ (4) Lock the battery with the key; otherwise, the battery may fall out of the mount when you open the lock.
- ▶ Remove the key from the lock.
- ▶ Check the battery to ensure it is firmly in place.

6.9.4 Charging the battery

! WARNING

Risk of fire and explosion due to faulty battery

The safety electronics on damaged or faulty batteries may fail. The residual voltage can cause a short circuit. Batteries may self-ignite and explode.

- ▶ Never charge a faulty battery

! CAUTION

Fire caused by overheated charger

The charger heats up when charging the battery. In case of insufficient cooling, this can result in fire or burns to the hands.

- ▶ Never use the charger on a highly flammable surface (e.g. paper, carpet etc.).
- ▶ Never cover the charger during the charging process.
- ▶ Never leave battery unattended during charging.

Electric shock caused by penetration by water

If water penetrates into the charger, there is a risk of electric shock.

- ▶ Never charge the battery outdoors.

Electric shock in case of damage

Damaged chargers, cables and plug connectors increase the risk of electric shock.

- ▶ Check the charger, cable and plug connector before each use. Never use a damaged charger.

Notice

- ▶ If an error occurs during the charging process, a system message is displayed. Remove the charger and battery from operation immediately and follow the instructions.

- ✓ The ambient temperature during the charging process must be within the range from 0 °C to 40 °C.
- ✓ The battery can remain on the pedelec or can be removed for charging.
- ✓ Interrupting the charging process does not damage the battery.
- ✓ If pedelec features two batteries, charging for both batteries is started via pannier rack battery.
 - ▶ Remove the rubber cover from the battery.
 - ▶ Connect the mains plug of the charger to a normal domestic, grounded socket.

Connection data	230 V, 50 Hz
-----------------	--------------

Notice

- ▶ Check that mains voltage is correct. The power source voltage must match the voltage indicated on the charger nameplate. Chargers labelled 230 V may also be operated at 220 V.

- ▶ Connect the charging cable to the battery's charging port.
- ✓ The charging process starts automatically.
- ⇒ The battery level indicator shows the charge level during charging. When the drive system is switched on, the *display screen* shows the charging process.



- ⇒ If the battery is outside its charging temperature range, three LEDs will flash on the battery level indicator

- ✓ Disconnect the battery from the charger and allow it to cool down. Do not connect the rechargeable battery to the charger again until the permitted charging temperature has been reached.
- ⇒ The charging process is complete when the LEDs on the operating status and battery level indicator go out.
- ▶ Once charging is complete, disconnect the battery from the charger and the charger from the mains.

6.9.5 Charging the dual battery

Only applies to pedelecs with this equipment

One of the charging sockets is not accessible or is closed with an end cap on Pedelecs with two batteries.

Notice

- ▶ Charge the battery via the accessible charging socket only.
- ▶ Never open a closed charging socket. Charging via a pre-closed charging socket can cause irreparable damage

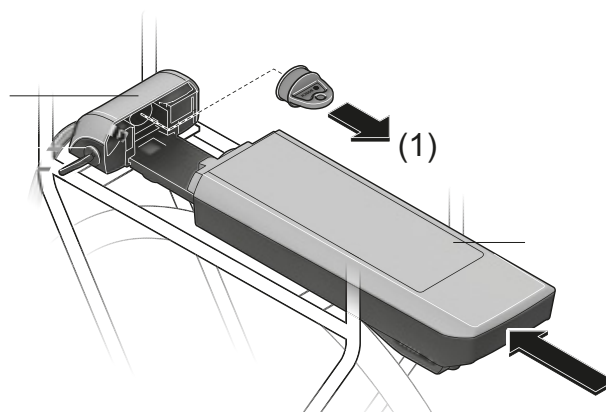

Figure 70: Covering open contacts with cover cap – example: pannier rack battery

- ▶ (1) If you wish to battery use just one battery on a pedelec which is designed for two batteries, cover the contacts on the free slot with the supplied cover cap; otherwise, there is a risk of a short circuit caused by the open contacts.

6.9.5.1 Charging process when two batteries are used

- ▶ If two batteries are attached to a pedelec, charge the two batteries via the non-closed socket.
- ⇒ The two batteries are charged alternately during the charging process. Charging switches automatically between the two batteries several times. The charging time is twice as long.

The two batteries are discharged alternately during use.

6.9.5.2 Charging process when one battery is used

You can charge each battery individually if you remove them from their mounts.

If only one battery is used, you will only be able to charge the battery on the pedelec which has an accessible charging socket. You can only charge battery with the closed charging socket if you remove it from its mount.

6.9.6 Waking the battery

- ✓ The battery switches to sleep mode to protect itself when not used for a longer period. The LEDs on the operating status and battery level indicator do not light up.
- ▶ Press the *On-Off button (battery)*.
- ⇒ The battery's operating status and battery level indicator shows the battery level.

6.10 Electric drive system

6.10.1 Switching on the electric drive system



Crash caused by lack of readiness for braking

When it is switched on, the drive system can be activated by the application of force on the pedals. There is a risk of a crash if the drive is activated unintentionally, and the brake is not reached.

- ▶ Never start the electric drive system, or switch it off immediately, if the brake cannot be reached safely and reliably.

- ✓ A sufficiently charged battery has been inserted into the pedelec.
- ✓ The battery is firmly positioned. The key has been removed.

There are three options for switching on the drive system.

1 On-Off button

- ▶ Press the **On-Off button (battery)** briefly.

2 Display On-Off button

- ▶ Press the **On-Off button (display)** once.

3 Switched-on display

- ▶ If the display is already switched on when it is inserted into its mount, the electric drive system is switched on automatically.
- ⇒ After switching on, a speed of 0 KM/H is displayed on the *display*. If this is not the case, you must check whether the *display* has been engaged properly in place.
- ⇒ If the drive system is switched on, the drive is activated as soon as the pedals are moved with sufficient force (except if in push assist mode or the level of assistance is "OFF").
- ⇒ The motor power is determined by the level of assistance set on the display.
- ⇒ As soon as the system has been activated, ACTIVE LINE/PERFORMANCE LINE appears briefly on the *display*.

6.10.2 Switching off the drive system

As soon as you stop pushing the pedals in normal mode or reach a speed of 25 km/h, the drive system switches off the assistance system. The assistance system starts up again if you push the pedals and your speed is less than 25 km/h.

The system switches off automatically ten minutes after the last command. There are three options for switching off the drive system manually.

1 Display On-Off key

- ▶ Press the **On-Off button (display)** once.

2 On-off button

- ▶ Press the **On-Off button (battery)**.

3 Removing the display

- ▶ Remove the *display* from the mount.

⇒ The LEDs on the operating status and battery level indicator go out.

6.11 Control panel with display



Crash caused by distraction

A lack of concentration while riding increases the risk of an accident. This may cause a crash with serious injuries.

- ▶ Never allow yourself to be distracted by the display.
- ▶ Stop pedelec if you want to make inputs on the display other than a change in level of assistance. Only enter data when the bicycle is stationary.

Notice

- ▶ Do not use the display as a handle. You may irreparably damage the display if you use it to lift the pedelec.
- ▶ If you do not use your pedelec for several weeks, remove the display from its mount. Store the display safely at room temperature in a dry environment.

The internal display battery discharges when it is not in use. This can cause damage to the internal display battery.

- ▶ Charge the internal display battery every 3 months for at least 1 hour.

The system is switched off by removing the display.

6.11.1 Using the USB port

Notice

The USB port is reserved to connect diagnostics systems. The USB port must be kept completely closed with the protective cap at all times.

Any moisture which enters through the USB port may trigger a short circuit in the display.

- ▶ Regularly check the position of the rubber cover on the USB port and adjust it as necessary.

6.11.2 Replacing the battery

- ✓ When the on-board computer indicates LOW BAT on the screen, the battery is flat and must be replaced.

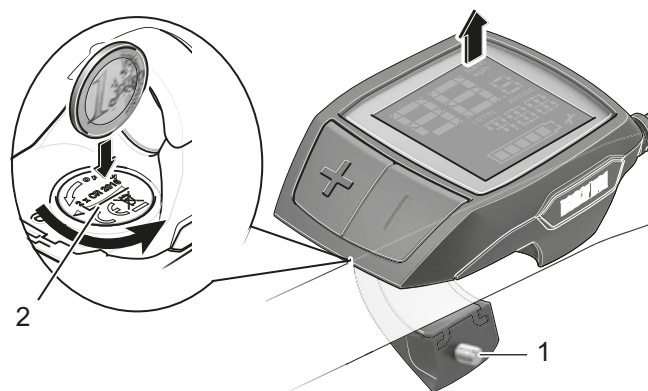

Figure 71: Display with attachment screw (1) and battery compartment cover (2)

- ▶ Remove the display from the handlebars by unfastening the display attachment screw (1).
- ▶ Use a suitable coin to open the battery compartment cover (2).
- ▶ Remove the used batteries.
- ▶ Insert new CR 2016 display batteries. You can obtain the batteries recommended by Bosch from your specialist dealer. Ensure correct polarity when inserting the display batteries.
- ▶ Close the battery compartment again and fasten the on-board computer to your pedelec's handlebars with the attachment screw (1).

6.11.3 Overview of actions





Action	Button	Duration
Switching on the display		Any
Switching off the display		Any
Activate push assist Use push assist	WALK +	1. < 1 second 2. Any
Switch on bicycle lighting	+	1–2.5 seconds
Switch off bicycle lighting	+	> 2.5 seconds
Increase assistance	+	< 1 second
Reduce assistance	–	< 1 second
TRIP/TOTAL/RANGE screen, assistance modes	–	1–2.5 seconds
Reset journey distance	– +	> 2.5 seconds
Switch from kilometres to miles		– 1. Hold 2. < 1 second
Get versions		+ 1. Hold 2. < 1 second
Set display brightness		+ 1. Hold 2. < 1 second

Table 56: Overview of actions

6.11.4 Switching on the display

- ▶ Press the *On-Off button (display)* once.
- ⇒ The electric drive system is switched on.

6.11.5 Switching off the display

If the display is not inserted into the mount, it will switch off automatically after one minute to save energy if no button is pressed.

- ▶ Press the *On-Off button (display)* once.
- ⇒ The electric drive system is switched off.

6.12 Using the push assist system



Injury from pedals or wheels

The pedals and the drive wheel turn when the push assist system is used. There is a risk of injury if the pedelec wheels are not in contact with the ground when the push assist system is used (e.g. when carrying the pedelec up stairs or when placing it on a bicycle rack).

- ▶ Only use the push assist mode when pushing the pedelec.
- ▶ You must steer the pedelec securely with both hands when using push assist.
- ▶ Allow for enough freedom of movement for the pedals.

Notice

The push assist cannot be activated at the OFF assistance level.

The push assist helps the rider to push the pedelec. The speed can be a maximum of 6 km/h in this case.

- ✓ The tractive power of the push assist and its speed can be influenced by the selection of gear. To spare the drive, first gear is recommended for travelling uphill.
- ✓ The level of assistance OFF must not be selected.
- ▶ Press the *push assist button* to activate the push assist.
- ▶ Press and hold the *plus button* within 3 seconds to switch on the push assist.
- ▶ Release the *plus button* to shut off the push assist. The push assist system switches off automatically as soon as the pedelec wheels are blocked or the speed exceeds 6 km.

6.12.1 Using the riding light

- ✓ The drive system needs to be already switched on to turn on the *riding light*.
- ▶ Push the *plus button* for 1 to 2.5 seconds.
- ⇒ The *riding light* is switched on (*riding light symbol* is displayed).
- ▶ Push the *plus button* for longer than 2.5 seconds.
- ⇒ The riding light is switched off (*riding light symbol* is not displayed).

6.12.2 Selecting the level of assistance

- ▶ Press the *plus button* for less than one second to increase the level of assistance.
- ▶ Press the *minus button* for less than one second to decrease the level of assistance.

6.12.3 Journey information

The displayed *journey information* can be changed and partially reset.

6.12.3.1 Resetting the trip distance

- ▶ Select the TRIP journey distance to reset the TRIP journey distance. Press and hold both the plus and minus buttons at the same time.
- ⇒ RESET will appear on the display.
- ⇒ If you continue pressing both buttons, the TRIP journey distance will be re-set to 0.

6.12.3.2 Resetting the range

- ▶ Select RANGE to reset the RANGE.
- ▶ Press both the plus and minus buttons for a long time at the same time.
- ⇒ RESET will appear on the display.
- ⇒ If you continue to press both buttons, the TRIP journey distance will be set to 0.

6.12.3.3 Changing the tachometer from kilometres to miles

You can change the displayed values from kilometres to miles.

- ▶ Hold the minus button down and press the on/off button briefly.
- ⇒ The value is changed from kilometres to miles.

6.12.3.4 Displaying versions and type numbers

You can retrieve the sub-system versions and their type part numbers for maintenance purposes if the sub-systems provide this type of information (depends on the sub-system).

- ✓ The drive system must be switched off.
- ▶ Press and hold the plus and minus buttons at the same time while the system is off.
- ▶ Then press the on/off button.

6.13 Brake

DANGER

Hydraulic fluid can be fatal if it is swallowed and penetrates into the respiratory system

Hydraulic fluid may leak out after an accident or due to material fatigue. Hydraulic fluid can be fatal if swallowed and inhaled.

First aid treatment

- ▶ Wear gloves and safety goggles as protective equipment. Keep unprotected persons away.
- ▶ Remove those affected from the danger area to fresh air. Never leave those affected unattended.
- ▶ Ensure sufficient ventilation.
- ▶ Immediately remove clothing items contaminated with hydraulic fluid.
- ▶ Serious slip hazard due to hydraulic fluid leakage.
- ▶ Keep away from naked flames, hot surfaces and sources of ignition.
- ▶ Avoid contact with skin and eyes.
- ▶ Do not inhale vapours or aerosols.

After inhalation

- ▶ Take in fresh air; consult doctor if any pain or discomfort.

After skin contact

- ▶ Wash affected skin with soap and water and rinse well. Remove contaminated clothing. Consult doctor if any pain or discomfort.

After contact with eyes

- ▶ Rinse eyes under flowing water for at least ten minutes with the lids open; also rinse under lids. Consult eye doctor if pain or discomfort continues.

DANGER

After swallowing

- ▶ Rinse out mouth with water. Never induce vomiting! Risk of aspiration!
- ▶ Place a person lying on their back who is vomiting in a stable recovery position on their side. Seek medical advice immediately.

Environmental protection measures

- ▶ Never allow hydraulic fluid to flow into the sewage system, surface water or groundwater.
- ▶ Notify the relevant authorities if fluid penetrates the ground or pollutes water bodies or the sewage system.

WARNING

Crash caused by brake failure

Oil or lubricant on the brake disc in a disc brake or on the rim of a rim brake can cause the brake to fail completely. This may cause a crash with serious injuries.

- ▶ Never allow oil or lubricant to come into contact with the brake disc or brake linings or on the rim of a rim brake.
- ▶ If the brake linings have come into contact with oil or lubricant, contact a dealer or a workshop to have the components cleaned or replaced.

If the brakes are applied continuously for a long time (e.g. while riding downhill for a long time), the fluid in the brake system may heat up. This may create a vapour bubble. This will cause air bubbles or any water contained in the brake system to expand. This may suddenly make the lever travel wider. This may cause a crash with serious injuries.

- ▶ Release the brake regularly when riding downhill for a longer period of time.

WARNING

Amputation due to rotating brake disc

The brake disc in disc brakes is so sharp that it can cause serious injuries to fingers if they are inserted into the disc brake openings.

Always keep fingers well away from the rotating brake disc.

CAUTION

Crash caused by wet conditions

The *tyres* may slip on wet roads. In wet conditions you must also expect a longer braking distance. The braking sensation differs from the usual sensation. This can cause loss of control or a crash, which may result in injuries.

- ▶ Ride slowly and brake in good time.

Crash caused by incorrect use

Handling the brake improperly can lead to loss of control or crashes, which may result in injuries.

- ▶ Shift your body weight backwards and down as far as possible.
- ▶ Practice braking and emergency braking before using the pedelec in public spaces.
- ▶ Never use the pedelec if you can feel no resistance when you grip the brake handle. Consult a specialist dealer.

Burns caused by heated brake

The brakes may become very hot during operation. There is a risk of burns or fire in case of contact.

- ▶ Never touch the components of the brake directly after the ride.

CAUTION

Crash after cleaning or storage

The brake system is not designed for use on a pedelec which is placed on its side or turned upside down. The brake may not function correctly as a result. This can cause a crash, which may result in injuries.

- ▶ If the pedelec is placed on its side or turned upside down, apply the brake a couple of times before setting off to ensure that it works as normal.
- ▶ Never use the pedelec if it no longer brakes as normal. Consult a specialist dealer.

The drive force of the motor is shut off during the ride as soon as the rider no longer pedals. The drive system does not switch off when braking.

- ▶ In order to achieve optimum braking results, do not pedal while braking.

6.13.1 Using the brake lever

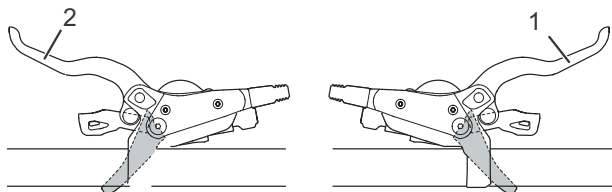

Figure 72: Front (2) and rear (1) brake lever; Shimano brake used as an example

- ▶ Push the *left brake lever for the front wheel brake and the right lever for the rear wheel brake* until the desired speed is reached.

6.13.2 Using the back-pedal brake

Only applies to pedelecs with this equipment

- ✓ The best braking effect is achieved if the pedals are in the 3 o'clock and 9 o'clock position when braking. To bridge the free travel between the riding movement and the braking movement, it is recommendable to pedal a little beyond the 3 o'clock and 9 o'clock position before you pedal in the opposite direction to the *direction of travel* and start braking.
- ▶ Pedal in the opposite direction to the *direction of travel* until the desired speed has been reached.

6.13.3 Using ABS

Only applies to pedelecs with this equipment



Accident due to ABS failure

If the ABS indicator lamp is lit, the ABS function is not active.

- ▶ Adapt riding to the circumstances.

In extreme riding situations, the ABS may not be able to regulate until the pedelec comes to a halt. This may cause a crash with serious injuries.

- ▶ Release the front wheel brake briefly. This allows you to brake with the ABS function again.
- ▶ Adjust your riding to the current ambient conditions and your personal riding skills

An ABS malfunction cannot be displayed if the ABS indicator lamp is faulty.

- ▶ Ensure that the ABS indicator lamp lights up when you start up the electric drive system; if it doesn't, the indicator lamp is faulty.



Accidents on bends and slippery ground

You are at greater risk of falling off if you use ABS braking manoeuvres on bends. It is easier for tyres to skid on slippery ground, meaning there is a greater risk of falling off. This may cause a crash with serious injuries.

- ▶ Adjust your riding to the current ambient conditions and your personal riding skills

Accidents due to extended braking distance

The ABS suppresses blocking on the front wheel. This may cause the braking distance to be longer in some situations. This may cause an accident with serious injuries.

- ▶ Adjust your riding to the current ambient conditions and your personal riding skills
- ▶ Never fool about when riding.

Accidents due to air in the hydraulic system

Air in the brake system can mean less brake pressure builds up, particularly when the ABS has activated causing the brake lever to move closer to the handlebars. This may cause an accident with serious injuries.

- ▶ It's therefore important to pull on the brake before each ride to check whether you can reach a clearly noticeable pressure point and whether the gap between the brake lever and handlebar grip is still sufficient. The pressure point should arise at about third of the brake lever path.
- ▶ If in doubt, place the lever path adjuster in the maximum possible position.
- ▶ If any air has entered the brake system, contact your specialist dealer.
- ▶ Adjust your riding to the current ambient conditions and your personal riding skills

WARNING

Accidents due to manipulation

Modified or manipulated ABS components or use of non-authorized replacement components will have an adverse effect on the ABS function. This may cause a crash with serious injuries.

- ▶ Always carry out maintenance work and repairs correctly.
- ▶ Replace defective components with original parts only.

CAUTION

Damage to components or risk of crushing

There is a gap between the ABS control unit and the frame. Components or body parts can be crushed if the handlebars are turned completely. This can cause injuries or damage to components.

- ▶ Ensure you do not pinch any components such as brake cables, wiring or parts of your body between the frame and the ABS control unit.
- ▶ If you wish to fasten accessories to the handlebars, ensure that handlebars can move freely to each side by at least 60° from their central position. You can prevent fingers becoming trapped with a clearance of 25 mm. Steering limiters should be used if necessary.

6.13.3.1 While riding

The anti-blocking system indicator lamp must light up after the system has started up and must go out once speed has reached about 5 km/h. If the ABS indicator lamp does not light up when the electric drive system starts, the ABS is defective. An error code on the display also tells the rider that it is defective. If the indicator lamp does not go out after you set off or it lights up while you are riding, this means there is an error in the anti-blocking system. The anti-blocking system is then no longer active. The brake system itself remains functional. It is only the anti-blocking system control which no longer operates. If the ABS indicator lamp is lit, the ABS function is not active

- ▶ Adjust your riding to the current ambient conditions and your personal riding skills

- ▶ Remember that the anti-blocking system can make your braking distance longer.
- ▶ Reduce your speed on slippery ground. Brake in bursts and in good time.

Notice

The anti-blocking system indicator lamp may light up if the front and rear wheels are rotating at widely different speeds from one another – for example, if the rider cycles on the rear wheel only or if a wheel is rotating for an unusually long time without making contact with the ground (fitting stand). The anti-blocking system switches off in such cases.

- ▶ You need to stop and restart the pedelec (switch off and on again) to reactivate the anti-blocking system.

6.14 Suspension and damping

6.14.1 Adjusting the compression of the Fox fork

Only applies to pedelecs with this equipment

The compression adjuster makes it possible to make quick adjustments to the suspension behaviour of the fork to suit changes in terrain. It is intended for adjustments made during the ride.

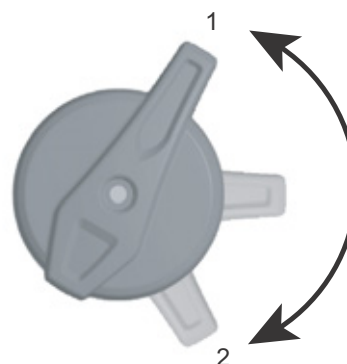

Figure 73: FOX compression adjuster with the OPEN (1) and HARD (2) positions

- ▶ Compression damping is lowest in the OPEN position, making the fork feel softer. Use the HARD position if you want the fork to feel stiffer and you are riding on soft ground. The lever positions between the OPEN and HARD positions enable fine adjustment of compression damping.

We recommend setting the lever of the compression adjuster to the OPEN mode position first.

6.14.2 Adjusting the compression of the Fox damper

Only applies to pedelecs with this equipment

The compression adjuster makes it possible to make quick adjustments to the suspension behaviour of the damper to suit changes in terrain. It is intended for adjustments made during the ride.



Figure 74: FOX compression adjuster on the rear frame damper with the OPEN (1), MEDIUM (2) and HARD (3) positions

- Use the OPEN position for rough descents, the MEDIUM position for rough terrain and the HARD position for efficient climbing. First set the compression adjuster to the OPEN position.

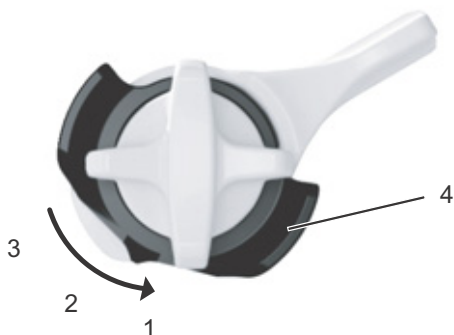

Figure 75: Fine adjustment of the OPEN position is made using the adjuster (4)

The FOX rear frame damper features fine adjustment for the OPEN position.

- ✓ We recommend that fine adjustments be made when the compression adjuster is in the MEDIUM or HARD position.
- Pull out the adjuster.
- Turn the adjuster to position 1, 2 or 3. Setting 1 is for the softest riding performance, whereas 3 is for the hardest.
- Press the adjuster in to lock in the setting.

6.14.3 Adjusting the compression of the Suntour fork

Only applies to pedelecs with this equipment

The compression adjuster makes it possible to make quick adjustments to the suspension behaviour of the fork to suit changes in terrain. It is intended for adjustments made during the ride.



Figure 76: Suntour compression adjuster with the OPEN (1) and LOCK (2) positions

- Compression damping is lowest in the OPEN position, making the fork feel softer. Use the LOCK position if you want the fork to feel stiffer and you are riding on soft ground. The lever positions between the OPEN and LOCK positions enable fine adjustment of compression damping.

We recommend setting the lever of the compression adjuster to the OPEN position first.

6.14.4 Adjusting the compression of a Suntour damper

Only applies to pedelecs with this equipment

The compression adjuster makes it possible to make quick adjustments to the suspension behaviour of the damper to suit changes in terrain. It should never be used while riding on rough terrain.



Figure 77: Suntour compression adjuster open (1)

- ▶ Use the OPEN position for rough descents and the LOCK position for efficient climbing. First set the compression adjuster to the OPEN position.



Figure 78: Suntour compression adjuster closed (2)

6.14.5 Adjusting the rebound in a Rock Shox damper

Only applies to pedelecs with this equipment

The rebound damper determines the speed at which the fork rebounds to full length after deflection. This speed affects the wheel's contact with the ground and thus has an influence on control and efficiency. The rear frame damper should rebound fast enough to sustain traction without producing an erratic or bumpy sensation. If rebound damping is too tight, the rear frame damper is unable to rebound fast enough before the next impact. The rebound damper for the rear wheel is located in the rear frame damper.



Figure 79: Setting the rebound damper strength on the rear frame damper setting wheel (1)

- ▶ Turn the setting wheel to the middle position.
 - ▶ Ride the pedelec over a small obstacle.
- ⇒ The ideal setting for the rebound damper has been achieved when the rebound movement of the rear wheel feels comparable to that of the front wheel.

- ▶ If the rear wheel bounces back much more quickly or slowly than the front wheel, change the setting by turning the setting wheel.

- Turn the setting wheel in an anti-clockwise direction to increase the rebound speed.
- Turn the setting wheel in a clockwise direction to decrease the rebound speed.

6.14.6 Adjusting the compression in a Rock Shox damper

Only applies to pedelecs with this equipment

The compression damper controls the speed at which the rear frame damper deflects during slow impact, such as smaller impacts or when the rider goes round a corner or shifts their weight. The damper improves control and efficiency.

If the compression damper is set too high, the suspension is too hard during impacts. The lever is used to set the compression damper.

- Turn the setting wheel in a clockwise direction (+) to decrease the deflection speed.
- ▶ Turn the setting wheel in an anti-clockwise direction (–) to increase the deflection speed.

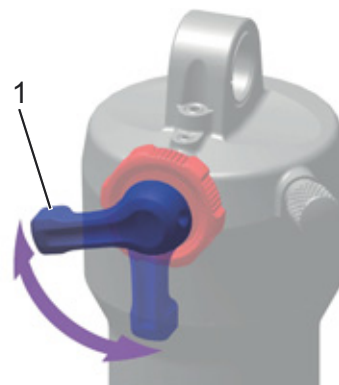

Figure 80: Setting the compression damper strength using the rear frame damper setting lever (1)

6.15 Gear shift

The selection of the appropriate gear is a prerequisite for a physically comfortable ride and making sure that the electric drive system functions properly. The ideal pedalling frequency is between 70 and 80 revolutions per minute.

- ▶ It is advisable to stop pedalling briefly when changing gears. This makes it easier to switch gears and reduces wear on the drivetrain.

6.15.1 Using the derailleur gears

Only applies to pedelecs with this equipment

The speed and range can be increased while applying the same force if you select the right gear. Use the derailleur gears.

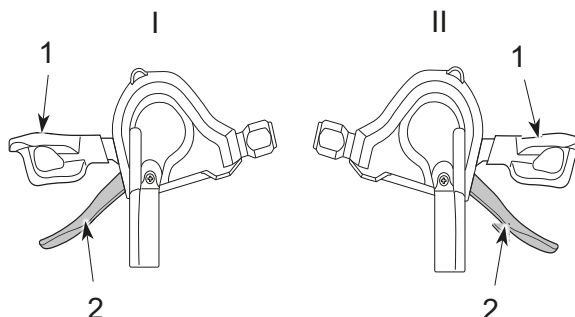

Figure 81: Down shifter (1) and up shifter (2) on the left (I) and right (II) gear shift

- ▶ Select the appropriate gear with the *shifter*.
- ⇒ The gear shift switches the gear.
- ⇒ The shifter returns to its original position.
- ▶ Clean the rear derailleur if the gear change blocks.

6.15.2 Using a hub gear

Only applies to pedelecs with this equipment



Crash caused by incorrect use

If the rider applies too much pressure on the pedals during a gear change and activates the shifter or changes several gears at a time, their feet may slip from the pedals. As a result, the pedelec may flip over or fall, which may cause injury.

Switching down several gears to a low gear may cause the twist grip outer sleeve to suddenly come off. This will not have an adverse effect on the twist grip's correct functioning since the outer guide returns to its original position after the gear change is complete.

- ▶ Apply little pressure on the pedals while changing gears.
- ▶ Never change more than one gear at a time.

Notice

The interior hub is not completely waterproof. If water gets into the hub, it may rust and the gear switch function may no longer function as a result.

- ▶ Never use the pedelec in places where water may get into the hub.

In rare cases, noises may be heard from the rear derailleur in the hub interior after a gear change. This is normal when gears are changed.

Do not detach the hub. If you need to detach it, contact your dealer.

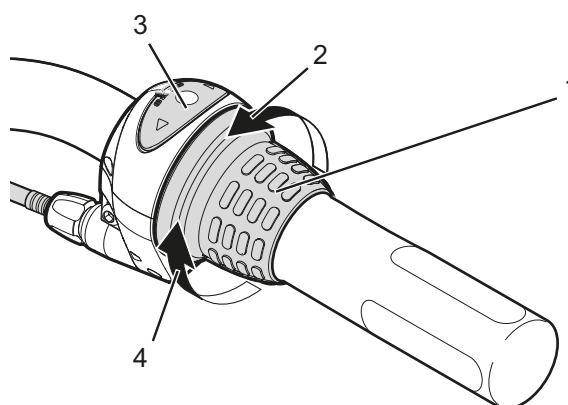

Figure 82: Example; Shimano Nexus gear shift twist grip (1) for the hub gear with its screen (3), the direction of rotation to switch up a gear (2) and the direction of rotation to switch down a gear (4)

- ▶ Turn the twist grip.
- ⇒ The gear shift switches the gear.
- ⇒ The number on the screen display shows the changed gear.

6.15.3 Use eShift

eShift refers to the integration of electronic gear shift systems into the pedelec system.

6.15.3.1 eShift with Shimano DI2 automatic hub gears

Only applies to pedelecs with this equipment

You can operate the automatic Shimano DI2 hub gears in manual mode or automatic mode. You used the shifter to change gears in manual mode. In automatic mode, the shift system changes gear automatically depending on the speed, pedalling power and pedalling frequency.

You will find how to switch from automatic to manual mode, depending on the shifter used, described in your operating instructions for your gear shift.

If you use the shifter when in automatic mode, the gear system will change to the next gear, but it will remain in automatic mode.

Manual gear changes in automatic mode influence shift behaviour in your gear system and adjust gear changes to your riding performance since it is a self-learning system.

If the system is switched on for the first time when a new, unused wheel is used, the system will learn the gears first. To do so, the automatic system changes to the highest/most difficult gear and then switches through all gears during the first ride. The new gear is shown briefly on the screen each time it is changed.

Since the drive unit detects the gear shift and consequently reduces motor assistance briefly, it is also possible to switch gears under load or on hills.

If the pedelec is brought to a halt from a speed greater than 10 km, the system can automatically switch back to a pre-set START GEAR.

You can set the START GEAR in the system settings.

6.15.3.2 eShift with manual Shimano DI2 hub gears

Only applies to pedelecs with this equipment

The new gear is shown briefly on the screen each time it is changed.

Since the drive unit detects the gear shift and consequently reduces motor assistance briefly, it is also possible to switch gears under load or on hills.

If the pedelec is brought to a halt from a speed greater than 10 km, the system can automatically switch back to a pre-set START GEAR.

You can set the START GEAR in the system settings.

6.15.3.3 eShift with Shimano DI2 automatic hub gears

Only applies to pedelecs with this equipment

The new gear is shown briefly on the screen each time it is changed. Since the drive unit detects the gear shift and consequently reduces motor assistance briefly, it is also possible to switch gears under load or on hills.

6.15.3.4 eShift with NuVinci H|Sync/enviolo with Optimized H|Sync

Only applies to pedelecs with this equipment

NUVINCI CADENCE mode allows you to reduce or increase the desired pedalling frequency using the **plus button** or **minus button** on the control panel.

If you hold the **plus button** or **minus button** down, you can increase or reduce the pedalling frequency in increments of five. The desired pedalling frequency is displayed on the screen.

NUVINCI GEAR mode allows you to switch between several specified transmissions using the **plus button** or **minus button** on the control panel. The selected transmission (gear) is displayed on the screen.

6.15.3.5 eShift with Rohloff E-14 Speedhub 500/14

Only applies to pedelecs with this equipment

The new gear is shown briefly on the screen each time it is changed.

Since the drive unit detects the gear shift and consequently reduces motor assistance briefly, it is also possible to switch gears under load or on hills.

If the pedelec is brought to a halt from a speed greater than 10 km/h, the system can automatically switch back to a pre-set START GEAR.

You can set the START GEAR in the system settings.

7 Cleaning and servicing

Cleaning check list

<input type="checkbox"/>	Clean the pedals	after each ride
<input type="checkbox"/>	Clean the suspension fork and, if necessary, rear frame damper	after each ride
<input type="checkbox"/>	Cleaning the battery	once a month
<input type="checkbox"/>	Chain (mainly tarmacked road)	every 250–300 km
<input type="checkbox"/>	Basic cleaning and preservation of all components	at least every six months
<input type="checkbox"/>	Clean the charger	at least every six months
<input type="checkbox"/>	Clean and lubricate the height-adjustable seat post	every six months

Maintenance check list

<input type="checkbox"/>	Check USB rubber cover position	before each ride
<input type="checkbox"/>	Check for tyre wear	once a week
<input type="checkbox"/>	Check for rim wear	once a week
<input type="checkbox"/>	Check tyre pressure	once a week
<input type="checkbox"/>	Check brakes for wear	once a month
<input type="checkbox"/>	Check electrical cables and Bowden cables for damage and ensure they are fully functional	once a month
<input type="checkbox"/>	Check chain tension	once a month
<input type="checkbox"/>	Check tension of the spokes	every three months
<input type="checkbox"/>	Check the gear shift setting	every three months
<input type="checkbox"/>	Check suspension fork and, if necessary, rear frame damper for wear and ensure fully functional	every three months
<input type="checkbox"/>	Check for wear on brake discs	at least every six months



Crash and falling caused by unintentional activation

There is a risk of injury if the drive system is activated unintentionally.

- ▶ Remove the battery before inspection.

The following servicing measures must be performed regularly. Servicing can be performed by the operator and rider. In case of any doubt, consult the specialist dealer.

7.1 Cleaning after each ride

Required tools and cleaning agents:

- Cloth
- Air pump
- Brush
- Water
- Dish-washing liquid
- Bucket

7.1.1 Cleaning the suspension fork

- ▶ Remove dirt and deposits on the stanchions and deflector seals with a damp cloth.
- ▶ Check the stanchions for dents, scratches, staining or leaking oil.
- ▶ Check the air pressure.
- ▶ Lubricate the dust seals and stanchions.

7.1.2 Cleaning the rear frame damper

- ▶ Remove dirt and deposits from the damper body with a damp cloth.
- ▶ Check rear frame damper for dents, scratches, staining or leaking oil.

7.1.3 Cleaning the pedals

- ▶ Clean with a brush and soapy water after riding through dirt or rain.
- ⇒ Service the pedals after cleaning.

7.2 Basic cleaning



Crash caused by brake failure

The braking effect may be unusually poor temporarily after cleaning, servicing or repairing the pedelec. This may cause a crash with injuries.

- ▶ Never apply care products or oil to the brake discs or brake linings, or the braking surfaces on the rims.
- ▶ After cleaning, servicing or repair, carry out a few test brake applications.

Notice

Water may enter into the inside of the bearings if you use a steam jet. This dilutes the lubricant inside, the friction increases and, as a result, the bearings are permanently damaged in the long term.

- ▶ Never clean the pedelec with a steam jet.

Greased parts, such as the seat post, the handlebars or the stem, may no longer be safely and reliably clamped.

- ▶ Never apply grease or oil to clamping sections.

Required tools and cleaning agents:

- Cloths
- Sponge
- Air pump
- Brush
- Toothbrush
- Paintbrush
- Watering can
- Bucket
- Water
- Dish-washing liquid
- Degreaser
- Lubricant
- Brake cleaner or spirit

- ✓ Remove battery and display before basic cleaning.

7.2.1 Cleaning the frame

- ▶ Soak dirt stains on the frame with dish-washing detergent if the dirt is thick and ingrained.
- ▶ After leaving it to soak for a time, remove the dirt and mud with a sponge, brush and toothbrush.
- ▶ Use a watering can or your hand to rinse the frame to finish off.
- ▶ Service the frame after cleaning.

7.2.2 Cleaning the stem

- ▶ Clean stem with a cloth and soapy water.
- ▶ Service the stem after cleaning.

7.2.3 Cleaning the rear frame damper

- ▶ Clean rear frame damper with a cloth and soapy water.

7.2.4 Cleaning the wheel



Crash caused by braking hard on rims

A rim can break and block the wheel if you brake hard. This may cause a crash with serious injuries.

Check rim *wear* on a regular basis.

- ▶ Check the tyres, rims, spokes and spoke nipples for any damage when cleaning the wheel.
- ▶ Use a sponge and a brush to clean the hub and spokes from the inside to the outside.
- ▶ Clean the rim with a sponge.

7.2.5 Cleaning the drive elements

- ▶ Spray the cassette, the chain wheels and the front derailleur with a degreasing agent.
- ▶ Clean coarse dirt with a brush after soaking for a short time.
- ▶ Wash down all parts with dish-washing detergent and a toothbrush.
- ▶ Service the drive elements after cleaning.

7.2.6 Cleaning the chain

Notice

- ▶ Never use aggressive (acid-based) cleaners, rust removers or degreasers when cleaning the chain.
 - ▶ Do not use chain cleaning devices or chain cleaning baths.
-
- ▶ Slightly dampen a brush with dish-washing liquid. Brush both sides of the chain.
 - ▶ Dampen a cloth with soapy water. Place the cloth on the chain.
 - ▶ Hold and apply slight pressure while slowly turning the rear wheel, so the chain passes through the cloth.
 - ▶ If the chain is still dirty afterwards, clean it with lubricant.
 - ▶ Service the chain after cleaning.

7.2.7 Cleaning the battery



Risk of fire and explosion due to penetration by water

The battery is only protected from simple spray water. Penetration by water can cause a short circuit. The battery may self-ignite and explode.

- ▶ Never clean the battery with a high-pressure water device, water jet or compressed air.
- ▶ Keep the contacts clean and dry.
- ▶ Never immerse the battery in water.
- ▶ Never use cleaning agents.
- ▶ Remove the battery from the pedelec before cleaning.

Notice

- ▶ Do not clean the battery with solvents, such as thinners, alcohol, oil and corrosion protection, or with cleaning agents.
-
- ▶ Clean the battery electrical connections with a dry cloth or brush only.
 - ▶ Wipe off the decorative sides with a damp cloth.

7.2.8 Cleaning the display

Notice

If water enters into the display screen, it will be permanently damaged.

- ▶ Never immerse the display in water.
 - ▶ Never clean with a high-pressure water device, water jet or compressed air.
 - ▶ Never use cleaning agents.
 - ▶ Remove the display from the pedelec before cleaning.
-
- ▶ Carefully clean the display with a damp, soft cloth.

7.2.9 Cleaning the drive unit



CAUTION

Burns from hot drive

The drive cooler can become extremely hot during use. Contact may cause burns.

- ▶ Leave the drive unit to cool before cleaning.

Notice

If water enters into the drive unit, the unit will be permanently damaged.

- ▶ Never immerse the drive unit in water.
 - ▶ Never clean with a high-pressure water device, water jet or compressed air.
 - ▶ Never use cleaning agents.
 - ▶ Never open.
-
- ▶ Carefully clean the drive unit with a damp, soft cloth.

7.2.10 Cleaning the brake

WARNING

Brake failure due to water penetration

The brake seals are unable to withstand high pressures. Damaged brakes can fail and cause an accident with injury.

- ▶ Never clean the pedelec with compressed air or a high-pressure water device.
 - ▶ Take great care when using a hosepipe. Never point the water jet directly at the seal section.
-
- ▶ Clean brake and brake discs with a brush, water and dish-washing detergent.
 - ▶ Clean brake discs thoroughly with brake cleaner or spirit.

7.3 Servicing

Required tools and cleaning agents:

- Cloths
- Toothbrushes
- Dish-washing liquid
- Care oil for frames
- Silicone or Teflon oil
- Acid-free lubricating grease
- Fork oil
- Chain oil
- Degreaser
- Spray oil
- Teflon spray

7.3.1 Servicing the frame

- ▶ Dry frame after cleaning.
- ▶ Spray with care oil. Clean off the care oil again after a short time.

7.3.2 Servicing the stem

- ▶ Apply silicone or Teflon oil to the stem shaft tube and the quick release lever pivot point.
- ▶ If you have speedlifter Twist, also apply oil to the unlocking bolt using the groove in the speedlifter body.
- ▶ Apply a little acid-free lubricant grease between the stem quick release lever and the sliding piece to reduce the quick release lever operating force.

7.3.3 Servicing the fork

- ▶ Treat the dust seals with fork oil.

7.3.4 Servicing the drive elements

- ▶ Spray the cassette, the chain wheels and the front derailleur with a degreasing agent.
- ▶ Clean coarse dirt with a brush after soaking for a short time.
- ▶ Wash down all parts with dish-washing detergent and a toothbrush.

7.3.5 Servicing the pedals

- ▶ Treat with spray oil after cleaning.

7.3.6 Servicing the chain

- ▶ Grease the chain thoroughly with chain oil after cleaning.

7.3.7 Servicing the drive elements

- ▶ Service front and rear derailleur articulated shafts and jockey wheels with Teflon spray.

7.4 Maintenance



Crash and falling caused by unintentional activation

There is a risk of injury if the drive system is activated unintentionally.

- ▶ Remove the battery before maintenance.

The following maintenance measures must be performed on a regular basis. They can be carried out by the operator and rider. In case of any doubt, consult the specialist dealer.

7.4.1 Wheel



Crash caused by braking hard on rims

A rim can break and block the wheel if you brake hard. This may cause a crash with serious injuries.

- ▶ Check rim *wear* on a regular basis.

Notice

If the tyre pressure is too low in the tyre, the tyre does not achieve its load bearing capacity. The tyre is not stable and may come off the rim.

If the tyre pressure is too high, the tyre may burst.

- ▶ Check the tyre pressure as per specifications
- ▶ *Adjust the tyre pressure* as necessary.
- ▶ Check *tyre wear*.
- ▶ Check the *tyre pressure*.
- ▶ Check the *rims* for wear.
 - The rims of a rim brake with invisible wear indicator are worn as soon as the wear indicator becomes visible in the area of the rim joint.
 - The rims with visible wear indicator are worn as soon as the black, all-round groove on the pad friction surface is no longer visible. We recommend that you also replace the *rims* with every second brake lining replacement.
- ▶ Check the tension of the spokes.

7.4.2 Checking the tyres

- ▶ Check the tyre wear. The tyre is worn if the anti-puncture protection or the carcass cords are visible.
- ⇒ A specialist dealer will need to change the tyre if it is worn.

7.4.3 Checking the rims

- ▶ Check the *rims* for wear. The rims are worn as soon as the black, all-round groove on the pad friction surface becomes invisible.
- ⇒ Worn rims must be replaced by a specialist dealer.
- ⇒ We recommend that you also replace the *rims* at the same time as every second brake lining replacement.

7.4.4 Check and correct tyre pressure

7.4.4.1 Dunlop valve



The tyre pressure cannot be measured on the simple Dunlop valve. The tyre pressure is therefore measured in the filling hose when pumping slowly with the bicycle pump.

It is recommendable to use a bicycle pump with a pressure gauge. The operating instructions for the bicycle pump must be adhered to.

- ▶ Unscrew and remove the valve cap.
- ▶ Connect the bicycle pump.
- ▶ Pump up the tyre slowly and pay attention to the tyre pressure in the process.
- ▶ Correct the tyre pressure according to specifications in the Pedelec pass.
- ▶ If the tyre pressure is too high, unfasten the union nut, let out air and tighten the union nut again.
- ▶ Remove the bicycle pump.
- ▶ Screw the valve cap tight.
- ▶ Screw the rim nut gently against the rim with the tips of your fingers.

7.4.4.2 Presta valve



✓ It is recommendable to use a bicycle pump with a pressure gauge. The operating instructions for the bicycle pump must be adhered to.

▶ Unscrew and remove the valve cap.

▶ Open the knurled nut around four turns.

▶ Carefully apply the bicycle pump so that the valve insert is not bent.

▶ Pump up the tyre slowly and pay attention to the tyre pressure in the process.

⇒ The tyre pressure has been adjusted as per the specifications.

▶ Remove the bicycle pump.

▶ Tighten the knurled nut with your fingers.

▶ Screw the valve cap tight.

Screw the rim nut gently against the rim with the tips of your fingers.

Screw the rim nut gently against the rim with the tips of your fingers.

7.4.4.3 Schrader valve



✓ It is recommendable to use a bicycle pump with a pressure gauge. The operating instructions for the bicycle pump must be adhered to.

▶ Unscrew and remove the valve cap.

▶ Connect the bicycle pump.

▶ Pump up the tyre slowly and pay attention to the tyre pressure in the process.

⇒ The tyre pressure has been adjusted as per the specifications.

▶ Remove the bicycle pump.

▶ Screw the valve cap tight.

▶ Screw the rim nut gently against the rim with the tips of your fingers.

7.4.5 Brake system



Crash caused by brake failure

Worn brake discs and brake linings, as well as a lack of hydraulic fluid in the brake cable, reduce the braking power. This may cause a crash with injuries.

▶ Check the brake disc, brake linings and the hydraulic brake system on a regular basis and replace if necessary.

The maintenance interval for the brake depends on the weather conditions and how frequent the pedelec is used. If the pedelec is used under extreme conditions such as rain, dirt or high mileage, maintenance must be performed more frequently.

7.4.6 Checking the brake linings for wear

Check brake linings after brake has been fully applied 1,000 times.

▶ Check that the brake linings are no less than 1.8 mm wide at any point and no less than 2.5 mm between the brake lining and supporting plate.

▶ Push brake lever and hold. In doing so, check the transport safety wear gauge can fit between the brake lining supporting plates.

⇒ The brake linings have not reached their wear limit. If they have, a specialist dealer will need to replace the brake linings.

7.4.7 Checking the pressure point

▶ Push brake lever and hold several times.

⇒ If you are unable to clearly detect the pressure point and it changes, a ZEG specialist dealer needs to vent the brake.

7.4.8 Checking the brake discs for wear

- ▶ Check that the brake disc is no less than 1.8 mm at any point.
- ⇒ The brake discs have not reached the wear limit. If they have, a specialist dealer will need to replace brake discs.

7.4.9 Electrical cables and brake cables

- ▶ Check all visible electrical cables and cables for damage. If the sheathing is compressed, for example, the pedelec will need to be removed from service until the cables have been replaced.
- ▶ Check all electrical cables and cables to make sure they are fully functional.

7.4.10 Gear shift

- ▶ Check the gear shift and the *shifter* or the *twist grip* setting and adjust it as necessary.

7.4.11 Stem

- ▶ The stem and quick release system should be inspected at regular intervals. The specialist dealer should adjust them if necessary.
- ▶ If the hexagon socket head screw is also loosened, the headset backlash also needs to be adjusted. Medium-strength thread locker, such as Loctite blue, then needs to be applied to the loosened screws and the screws tightened as per specifications.
- ▶ Check for wear and signs of corrosion (maintain with an oily cloth) and for oil leaks.

7.4.12 USB port

Notice

Any moisture which enters through the USB port may trigger a short circuit in the *display*.

- ▶ Regularly check the position of the *cover on the USB port* and adjust it as necessary.

7.4.13 Checking the belt and chain tension

Notice

Excessive chain tension increases wear.

If the chain tension is too low, there is a risk that the *chain* or the *drive belt* will slip off the *chain wheels*.

- ▶ Check the chain tension once a month.
- ▶ Check the chain tension in three or four positions, turning the crank a full revolution.
- ▶ If the *chain* can be pushed more than 2 cm, the *chain* or *drive belt* will need to be tensioned again by the specialist dealer.
- ▶ If the *chain* or the *drive belt* can only be pushed up and down less than 1 cm, you will need to slacken the *chain* or the *drive belt*.
- ⇒ The optimum chain tension is achieved if the *chain* or the *drive belt* can be pushed a maximum of 2 cm in the middle between the pinion and the toothed wheel. The crank must also turn without resistance.
- ⇒ If a hub gear is featured, the rear wheel must be pushed backwards or forwards to tighten the chain. This should be done by a specialist only.

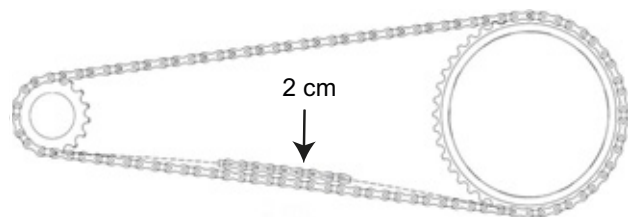

Figure 83: Checking the chain tension

7.4.14 Checking the handlebar grip position

- ▶ Check the handlebar grip is firmly in position.



8 Maintenance

WARNING

Injury due to damaged brakes

Special tools and specialist knowledge are required to repair the brakes. Incorrect or unauthorised assembly can damage the brakes. This may lead to an accident with injuries.

- ▶ Only specialist dealers may carry out repairs on brakes.

Never carry out work or changes (such as dismantling, sanding or painting) which are not explicitly allowed and described in the brake user manual.

Injury to the eyes

Problems may arise if the settings are not made properly and you may sustain serious injuries as a result.

Always wear safety glasses to protect your eyes when carrying out maintenance work such as replacing components.

CAUTION

Crash and falling caused by unintentional activation

There is a risk of injury if the drive system is activated unintentionally.

- ▶ Remove the battery before inspection.

Crash caused by material fatigue

If the service life of a component has expired, the component may suddenly fail. This may cause a crash with injuries.

- ▶ Have the specialist dealer carry out basic cleaning of the pedelec every six months, preferably at the same time as the required servicing work.

CAUTION

Hazard for the environment due to toxic substances

The brake system contains toxic and environmentally harmful oils and lubricants. Such fluids will contaminate if they enter the sewers or groundwater.

- ▶ Dispose of lubricants and oils left over after repairs in an environmentally responsible way
- ▶ in accordance with statutory regulations.

Notice

The motor is maintenance-free and may only be opened by qualified specialist personnel.

- ▶ Never open the motor.

You must have the specialist dealer perform maintenance every six months as a minimum. This is the only way to ensure that the pedelec remains safe and fully functional.

Special tools, special lubricants and knowledge of suspension components are required to maintain and repair brake discs as well as vent brakes or replace brake discs. The pedelec may become damaged if the stipulated maintenance intervals and procedures are not carried out. That is why only specialist dealers may carry out maintenance.

- ▶ The retailer will check the pedelec based on the maintenance table in the appendix.
- ▶ The specialist dealer will inspect the pedelec for any signs of material fatigue during basic cleaning.
- ▶ The specialist dealer will check the software version of the drive system and update it. The electrical connections are checked, cleaned and preservative agent is applied. The electrical cables are inspected for damage.
- ▶ The specialist dealer will dismantle and clean the entire suspension fork interior and exterior. They will clean and lubricate the dust seals and slide bushings, check the torques and adjust the fork to the rider's preferred position. They will also replace the sliding collar if the

clearance is too great (more than 1 mm on the fork bridge).

- ▶ The specialist dealer will fully inspect the interior and exterior of the rear frame damper, overhaul the rear frame damper, replace all air seals on air forks, overhaul the air suspension, change the oil and replace the dust wipers.
- ▶ They will pay particular attention to rim and brake wear. The spokes are re-tightened in accordance with the findings.

8.1 Axle with quick release

CAUTION

Crash caused by unfastened quick release

A faulty or incorrectly installed quick release may become caught in the brake disc and block the wheel. This will cause a crash.

- ▶ Install the front wheel quick release lever on the opposite side to the brake disc.

Crash caused by faulty or incorrectly installed quick release

The brake disc becomes very hot during operation. Parts of the quick release may become damaged as a result. The quick release comes loose. This will cause a crash with injuries.

- ▶ The front wheel quick release lever and the brake disc must be situated on opposite sides.

Crash caused by incorrectly set clamping force

Excessively high clamping force will damage the quick release and cause it to lose its function.

Insufficient clamping force will cause a detrimental transmission of force. The suspension fork or the frame may break. This will cause a crash with injuries.

- ▶ Never fasten a quick release using a tool (e.g. hammer or pliers).

Only use the clamping lever with the specified set clamping force.

8.1.1 Checking the quick release

- ▶ Check the position and clamping force of the quick release lever. The quick release lever must be flush with the lower housing. You must be able to see a slight impression on the palm of your hand when you close the quick release lever.



Figure 84: Adjusting the quick release clamping force

- ▶ Use a 4 mm hexagon socket spanner to adjust the clamping lever clamping force if required. Afterwards, check the quick release lever position and clamping force.

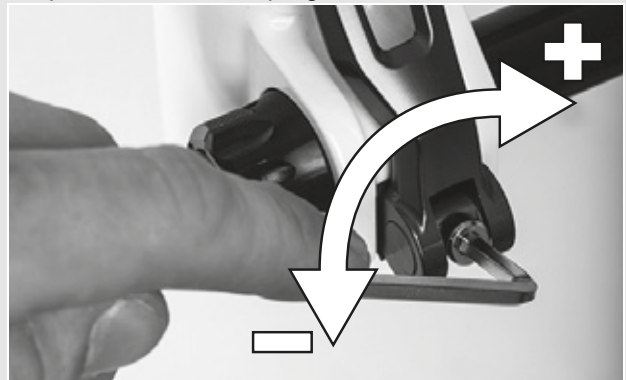

Figure 85: Adjusting the quick release clamping force

8.2 Adjusting the gear shift

If you cannot select the gears effortlessly, you will need to adjust the setting for the shift cable tension.

- ▶ Carefully pull the *adjusting sleeve* away from the shifter housing, turning it as you do so.
- ▶ Check the gear shift function after each adjustment.

8.2.1 Cable-operated gear shift, single-cable

Only applies to pedelecs with this equipment

- For a smooth gear shift, adjust the adjusting sleeves on the shifter housing.



Figure 86: Adjusting sleeve (1) for the single-cable, cable-operated gear shift with shifter housing (2), example

8.2.2 Cable-operated gear shift, dual-cable

Only applies to pedelecs with this equipment

- For a smooth gear shift, set the adjusting sleeves underneath the chain stay on the frame.
- The shift cable has around 1 mm play when it is pulled out gently.

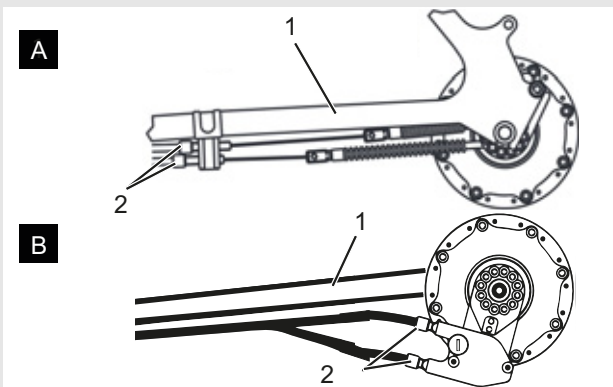

Figure 87: Adjusting sleeves (2) on two alternative versions (A and B) of a dual-cable, cable-operated gear shift on the chain stay (1)

8.2.3 Cable-operated twist grip, dual-cable

Only applies to pedelecs with this equipment

- For a smooth gear shift, set the adjusting sleeves on the shifter housing.
- ⇒ There is noticeable play of around 2–5 mm (1/2 gear) when twisting the twist grip.

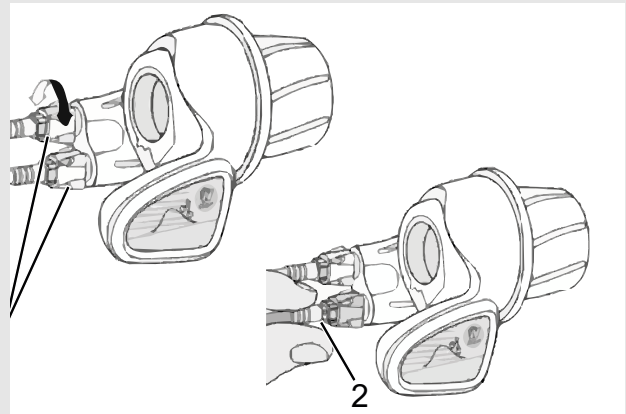

Figure 88: Twist grip with adjusting sleeves (1) and play of the gear shift (2)

9 Troubleshooting, fault clearance and repair

9.1 Troubleshooting and fault clearance



Risk of fire and explosion due to faulty battery

The safety electronics may fail if the battery is damaged or faulty. The residual voltage can cause a short circuit. Batteries may self-ignite and explode.

- ▶ Batteries with external damage must be removed from service immediately.
- ▶ Never allow damaged batteries to come into contact with water.
- ▶ If a battery is dropped or struck but shows no signs of external damage, remove it from service and observe it for at least 24 hours.
- ▶ Faulty batteries are hazardous goods. Dispose of faulty batteries properly and as quickly as possible.
- ▶ Store in a dry place until disposal. Never store in the vicinity of flammable substances.

Never open or repair the battery.

The components of the drive system are checked constantly and automatically. If an error is detected the corresponding error code will appear on the *display screen*. Depending on the type of error, the drive will also be automatically switched off.

9.1.1 The drive system or display do not start up

If the display and/or the drive system do not start up, proceed as follows:

- ▶ Check whether the battery is switched on. If not, start the battery.
- ⇒ Contact specialist dealer if the battery level indicator LEDs do not light up.
- ▶ If the LEDs on the battery level indicator light up, but the drive system does not start up, remove the battery.

- ▶ Insert the battery.
- ▶ Start the drive system.
- ▶ If the drive system does not start up, remove the battery.
- ▶ Clean all the contacts with a soft cloth.
- ▶ Insert the battery.
- ▶ Start the drive system.
- ▶ If the drive system does not start up, remove the battery.
- ▶ Fully charge the battery.
- ▶ Insert the battery.
- ▶ Start the drive system.
- ▶ If the drive system does not start up, remove the display.
- ▶ Fasten the display.
- ▶ Start the drive system.
- ▶ Contact your specialist dealer if the drive system does not start up.

9.1.2 Error messages

If an error message is displayed, run through the following actions:

- ▶ Make a note of the system message.
- ▶ Shut off and re-start the drive system.
- ▶ If the system message is still displayed, remove and then re-insert the battery.
- ▶ Re-start the drive system.
- ▶ If the system message is still displayed, contact your specialist dealer.

9.2 Repair

Special knowledge and tools are required for many repairs. That is why only a specialist dealer may perform repairs such as:

- Replacing tyres and rims
- Replacing brake pads and brake linings
- Replacing and tensioning the chain.

9.2.1 Use original parts and lubricants only

The individual pedelec parts have been carefully selected and matched to one other.

Only original parts and lubricants must be used for maintenance and repair.

The constantly updated accessory approval and parts list are Section 11, Documents and Drawings.

9.2.2 Replacing the lighting

- ▶ Only use components of the respective power class for replacement.

9.2.3 Setting the headlight

- ▶ The *headlight* must be set, so that its light beam shines on the road 10 m in front of the pedelec.

10 Recycling and disposal

WARNING

Risk of fire and explosion

The safety electronics on a damaged or faulty battery may fail. The residual voltage can cause a short circuit. The battery may self-ignite and explode.

- ▶ Remove battery with any external damage from service immediately and never recharge it.
- ▶ If the battery becomes deformed or begins to smoke, keep at a safe distance, disconnect the power supply at the socket, and notify the fire service immediately.
- ▶ Never extinguish damaged batteries with water or allow them to come into contact with water.
- ▶ Faulty batteries are hazardous goods. Dispose of faulty batteries properly as quickly as possible.
- ▶ Store in a dry place until disposal. Never store in the vicinity of flammable substances.

Never open or repair the battery.

CAUTION

Chemical burns to the skin and eyes

Liquids and vapours may leak from a damaged or faulty battery. They can irritate the airways and cause burns.

- ▶ Avoid contact with leaked liquids.
- ▶ Immediately consult a doctor in case of contact with the eyes or any discomfort.
- ▶ In case of contact with the skin, rinse off immediately with water.
- ▶ Ventilate the room well.

CAUTION

Hazard for the environment

The fork, rear frame damper and hydraulic brake system contain toxic and environmentally harmful oils and lubricants. Such fluids will contaminate if they enter the sewers or groundwater.

- ▶ Dispose of lubricants and oils in an environmentally responsible way in accordance with statutory regulations.



This device is marked according to the European Directive 2012/19/EU on waste electrical and electronic equipment – WEEE and the European Directive 2006/66/EC on accumulators.

The directive provides the framework for the return and recycling of used devices across the EU. As a consumer, you are legally required to return all used batteries of any type. It is forbidden to dispose of batteries in domestic waste. The manufacturer is obliged to take back used and old batteries free of charge as per Section 9 German Batteries Act. You thus meet statutory obligations and help to protect the environment. The pedelec, battery, motor, display screen and charger are recyclable materials. You must dispose of and recycle them separately from the domestic waste in compliance with applicable statutory regulations. Sorted waste collection and recycling saves on raw material reserves and ensures that all the regulations for health and environmental protection are met when the product and/or the battery are recycled.

- ▶ Never dismantle the pedelec, batteries or charger for disposal.
- ▶ The pedelec, display screen, the unopened and undamaged battery and the charger can be returned to any specialist dealer free of charge. Depending on the region, further disposal options may be available.

Store the individual parts of the decommissioned pedelec in a dry place, free from frost, where they are protected from direct sunlight.

11 Documents

11.1 Parts list

There was no information relating to a parts list yet at the time of going to press. You'll find the information in the latest *operating instructions*.

11.2 Assembly report

Date:

Frame number:

Components	Description		Criteria		Measures if rejected
	Assembly/inspection	Tests	Acceptance	Rejection	
Front wheel	Assembly		O.K.	Loose	Adjust quick release
Kickstand	Check mount fastening	Functional check	O.K.	Loose	Retighten screws
Tyres		Tyre pressure check	O.K.	Tyre pressure too low/too high	Adjust tyre pressure
Frame	Check for damage – fracture, scratches		O.K.	Damage detected	<i>Take out of operation, new frame</i>
Handles, coverings	Check mount fastening		O.K.	Not provided	Retighten screws, new handles or coverings as specified in parts list
Handlebars, stem	Check mount fastening		O.K.	Loose	Retighten screws; new stem as specified in parts list if necessary
Steering headset	Check for damage	Functional check	O.K.	Loose	Retighten screws
Saddle	Check mount fastening		O.K.	Loose	Retighten screws
Seat post	Check mount fastening		O.K.	Loose	Retighten screws
Protective plate	Check mount fastening		O.K.	Loose	Retighten screws
Pannier rack	Check mount fastening		O.K.	Loose	Retighten screws
Attachments	Check mount fastening		O.K.	Loose	Retighten screws
Bell		Functional check	O.K.	No ring, too quiet, missing	New bell as specified in the parts list
Suspension elements					
Fork, suspension fork	Check for damage		O.K.	Damage detected	New fork as specified in the parts list
Rear frame damper	Check for damage		O.K.	Damage detected	New fork as specified in the parts list
Suspension seat post	Check for damage		O.K.	Damage detected	New fork as specified in the parts list
Brake system					
Brake lever	Check mount fastening		O.K.	Loose	Retighten screws
Brake fluid	Check fluid level		O.K.	Too little	Refill with brake fluid; new brake hoses if damaged
Brake linings	Check brake linings, brake discs or rims for damage		O.K.	Damage detected	New brake linings, brake discs or rims
Back-pedal brake braking armature	Check mount fastening		O.K.	Loose	Retighten screws
Light system					
Rechargeable battery	First examination		O.K.	Error message	<i>Take out of service</i> ; contact battery manufacturer, new battery
Light cabling	Connections, correct wiring		O.K.	Cable defective, no light	New cabling
Rear light	Side light	Functional check	O.K.	No constant light	<i>Take out of service</i> ; new rear light as specified in parts list; replace battery if necessary
Front light	Side light, daytime riding light	Functional check	O.K.	No constant light	<i>Take out of service</i> ; new front light as specified in parts list; replace battery if necessary
Reflectors	All complete, state, fastening		O.K.	Damaged or not all complete	New reflectors

Components	Description		Criteria		Measures if rejected
Drive/gear shift					
Chain/cassette/ pinion/chainring	Check for damage		O.K.	Damage	Refasten if necessary or replace as specified in parts list
Chain guard/spoke guard	Check for damage		O.K.	Damage	Replace as specified in parts list
Bottom bracket axle/ crank	Check mount fastening		O.K.	Loose	Retighten screws
Pedals	Check mount fastening		O.K.	Loose	Retighten screws
Shifter	Check mount fastening	Functional check	O.K.	Loose	Retighten screws
Shift cables	Check for damage	Functional check	O.K.	Loose or defective	Adjust shift cables; new shift cables if necessary
Front derailleur	Check for damage	Functional check	O.K.	Gear shift difficult or not possible	Adjust
Rear derailleur	Check for damage	Functional check	O.K.	Gear shift difficult or not possible	Adjust
Electric drive					
Display	Check for damage	Functional check	O.K.	No screen display, defective screen display	Restart, test battery, new software, or new display; <i>take out of service</i> ,
Electric drive control panel	Check for damage	Functional check	O.K.	No response	Restart; contact control panel manufacturer, new control panel
Tachometer		Speed measurement	O.K.	Pedelec travelling 10% too fast/slow	Shut off pedelec until source of fault is found
Cabling	Visual inspection		O.K.	Failure in system, damage, kinked cables	New cabling
Battery mount	Firmly in position, lock, contacts	Functional check	O.K.	Loose; lock doesn't close, no contacts	New battery mount
Motor	Visual inspection and mount		O.K.	Damage, loose	Refasten motor, contact motor manufacturer, new motor
Software	Check version		In latest version	Not latest version	Import update

Technical inspection, checking safety, test ride

Components	Description		Criteria		Measures if rejected
	Assembly/inspection	Tests	Acceptance	Rejection	
Brake system		Functional check	O.K.	No full braking; braking distance too long	Locate defective part in brake system and correct
Gear shift under operating load		Functional check	O.K.	Problems when shifting gear	Readjust gear shift
Suspension components (fork, shock absorber, seat post)		Functional check	O.K.	Suspension too deep or no longer exists	Locate defective component and correct
Electric drive		Functional check	O.K.	Loose connection, problems when riding, accelerate	Locate defective part in electric drive and correct
Light system		Functional check	O.K.	No continuous light, too bright	Locate defective part in light system and correct
Test ride			No strange noises.	Strange noises.	Locate source of noise and correct

Date	
Fitter's name:	
Final inspection by workshop manager	

11.3 Maintenance log

Diagnosis and documentation of current status

Date:

Frame number:

Components	Frequency	Description			Criteria		Measures if rejected
		Inspection	Tests	Maintenance	Acceptance	Rejection	
Front wheel	6 months	Assembly			O.K.	Loose	Adjust quick release
Kickstand	6 months	Check mount fastening	Functional check		O.K.	Loose	Retighten screws
Tyres	6 months		Tyre pressure check		O.K.	Tyre pressure too low/too high	Adjust tyre pressure
Frame	6 months	Check for damage – fracture, scratches			O.K.	Damage detected	Shut off pedelec; new frame
Handles, coverings	6 months	Wear; check if fastened securely			O.K.	Not provided	Retighten screws, new handles or coverings as specified in parts list
Handlebars, stem	6 months	Check mount fastening			O.K.	Loose	Retighten screws; new stem as specified in parts list if necessary
Steering headset	6 months	Check for damage	Functional check	Lubricating and adjustment	O.K.	Loose	Retighten screws
Saddle	6 months	Check mount fastening			O.K.	Loose	Retighten screws
Seat post	6 months	Check mount fastening			O.K.	Loose	Retighten screws
Protective plate	6 months	Check mount fastening			O.K.	Loose	Retighten screws
Pannier rack	6 months	Check mount fastening			O.K.	Loose	Retighten screws
Attachments	6 months	Check mount fastening			O.K.	Loose	Retighten screws
Bell	6 months		Functional check		O.K.	No ring, too quiet, missing	New bell as specified in the parts list
Suspension elements							
Fork, suspension fork	To manufacturer's specifications	Check for damage – corrosion, fracture		Maintenance as specified by manufacturer Lubrication, oil change as specified by manufacturer	O.K.	Damage detected	New fork as specified in the parts list
Rear frame damper	To manufacturer's specifications	Check for damage – corrosion, fracture		Maintenance as specified by manufacturer Lubrication, oil change as specified by manufacturer	O.K.	Damage detected	New fork as specified in the parts list
Suspension seat post	To manufacturer's specifications	Check for damage		Maintenance as specified by manufacturer	O.K.	Damage detected	New fork as specified in the parts list
Brake system							
Brake lever	6 months	Check mount fastening			O.K.	Loose	Retighten screws
Brake fluid	6 months	Check fluid level		Depending on time of year	O.K.	Too little	Top up brake fluid; <i>take out of service</i> if damaged; new brake hoses
Brake linings	6 months	Check brake linings, brake discs or rims for damage			O.K.	Damage detected	New brake linings, brake discs or rims
Back-pedal brake braking armature	6 months	Check mount fastening			O.K.	Loose	Retighten screws
Brake system	6 months	Check mount fastening		Functional check	O.K.	Loose	Retighten screws

Components	Frequency	Description			Criteria		Measures if rejected
		Inspection	Tests	Maintenance	Acceptance	Rejection	
Light system							
Rechargeable battery		First examination			O.K.	Error message	Contact battery manufacturer; <i>take out of service</i> , new battery
Light cabling		Connections, correct wiring			O.K.	Cable defective, no light	New cabling
Rear light		Side light	Functional check		O.K.	No constant light	New rear light as specified in parts list; replace battery if necessary
Front light		Side light, daytime riding light	Functional check		O.K.	No constant light	New front light as specified in parts list; replace battery if necessary
Reflectors		All complete, state, fastening			O.K.	Damaged or not all complete	New reflectors
Drive/gear shift							
Chain/cassette/pinion/chainring		Check for damage			O.K.	Damage	Refasten if necessary or replace as specified in parts list
Chain guard/spoke guard		Check for damage			O.K.	Damage	Replace as specified in parts list
Bottom bracket axle/crank		Check mount fastening			O.K.	Loose	Retighten screws
Pedals		Check mount fastening			O.K.	Loose	Retighten screws
Shifter		Check mount fastening	Functional check		O.K.	Loose	Retighten screws
Shift cables		Check for damage	Functional check		O.K.	Loose or defective	Adjust shift cables; new shift cables if necessary
Front derailleur		Check for damage	Functional check		O.K.	Gear shift difficult or not possible	Adjust
Rear derailleur		Check for damage	Functional check		O.K.	Gear shift difficult or not possible	Adjust
Electric drive							
Display		Check for damage	Functional check		O.K.	No screen display, defective screen display	Restart, test battery, new software, or new display; <i>take out of service</i> ,
Electric drive control panel		Check drive for damage	Functional check		O.K.	No response	Restart; contact control panel manufacturer, new control panel
Tachometer			Speed measurement		O.K.	Pedelec travelling 10% too fast/slow	Shut off pedelec until source of fault is found
Cabling		Visual inspection			O.K.	Failure in system, damage, kinked cables	New cabling
Battery mount		Firmly in position, lock, contacts	Functional check		O.K.	Loose; lock doesn't close, no contacts	New battery mount
Motor		Visual inspection and mount			O.K.	Damage, loose	Refasten motor, contact motor manufacturer, new motor; <i>take out of service</i>
Software		Check version			In latest version	Not latest version	Import update

Technical inspection, checking safety, test ride

Components	Description	Criteria		Measures if rejected	
Assembly/inspection	Tests	Accept- ance	Rejection		
Brake system		Functional check	O.K.	No full braking; braking distance too long	Locate defective part in brake system and correct
Gear shift under operating load		Functional check	O.K.	Problems when shifting gear	Readjust gear shift
Suspension components (fork, shock absorber, seat post)		Functional check	O.K.	Suspension too deep or no longer exists	Locate defective component and correct
Electric drive		Functional check	O.K.	Loose connection, problems when riding, accelerate	Locate defective part in electric drive and correct
Light system		Functional check	O.K.	No continuous light, too bright	Locate defective part in light system and correct
Test ride			No strange noises.	Strange noises.	Locate source of noise and correct

Date	
Fitter's name:	
Final inspection by workshop manager	

11.4 Charger operating instructions

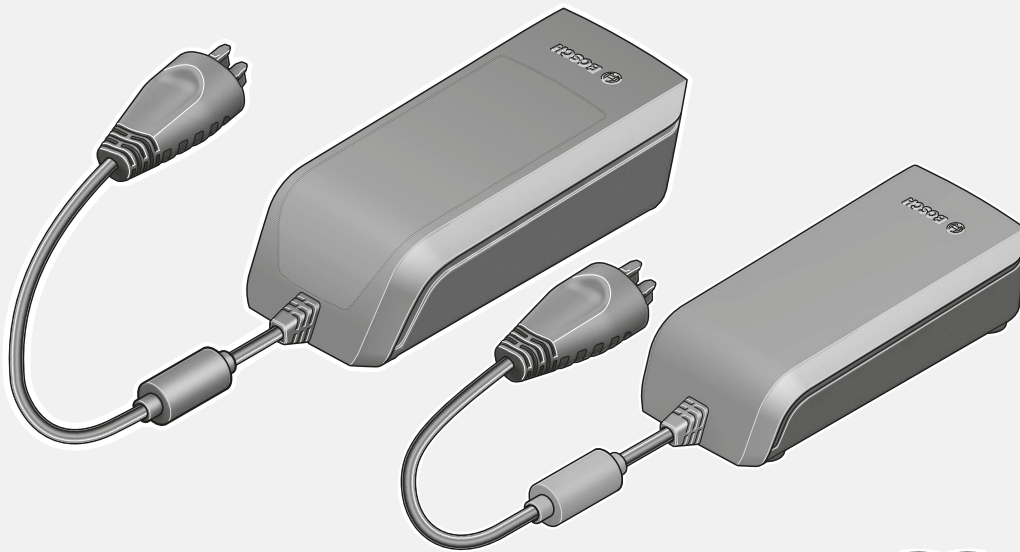

Charger

BCS220 | BCS230 | BCS250



BOSCH

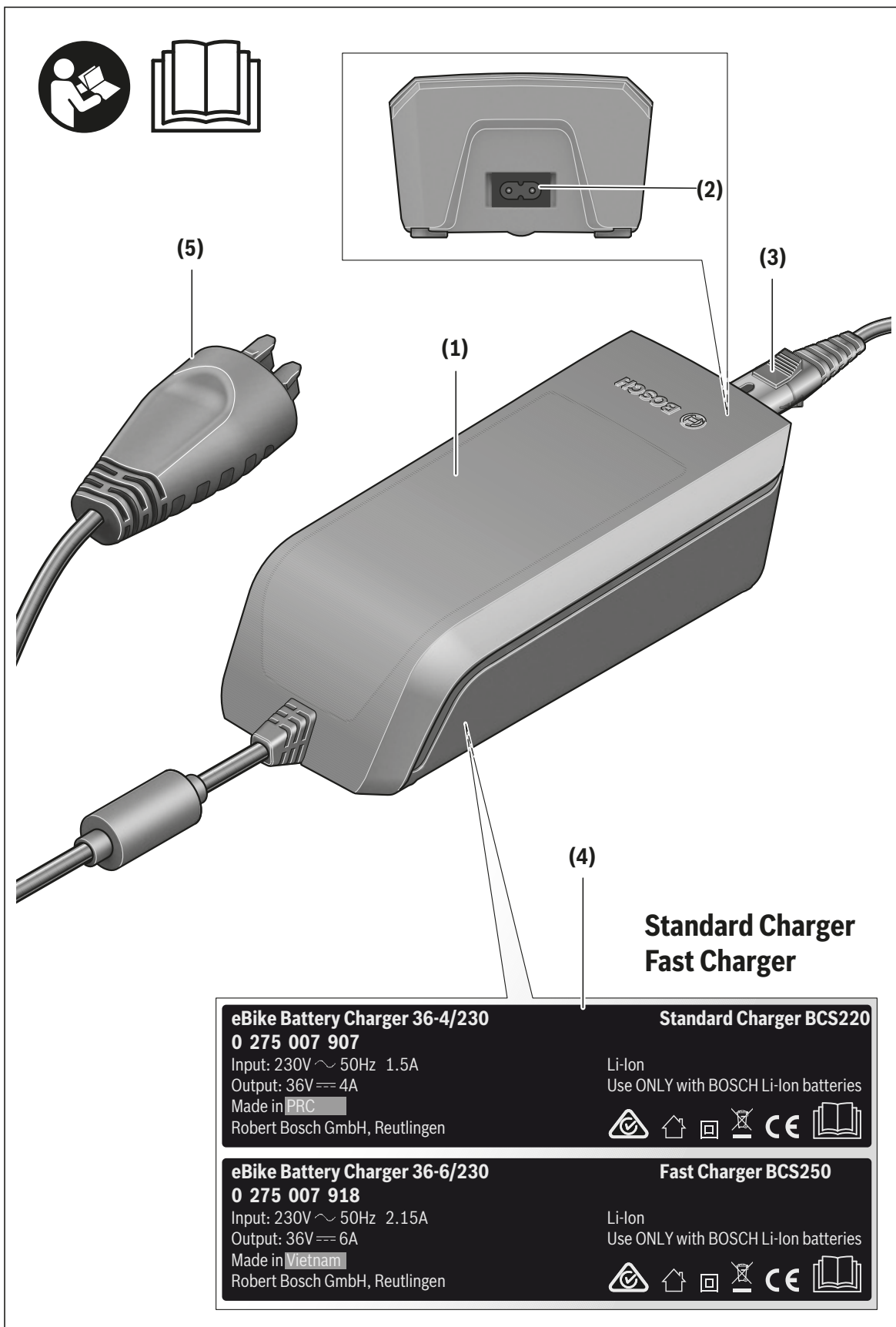

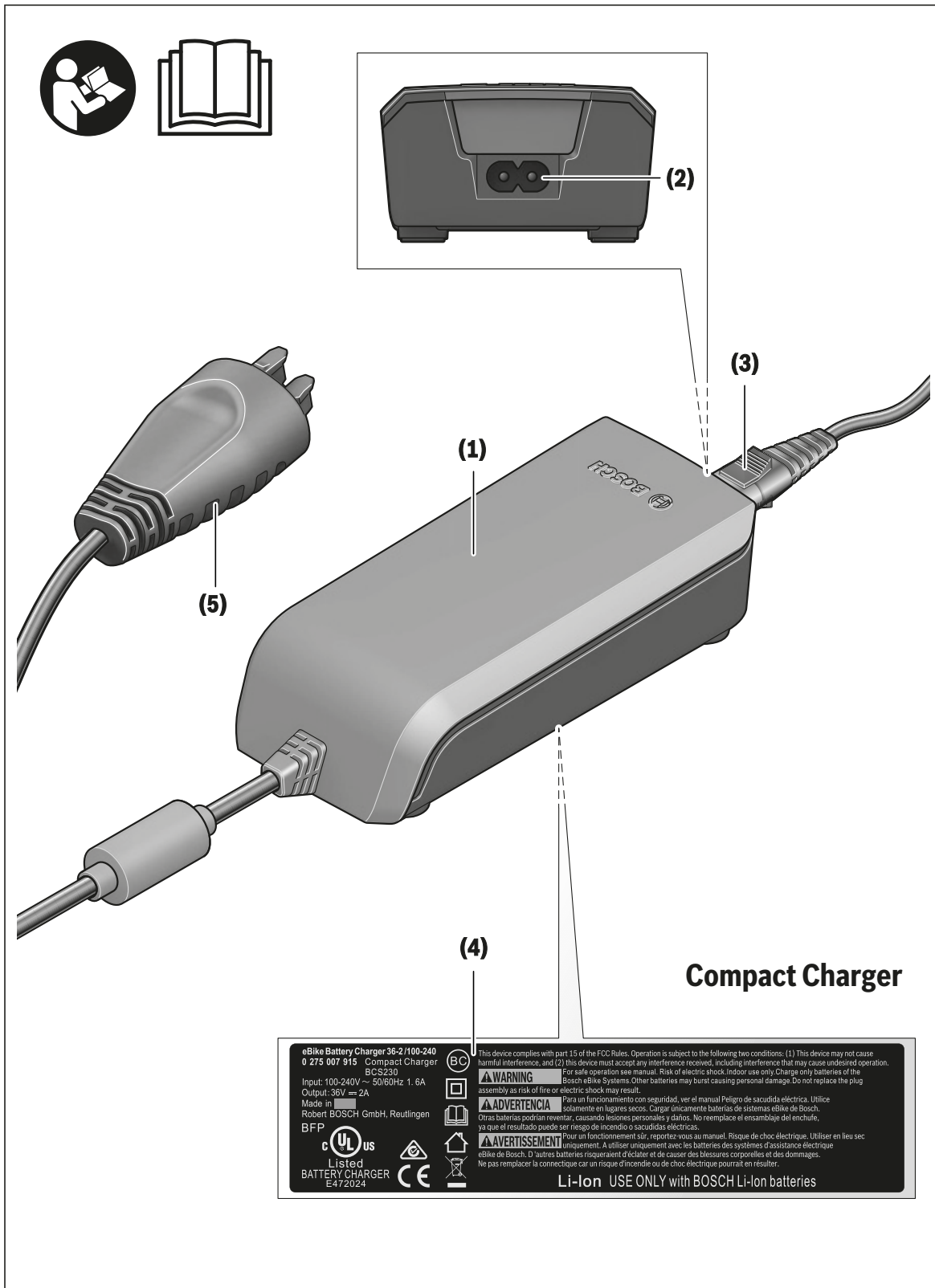

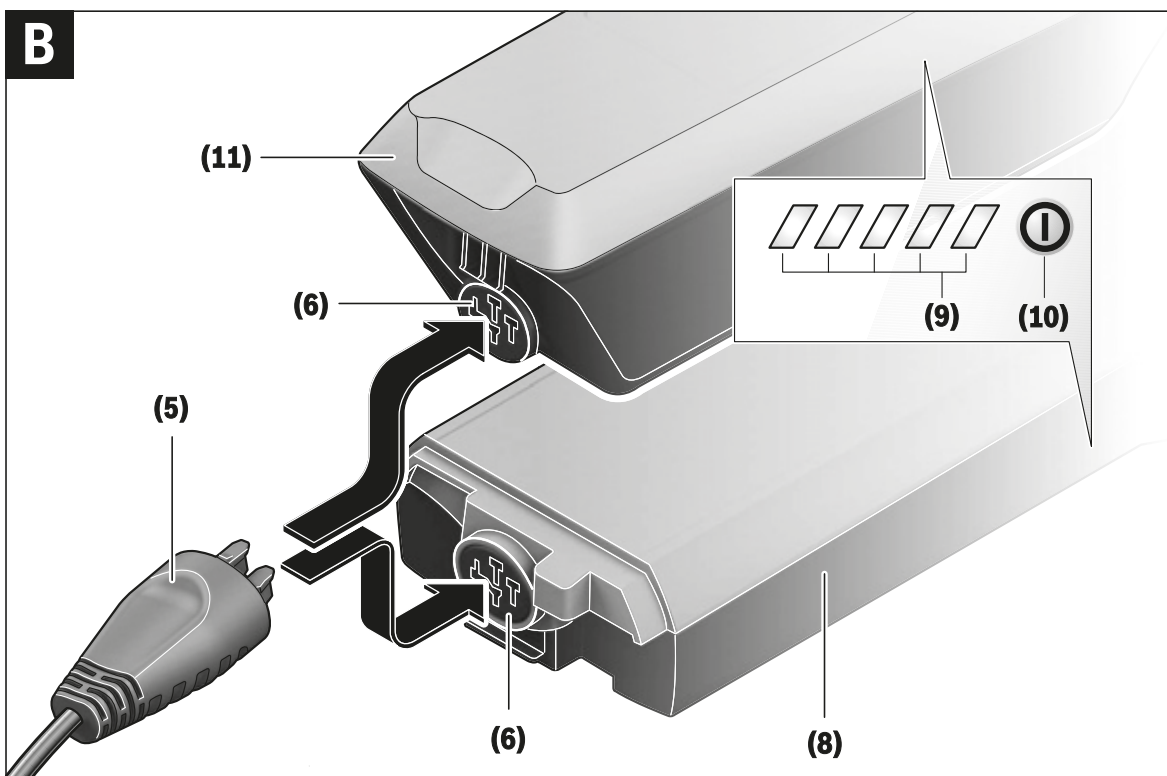
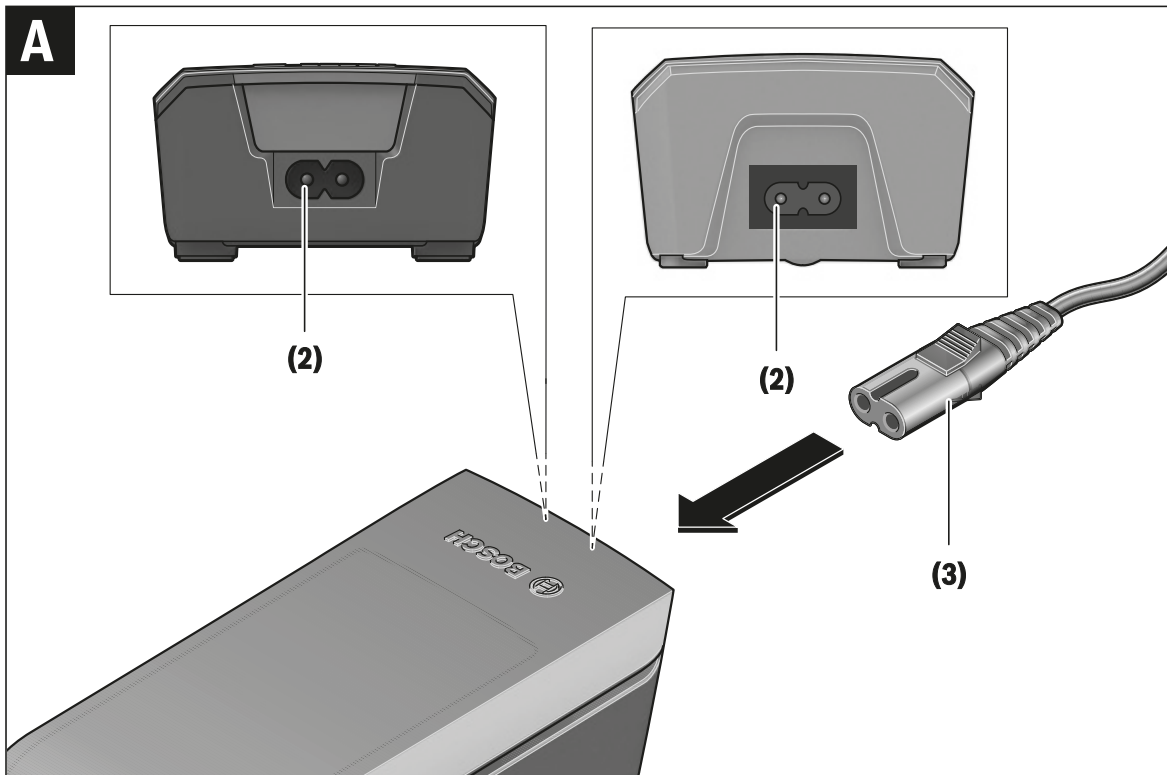

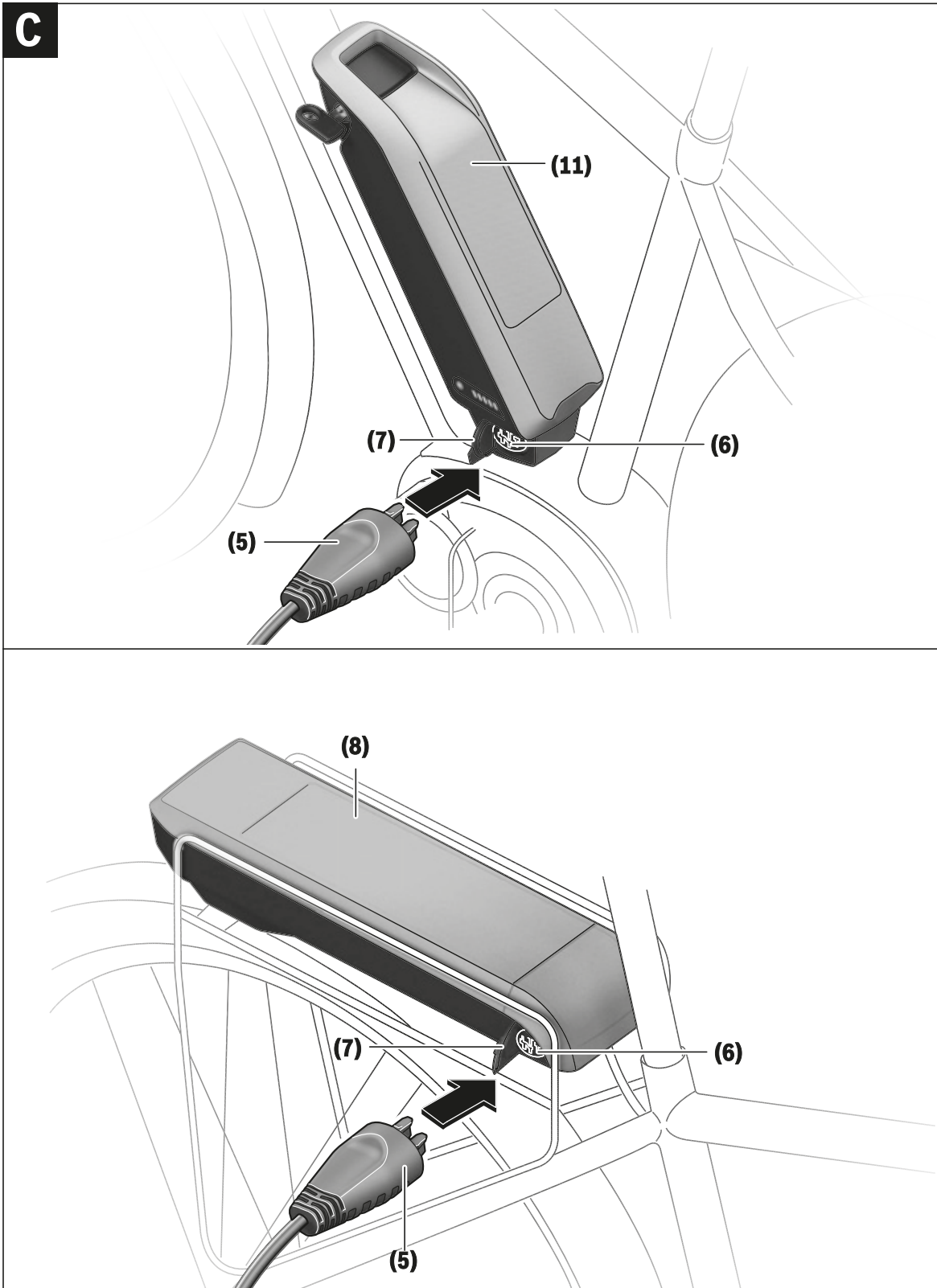

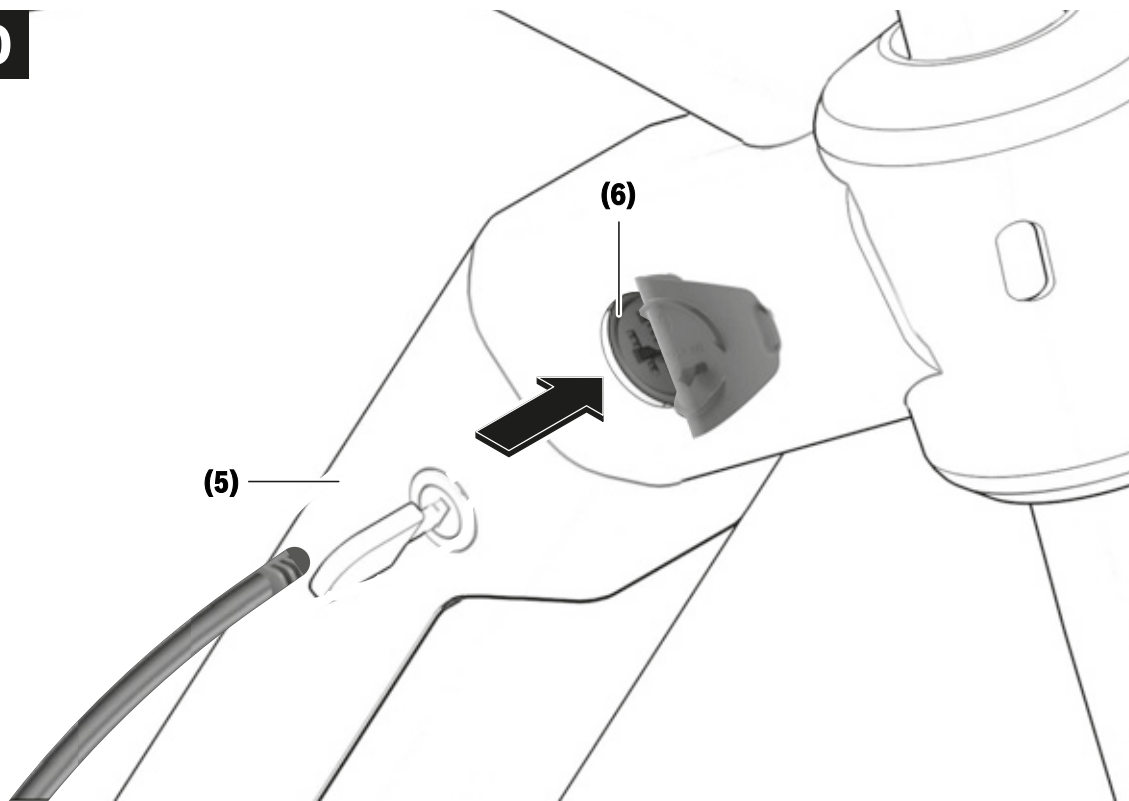
D

Safety instructions



Read all the safety and general instructions. Failure to observe the safety and general instructions may result in electric shock,

fire and/or serious injury

Save all safety warnings and instructions for future reference.

The term **battery** is used in these instructions to mean all original Bosch eBike rechargeable battery packs.



Do not expose the charger to rain or wet conditions. If water enters a charger, there is a risk of electric shock

- ▶ **Charge only Bosch lithium-ion batteries that are approved for use in eBikes. The battery voltage must match the battery charging voltage of the charger.** Otherwise there is a danger of fire and explosion.
- ▶ **Keep the charger clean.** Dirt poses a risk of electric shock
- ▶ **Always check the charger, cable and plug before use. Stop using the charger if you discover any damage. Do not open the charger.** Damaged chargers, cables and plugs increase the risk of electric shock
- ▶ **Do not operate the charger on an easily ignited surface (e.g. paper, textiles, etc.) or in a flammable environment.** There is a risk of fire due to the charger heating up during operation.
- ▶ **Take care if you touch the charger while it is charging. Wear protective gloves.** The charger can get very hot, especially when the ambient temperature is high.
- ▶ **The battery may give off fumes if it becomes damaged or is used incorrectly. Ensure the area is well ventilated and seek medical attention should you experience any adverse effects.** The fumes may irritate the respiratory system
- ▶ **Do not place the charger or the battery near flammable materials. Ensure the battery is completely dry and placed on a fireproof surface before charging.** There is a risk of fire due to the heat generated during charging.
- ▶ **The eBike battery must not be left unattended while charging.**
- ▶ **Supervise children during use, cleaning and maintenance.** This will ensure that children do not play with the charger.
- ▶ **Children or persons who, owing to their physical, sensory or mental limitations or to their lack of experience or knowledge, are not capable of safely operating the charger may only use this charger under supervision or after having been instructed by a responsible person.** Otherwise, there is a danger of operating errors and injuries.

- ▶ **Read and observe the safety warnings and directions contained in all the eBike system operating instructions and in the operating instructions of your eBike.**
- ▶ A sticker in English is adhered to the bottom of the charger (marked **(4)** in the diagram on the graphics page). This says: Use **ONLY** with BOSCH lithium-ion batteries.

Product description and specifications

In addition to the functions shown here, changes to software relating to troubleshooting and functional enhancements may be introduced at any time.

Product features

The numbering of the components shown refers to the illustrations on the graphics pages at the beginning of the manual.

Individual illustrations in these operating instructions may differ slightly from the actual conditions depending on the equipment of your eBike.

- (1) Charger
- (2) Device socket
- (3) Device connector
- (4) Charger safety instructions
- (5) Charging connector
- (6) Socket for charging connector
- (7) Charging socket cover
- (8) Rack-mounted battery
- (9) Operation/state of charge indicator
- (10) Battery on/off button
- (11) Standard battery

Technical data

Charger		Standard Charger (36–4/230)	Compact Charger (36–2/100-230)	Fast Charger (36–6/230)
Product code		BCS220	BCS230	BCS250
Rated voltage	V ~	207. 264	90. 264	207. 264
Frequency	Hz	47. 63	47. 63	47. 63
Battery charging voltage	V =	36	36	36
Charging current (max.)	A	4	2	6 ^{A)}
Charging time				
– PowerPack 300, approx.	hrs	2,5	5	2
– PowerPack 400, approx.	hrs	3,5	6,5	2,5
– PowerPack 500, approx.	hrs	4,5	7,5	3
Operating temperature	°C	0 . +40	0 . +40	0 . +40
Storage temperature	°C	–10 . +50	–10 . +50	–10 . +50
Weight, approx.	g	0,8	0,6	1,0
Protection rating		IP 40	IP 40	IP 40

A) The charging current is limited to 4A for the PowerPack 300 and for Classic + Line batteries.

The specifications apply to a rated voltage [U] of 230 V. These specifications may vary at different voltages and in country-specific models.

Operation

Start-up

Connecting the charger to the mains (see figure A)

- **Pay attention to the mains voltage.** The voltage of the power source must match the voltage specified on the rating plate of the charger. Chargers marked 230 V can also be operated at 220 V.

Plug the device connector **(3)** of the power cable into the device socket **(2)** on the charger.

Connect the power cable (country-specific) to the mains.

Charging the removed battery (see figure B)

Switch the battery off and remove it from its holder on the eBike. When doing so, read and observe the operating instructions of the battery

- **Ensure the battery is placed on clean surfaces only.** Avoid getting dirt, e.g. sand or soil, in the charging socket and contacts in particular.

Plug the charging connector **(5)** of the charger into the socket **(6)** on the battery

Charging the battery on the bike (see figures C and D)

Switch the battery off. Clean the cover of the charging socket **(7)**. Avoid getting dirt, e.g. sand or soil, in the charging socket and contacts in particular. Lift the cover of the charging socket **(7)** and plug the charging connector **(5)** into the charging socket **(6)**

- **Charge the battery only in accordance with all safety instructions.** If this is not possible, remove the battery from the holder and charge it in a more suitable location.

When doing so, read and observe the operating instructions of the battery

Charging process for two batteries

If two batteries are fitted to an eBike, both batteries can be charged using the uncovered connection. To begin with, both batteries are charged one after the other until they reach approx. 80–90 % capacity, then they are both charged at the same time until full (the LED flashes on both batteries).

When the bike is in operation, power is drawn from both batteries on an alternating basis.

If you take the batteries out of the holders, you can charge each one individually

Charging process

The charging process begins as soon as the charger is connected to the battery or charging socket on the bike and to the mains.

Note: The charging process is only possible when the temperature of the eBike battery is within the permitted charging temperature range.

Note: The drive unit is deactivated during the charging process.

The battery can be charged with or without the on-board computer. When charging without the on-board computer, the charging progress can be observed via the battery charge indicator.

When the on-board computer is connected, a charging notification appears on the display

The state of charge is displayed by the battery charge indicator (9) on the battery and by the bars on the on-board computer.

The LEDs on the battery charge indicator (9) will flash during the charging process. Each solid illuminated LED represents approximately 20 % of the charging capacity. The flashing LED indicates the next 20 % currently charging.

Once the eBike battery is fully charged, the LEDs extinguish immediately and the on-board computer is switched off. The charging process is terminated. The state of charge can be displayed for three seconds by pressing the on/off button (10) on the eBike battery



Disconnect the charger from the mains and the battery from the charger.

When the battery is disconnected from the charger, the battery is automatically switched off.

Note: If you have charged the battery on the bike, carefully close the charging socket (6) with the cover (7) after charging, so that no dirt or water can get in.

If the charger is not disconnected from the battery after charging, the charger will switch itself back on after a few hours, check the state of charge of the battery and begin the charging process again if necessary

Errors – causes and corrective measures

Cause	Corrective measures
 Battery defective	Two LEDs flash on the battery. Contact an authorised bike dealership.
 Battery too warm or too cold	Three LEDs flash on the battery. Disconnect the battery from the charger until the charging temperature range has been reached. Do not reconnect the battery to the charger until it has reached the correct charging temperature.
 The charger is not charging.	No LEDs flashing (one or more LEDs will remain permanently lit depending on the state of charge of the eBike battery). Contact an authorised bike dealership.

Charging not possible (no indicator on battery)

Connector not attached properly	Check all connections.
Battery contacts dirty	Carefully clean the battery contacts.

Cause	Corrective measures
socket outlet, cable or charger defective	Check the mains voltage, have the charger checked over by a bike dealership.
Battery defective	Contact an authorised bike dealership.

Maintenance and servicing

Maintenance and cleaning

If the charger fails, please contact an authorised bike dealership.

After-sales service and advice on using products

If you have any questions about the charger, contact an authorised bike dealership.

For contact details of authorised bike dealerships, please visit www.bosch-ebike.com

Disposal

Chargers, accessories and packaging should be recycled in an environmentally friendly manner.

Do not dispose of chargers along with household waste.

Only for EU countries:



According to the European Directive 2012/19/EU on Waste Electrical and Electronic Equipment and its implementation into national law, chargers that are no longer usable must be collected separately and disposed of in an environmentally friendly manner.

Subject to change without notice.

12 Keyword index

A

- Air chamber, 17
- Air valve
 - Fork, 16
 - Rear frame damper, 17
- Alternative, 6

B

- Back-pedal brake,
 - braking, 78
- Battery level indicator, 31
- Battery, 21
 - charging, 69
 - checking, 40
 - disposing of, 96
 - removing, 68, 70
 - waking, 71
- Belt tension, 90
- Brake arm, 17
- Brake calliper, 18
- Brake disc, 18
- Brake lever, 31
 - adjusting the pressure point 55
- Brake lining, 17, 18
 - maintaining, 89
- Brake,
 - using the transport securing system, 37
- Break in operation, 38
 - carrying out, 38
 - preparing, 38
- Button,
 - Minus, 23
 - On-Off (battery), 22
 - On-Off (display), 23
 - Plus, 23
 - Push assist, 23

C

- Chain drive, 20
- Chain guard,
 - checking, 65
- Chain tension, 90
- Chain wheel, 20
- Chain, 14, 20
 - maintaining, 90
- Charger,
 - disposing of, 96
- Clamping force,
 - Checking the quick releases, 42
 - Setting the quick releases, 42

D

- Direction of travel, 20
- Display,
 - charging the battery, 73, 74
- Down tube battery,
 - removing, 68, 70
- Drive system, 20
 - switching off, 72
 - switching on, 72

E

- EC declaration of conformity, 116

F

- Fork lock,
 - Position, 16

Fork, 15

- setting the compression damper, 81
- Fork end, 15
- Setting the rebound damper, 81
- structure, 16
- Frame, 14
- Front wheel brake, 17, 18
 - braking, 77
- Front wheel, see Wheel

G

- Gear recommendation, 32
- Gear shift twist grip, 31
 - checking, 90
- Gear shift,
 - maintaining, 90
 - switching, 81

H

- Handlebars, 14, 31
- Headlight, 20
- Hub, 15

I

- Initial commissioning 40

J

- Journey information, 31, 32
 - switching, 75
- Avg. speed, 32
- Clock, 32
- Max. speed, 32
- Odometer, 32
- Range, 32
- Trip distance, 32
- Trip Time, 32

L

- Level of assistance,
 - selecting, 75
- Lever, 17

M

- Minimum insertion depth marking, 53
- Minus button, 23
- Model year, 7
- Motor, 20
- Mudguards,
 - checking, 65

O

- On-Off button,
 - Battery, 22
 - Display, 23
- On-screen indicator, 31, 64
- Operating status indicator, 31
- O-ring, 17

P

- Packaging, 39
- Pannier rack,
 - changing, 66
 - checking, 65
 - using, 66
- Parts list, 116
- Pedal, 18, 20
- Plus button, 23
- Push assist button, 23
- Push assist,
 - using, 74

Q

- Quick release, 15
 - Position, 16

R

- Range, 31
- Rear frame damper,
 - structure, 17
- Rear light, 20
- Rear wheel brake, 18
- Rebound damper adjuster,
 - Position, 16
- Retainer guard, 22
- Riding light, 23
 - checking function, 65
- Rim brake locking lever 17
- Rim, 15
 - checking, 88
- Roller brake,
 - braking, 78

S

- Saddle, 14
 - changing the saddle tilt, 52
 - changing the seat length, 53
 - determining the saddle height, 52, 53
- Seat post, 14
- Securing hook, 22
- Setting wheel, 17
- Shifter,
 - checking, 90
 - setting, 92
- Spoke, 15
- Storage, 37
- Storing, see Storage
- Suspension head, 15
- System message, 32, 34, 49
- System setting, 32, 33
 - changeable, 32, 33, 34
 - System data, 32, 33

T

- Total journey duration, 33
- Total, 31
- Transportation, 36
- Transporting, see Transportation
- Trip, 31
- Type number, 7
- Tyres, 15
 - checking, 88

U

- USB port, 23
- Using 82

V

- Valve cap, 16
- Valve, 15
 - Dunlop valve, 15
 - Presta valve, 15
 - Schrader valve, 15

W

- Weight,
 - permitted total weight, 7
- Wheel,
 - maintaining, 88
- Winter break, see Break in operation

13 Glossary

Brake lever

Source: EN 15194:2017: lever used to apply the brake.

Braking distance

Source: EN 15194:2017: distance travelled by a pedelec between the commencement of braking and the point at which the pedelec comes to rest.

Cargo bike

Source: DIN 79010: bicycle mainly designed to carry goods.

CE marking

Source: Directive 2006/42/EC on Machinery: the manufacturer uses the CE marking to declare that the Pedelec complies with the applicable requirements.

City and trekking bicycles

Source: EN-ISO 4210 - 2: pedelec designed for use on public roads primarily for means of transportation or leisure.

Consumables

Source: EN 82079-1: any part or material that is necessary for continued use or maintenance of the product.

Decommissioning

Source: DIN 31051: intentional, unlimited interruption in an object's functional capability.

Disc brake

Source: EN 15194:2017: brake in which brake pads are used to grip the lateral faces of a thin disc attached to or incorporated in the wheel hub.

Drive belt

Source: EN 15194:2017: seamless ring belt which is used as a means of transmitting motive force.

Electrical control system

Source: EN 15194:2017: electronic and/or electrical component, or an assembly of components provided for installation into a vehicle, together with all electrical connections

and associated wiring for the motor electrical power assistance.

Electrically power assisted cycle, pedelec

Source: EN 15194:2017: electrically power assisted cycle, equipped with pedals and an auxiliary electric motor, which cannot be propelled exclusively by means of the auxiliary electric motor, except in start-up assistance mode.

Fault

Source: EN 13306:2018-02, 6.1: state of an item (4.2.1) characterized by inability to perform a required function (4.5.1), excluding the inability during preventive maintenance or other planned actions, or due to lack of external resources.

Folding bicycle

Source: EN-ISO 4210-2: bicycle designed to fold into a compact form, facilitating transport and storage.

Fork steerer

Source: EN 15194:2017: part of a fork that rotates about the steering axis of a bicycle frame head tube. It is normally connected to the fork crown or directly to the fork legs, and is normally the point of connection between the fork and the handlebar stem.

Fracture

Source: EN 15194:2017: unintentional separation into two or more parts.

Instruction handbook

Source: ISO/FDIS 20607:2018: part of the user information that machine manufacturers provide to machine operators; it contains guidance, instructions and tips related to the use of the machine in all its life cycle phases.

Maintenance

Source: DIN 31051: maintenance is generally performed at regular intervals and often carried out by trained technical staff. This ensures a maximum service life and low wear and tear for the maintained items. Proper maintenance is often also a pre-requisite for providing a warranty.

Maximum continuous power

Source: ZEG: the maximum continuous power is the maximum power for the electric motor output shaft during 30 minutes.

Maximum saddle height

Source: EN 15194:2017: vertical distance from the ground to the point where the top of the seat surface is intersected by the seat-post axis, measured with the saddle in a horizontal position and with the seat-post set to the minimum insertion-depth mark.

Maximum tyre pressure

Source: EN 15194:2017: maximum tyre pressure recommended by the tyre or rim manufacturer for a safe and efficient performance. If the rim and tyre both indicate a maximum tyre pressure, the maximum inflation pressure is the lower of the two pressures indicated.

Minimum insertion depth mark

Source: EN 15194:2017: mark indicating the minimum insertion-depth of handlebar stem into fork steerer (fork stem) or seat post into frame.

Model year

Source: ZEG: the model year refers to the first production year that the series-manufactured pedelec was manufactured in the version in question and is not always identical with the year of manufacture. The year of manufacture may be before the model year in some cases. If no technical modifications are introduced to the series, production may continue of pedelecs from a previous model year.

Mountain bike

Source: EN-ISO 4210-2: bicycle designed for use off-road on rough terrain, on public roads, and on public pathways, equipped with a suitably strengthened frame and other components, and, typically, with wide-section tyres with coarse tread patterns and a wide range of transmission gears.

Off-road rough terrain

Source: EN 15194:2017: coarse pebble tracks, forest trails, and other general off-road tracks where tree roots and rocks are likely to be encountered.

Permitted total weight

Source: EN 15194:2017: weight of the fully assembled pedelec plus the rider and baggage, as specified by the manufacturer.

Quick-release device, quick release

Source: EN 15194:2017: lever actuated mechanism that connects, retains or secures a wheel or any other component.

Racing bicycle

Source: EN-ISO 4210-2: bicycle intended for high-speed amateur use on public roads having a steering assembly with multiple grip positions allowing for an aerodynamic posture, a multi-speed transmission system, tyre width not greater than 28 mm and a maximum mass of 12 kg for the fully assembled bicycle.

Seat post

Source: EN 15194:2017: component that clamps the saddle (with a bolt or assembly) and connects it with the frame.

Shut-off speed

Source: EN 15194:2017: speed reached, by the pedelec, at the moment the current has dropped to zero or to the no load current value.

Spare part

Source: EN 13306:2018-02, 3.5: item intended to replace a corresponding item in order to retain or maintain the original required function of the item.

Suspension fork

Source: EN 15194:2017: front fork incorporating controlled, axial flexibility to reduce the transmission of road-shocks to the rider.

Suspension frame

Source: EN 15194:2017: frame incorporating controlled, vertical flexibility to reduce the transmission of road-shocks to the rider.

Type number

Source: ZEG: all pedelec models have an eight-digit type number which is used to specify the design model year, the type of pedelec and the version.

Wear

Source: DIN 31051: reduction in useful life (4.3.4), caused by chemical and/or physical processes.

Weight of ready-to-ride bicycle

Source: ZEG: the indicated weight for a ready-to-ride bicycle refers to the weight of a pedelec at the time of sale. The weight of each additional accessory must be added to this weight.

Wheel

Source: EN 15194:2017: assembly or combination of hub, spokes or disc, and rim, but excluding tyre assembly.

Work environment

Source: EN ISO 9000:2015: set of conditions under which work is performed

Year of manufacture

Source: ZEG: the year of manufacture is the year in which the Pedelec was manufactured. The production period is always from August to July of the following year

Young adult bicycle

Source: EN-ISO 4210-2: bicycle designed for use on public roads by a young adult whose weight is less than 40 kg, with maximum saddle height of 635 mm or more and less than 750 mm. (see ISO 4210).

I. EC declaration of conformity

Translation of the original EC declaration of conformity

The manufacturer:

HERCULES GMBH
 Longericher Straße 2
 50739 Köln, Germany

hereby declares that the electrically power assisted cycles of types:

20-Q-0022, 20-Q-0023, 20-Q-0024, 20-Q-0025, 20-Q-0026, 20-Q-0027, 20-Q-0061,
 20-Q-0062, 20-Q-0067, 20-Q-0070, 20-Q-0071, 20-Q-0075, 20-Q-0076, 20-Q-0077,
 20-Q-0078, 20-Q-0079, 20-Q-0083, 20-Q-0084, 20-Q-0085, 20-Q-0086, 20-Q-0087,
 20-Q-0088, 20-Q-0089, 20-Q-0091, 20-Q-0092, 20-Q-0093, 20-Q-TBD, 20-Y-0012,
 20-Y-0013

Year of manufacture 2019 and year of manufacture 2020

comply with all applicable requirements of *Machinery Directive 2006/42/EC*.

Furthermore, the electrically power assisted cycles comply with all applicable basic requirements of *Electromagnetic Compatibility Directive 2014/30/EU*.

The following standards were applied: *ISO/DIS 20607:2018* Safety of machinery –
 Instruction handbook – General drafting principle; *EN 15194:2017* Cycles –
 Electrically power assisted cycles – EPAC bicycles and *EN 11243:2016* Cycles –
Luggage carriers for bicycles – Requirements and test methods.

Ms. Janine Otto (Technical Editor), c/o HERCULES GMBH, Longericher Straße 2,
 50739 Köln, Germany, is authorised to compile the technical documentation.



Cologne, 27/05/2019

.....
 Place, date and signature

Georg Honkomp

-Managing Director-