

TRANSLATION OF THE ORIGINAL OPERATING INSTRUCTIONS

IMPORTANT

READ CAREFULLY BEFORE USE

KEEP SAFE TO CONSULT AT A LATER DATE



HERCULES

Panasonic

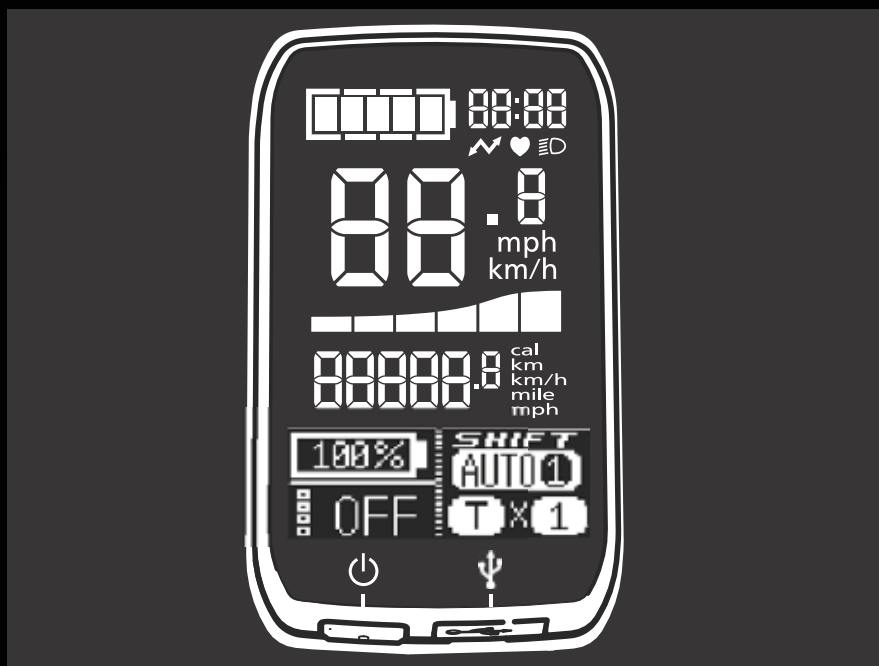

Panasonic Pedelecs

Intero I-R8 ZR 28" 8G, Intero I-8 ZR 28" 8G

20-Q-0055, 20-Q-0056

MY20H08-2 • 1.0 • 30. August 2019

Contents

| | | | | | |
|---------|--|----|---------|---|----|
| 1 | About these operating instructions | 5 | 3.2 | Proper use | 22 |
| 1.1 | Manufacturer | 5 | 3.3 | Improper use | 23 |
| 1.2 | Type number and model | 5 | 3.4 | Technical data | 24 |
| 1.3 | Identifying the operating instructions | 5 | 3.4.1 | Pedelec | 24 |
| 1.4 | Laws, standards and directives | 6 | 3.4.2 | Panasonic GX Power Motor | 24 |
| 1.5 | Subject to change | 6 | 3.4.3 | Panasonic TP-PCT rechargeable battery | 24 |
| 1.6 | Language | 6 | 3.4.4 | USB port | 24 |
| 1.7 | For your safety | 6 | 3.4.5 | Display | 24 |
| 1.7.1 | Instruction, training and customer service | 6 | 3.4.6 | Control device | 24 |
| 1.7.2 | Basic safety instructions | 6 | 3.4.7 | Emissions | 24 |
| 1.7.3 | Warnings | 6 | 3.4.8 | Tightening torque | 24 |
| 1.7.4 | Safety markings | 7 | 3.5 | Description of controls and screens | 25 |
| 1.8 | For your information | 7 | 3.5.1 | Handlebars | 25 |
| 1.8.1 | Information on the nameplate | 7 | 3.5.2 | Display | 25 |
| 1.9 | Nameplate | 8 | 3.5.2.1 | Current speed | 25 |
| 2 | Safety | 9 | 3.5.2.2 | Battery level indicator | 25 |
| 2.1 | General warnings | 9 | 3.5.2.3 | Level of assistance | 26 |
| 2.2 | Toxic substances | 10 | 3.5.2.4 | Function display | 26 |
| 2.3 | Requirements for the rider | 11 | 3.5.2.5 | Journey information | 26 |
| 2.4 | Vulnerable groups | 12 | 3.5.2.6 | System settings and data | 26 |
| 2.5 | Data privacy | 12 | 3.5.2.7 | System message | 26 |
| 2.6 | Personal protective equipment | 12 | 3.5.3 | Control panel | 26 |
| 2.7 | Safety markings and safety instructions | 12 | 3.6 | Environmental requirements | 27 |
| 2.8 | Emergency | 12 | 4 | Transporting and storing | 29 |
| 2.8.1 | What to do in an emergency | 12 | 4.1 | Physical transport characteristics | 29 |
| 2.8.2 | First aid treatment | 13 | 4.1.1 | Dimensions during transportation | 29 |
| 2.8.3 | Fighting fire | 13 | 4.1.2 | Transport weight | 29 |
| 2.8.4 | Leaking fluids | 13 | 4.1.3 | Designated handles/lifting points | 29 |
| 2.8.4.1 | Brake fluid | 13 | 4.2 | Transporting | 29 |
| 2.8.4.2 | Oils and lubricants from the fork | 13 | 4.2.1 | Transporting the battery | 30 |
| 2.8.4.3 | Oils and lubricants from the rear frame damper | 13 | 4.2.2 | Shipping the battery | 30 |
| 3 | Overview | 14 | 4.2.3 | Using the brake transport securing system | 30 |
| 3.1 | Description | 15 | 4.3 | Storing | 30 |
| 3.1.1 | Wheel and suspension | 15 | 4.3.1 | Break in operation | 31 |
| 3.1.1.1 | Valve | 15 | 4.3.1.1 | Preparing a break in operation | 31 |
| 3.1.2 | Suspension | 15 | 4.3.1.2 | Taking out of operation | 31 |
| 3.1.2.1 | Steel suspension fork structure | 16 | 5 | Assembly | 32 |
| 3.1.2.2 | Air suspension fork structure | 16 | 5.1 | Required tools | 32 |
| 3.1.2.3 | Structure of the FOX rear frame damper | 17 | 5.2 | Unpacking | 32 |
| 3.1.2.4 | Structure of the Suntour rear frame damper | 17 | 5.2.1 | Scope of delivery | 32 |
| 3.1.3 | Brake system | 17 | 5.3 | Commissioning | 33 |
| 3.1.3.1 | Rim brake | 17 | 5.3.1 | Checking the battery | 33 |
| 3.1.3.2 | Disc brake | 18 | 5.3.2 | Initial use of the display | 33 |
| 3.1.3.3 | Back-pedal brake | 18 | 5.3.3 | Installing the wheel in the Suntour fork | 34 |
| 3.1.4 | Electric drive system | 19 | 5.3.3.1 | Installing the wheel with screw-on axle (15 mm) | 34 |
| 3.1.5 | Rechargeable battery | 20 | 5.3.3.2 | Installing the wheel with screw-on axle (20 mm) | 35 |
| 3.1.6 | Riding light | 20 | 5.3.3.3 | Installing the wheel with a quick release axle | 35 |
| 3.1.7 | Control panel | 20 | | | |
| 3.1.8 | Display | 21 | | | |

| | | | | | |
|---------|---|----|----------|---|----|
| 5.3.4 | Installing the wheel with a quick release | 37 | 6.4.8 | Retracting the brake linings | 53 |
| 5.3.5 | Installing the wheel in the FOX fork | 38 | 6.5 | Accessories | 54 |
| 5.3.5.1 | Wheel with quick release (15 mm) | 38 | 6.5.1 | Child seat | 54 |
| 5.3.5.2 | Adjusting the FOX quick release | 38 | 6.5.2 | Bicycle trailers | 55 |
| 5.3.5.3 | Installing the wheel with Kabolt axles | 39 | 6.5.3 | Pannier rack | 55 |
| 5.3.5.4 | Checking the stem and handlebars | 39 | 6.6 | Before each ride | 56 |
| 5.3.6 | Pedelec sale | 39 | 6.7 | Check list before each ride | 56 |
| 6 | Operation | 40 | 6.8 | Using the kickstand | 57 |
| 6.1 | Risks and hazards | 40 | 6.8.1 | Raising the kickstand | 57 |
| 6.1.1 | Tips for a greater range | 41 | 6.8.1.1 | Parking the pedelec | 57 |
| 6.1.2 | Personal protective equipment | 41 | 6.9 | Using the pannier rack | 57 |
| 6.2 | Error messages | 42 | 6.10 | Rechargeable battery | 58 |
| 6.2.1 | Error message display | 42 | 6.10.1 | Removing the battery | 59 |
| 6.3 | Instruction and customer service | 43 | 6.10.2 | Inserting the battery | 59 |
| 6.4 | Adjusting the pedelec | 43 | 6.10.3 | Charging the battery | 59 |
| 6.4.1 | Adjusting the saddle | 43 | 6.10.4 | Waking the battery | 60 |
| 6.4.1.1 | Adjusting the saddle tilt | 43 | 6.11 | Electric drive system | 61 |
| 6.4.1.2 | Determining the seat height | 43 | 6.11.1 | Switching on the electric drive system | 61 |
| 6.4.1.3 | Adjusting the seat height with quick release | 44 | 6.11.2 | Switching off the drive system | 61 |
| 6.4.1.4 | Height-adjustable seat post | 44 | 6.12 | Display | 62 |
| 6.4.1.5 | Adjusting the seat position | 45 | 6.12.1 | Removing and attaching the display | 62 |
| 6.4.2 | Adjusting the handlebars | 45 | 6.12.1.1 | Attaching the display | 62 |
| 6.4.2.1 | Adjusting the stem | 45 | 6.12.2 | Securing the display against removal | 62 |
| 6.4.2.2 | Adjusting the height of the handlebars | 45 | 6.12.2.1 | Removing the display | 63 |
| 6.4.2.3 | Adjusting the quick release clamping force | 46 | 6.12.3 | Using the USB port | 63 |
| 6.4.3 | Adjusting the brake lever | 46 | 6.12.4 | Using the push assist system | 64 |
| 6.4.3.1 | Adjusting the pressure point on a Magura brake lever | 46 | 6.12.5 | Using the riding light | 64 |
| 6.4.3.2 | Adjusting the grip distance | 46 | 6.12.6 | Using night mode | 64 |
| 6.4.3.3 | Adjusting the grip distance on a Magura brake lever | 47 | 6.12.7 | Selecting the level of assistance | 64 |
| 6.4.4 | Adjusting Suntour fork | 47 | 6.12.8 | Journey information | 65 |
| 6.4.4.1 | Adjusting the negative deflection | 47 | 6.12.8.1 | Changing the displayed journey information | 65 |
| 6.4.4.2 | Adjusting the steel suspension fork negative deflection | 48 | 6.12.8.2 | Resetting the journey information | 65 |
| 6.4.4.3 | Adjusting the air suspension fork negative deflection | 48 | 6.12.9 | Changing the system settings | 65 |
| 6.4.4.4 | Adjusting the air suspension fork rebound | 49 | 6.12.9.1 | Changing the language | 65 |
| 6.4.5 | Adjusting the FOX fork | 49 | 6.12.9.2 | Changing the display contrast | 65 |
| 6.4.5.1 | Adjusting the negative deflection | 49 | 6.12.9.3 | Changing the brightness | 66 |
| 6.4.5.2 | Adjusting the rebound | 50 | 6.12.9.4 | Changing the unit of measure for speed | 66 |
| 6.4.6 | Setting the Suntour rear frame damper | 51 | 6.12.9.5 | Setting information on the tyre size | 66 |
| 6.4.6.1 | Adjusting the negative deflection | 51 | 6.12.9.6 | Changing the distance travelled | 66 |
| 6.4.6.2 | Adjusting the rebound | 51 | 6.12.9.7 | Setting the clock | 67 |
| 6.4.6.3 | Setting the compression | 51 | 6.12.10 | Replacing the battery | 67 |
| 6.4.7 | Setting the FOX rear frame damper | 52 | 6.13 | Brake | 68 |
| 6.4.7.1 | Adjusting the negative deflection | 52 | 6.13.1 | Using the brake lever | 69 |
| 6.4.7.2 | Adjusting the rebound | 52 | 6.13.2 | Using the back-pedal brake | 70 |
| | | | 6.14 | Suspension and damping | 70 |
| | | | 6.14.1 | Adjusting the compression of the Fox fork | 70 |
| | | | 6.14.2 | Adjusting the compression of the Fox damper | 70 |
| | | | 6.14.3 | Adjusting the compression of the Suntour fork | 71 |

| | | | | | |
|---------|---|----|-------|---|-----|
| 6.14.4 | Adjusting the compression of a Suntour damper | 71 | 8 | Maintenance | 81 |
| 6.14.5 | Adjusting the rebound in a Rock Shox damper | 71 | 8.1 | Axle with quick release | 82 |
| 6.14.6 | Adjusting the compression in a Rock Shox damper | 72 | 8.1.1 | Checking the quick release | 82 |
| 6.15 | Gear shift | 72 | 8.2 | Adjusting the gear shift | 82 |
| 6.15.1 | Selecting gears | 72 | 8.2.1 | Cable-operated gear shift, single-cable | 83 |
| 6.15.2 | Using the hub gear | 73 | 8.2.2 | Cable-operated gear shift, dual-cable | 83 |
| 7 | Cleaning and servicing | 74 | 8.2.3 | Cable-operated twist grip, dual-cable | 83 |
| 7.1 | Cleaning after each ride | 74 | 9 | Troubleshooting, fault clearance and repair | 84 |
| 7.1.1 | Cleaning the suspension fork | 74 | 9.1 | Troubleshooting and fault clearance | 84 |
| 7.1.2 | Cleaning the rear frame damper | 74 | 9.1.1 | The drive system or display do not start up | 84 |
| 7.1.3 | Cleaning the pedals | 74 | 9.1.2 | Error messages | 84 |
| 7.2 | Basic cleaning | 75 | 9.2 | Switching on | 85 |
| 7.2.1 | Cleaning the frame | 75 | 9.3 | Assistance function | 85 |
| 7.2.2 | Cleaning the stem | 75 | 9.4 | Rechargeable battery | 86 |
| 7.2.3 | Cleaning the wheel | 75 | 9.5 | Lighting | 87 |
| 7.2.4 | Cleaning the drive elements | 75 | 9.6 | Display | 88 |
| 7.2.5 | Cleaning the rear frame damper | 76 | 9.7 | Miscellaneous | 88 |
| 7.2.6 | Cleaning the chain | 76 | 9.8 | Repair | 89 |
| 7.2.7 | Cleaning the battery | 76 | 9.8.1 | Use original parts and lubricants only | 89 |
| 7.2.8 | Cleaning the display | 76 | 9.8.2 | Replacing the lighting | 89 |
| 7.2.9 | Cleaning the drive unit | 76 | 9.8.3 | Adjusting the headlight | 89 |
| 7.2.10 | Cleaning the brake | 77 | 10 | Recycling and disposal | 90 |
| 7.3 | Servicing | 77 | 11 | Documents | 91 |
| 7.3.1 | Servicing the frame | 77 | 11.1 | Parts list | 91 |
| 7.3.2 | Servicing the stem | 77 | 11.2 | Assembly report | 92 |
| 7.3.3 | Servicing the fork | 77 | 11.3 | Maintenance log | 94 |
| 7.3.4 | Servicing the drive elements | 77 | 12 | Keyword index | 97 |
| 7.3.5 | Servicing the pedals | 77 | 13 | Glossary | 98 |
| 7.3.6 | Servicing the chain | 77 | 13.1 | Abbreviations | 100 |
| 7.3.7 | Servicing the drive elements | 77 | 13.2 | Simplified terms | 100 |
| 7.4 | Maintenance | 77 | I. | EC declaration of conformity | 101 |
| 7.4.1 | Wheel | 77 | | | |
| 7.4.1.1 | Checking the tyres | 78 | | | |
| 7.4.1.2 | Checking the rims | 78 | | | |
| 7.4.1.3 | Checking and adjusting the tyre pressure – Dunlop valve | 78 | | | |
| 7.4.1.4 | Checking and adjusting the tyre pressure – presta valve | 78 | | | |
| 7.4.1.5 | Checking and adjusting the tyre pressure – Schrader valve | 79 | | | |
| 7.4.2 | Brake system | 79 | | | |
| 7.4.3 | Checking the brake linings for wear | 79 | | | |
| 7.4.4 | Checking the pressure point | 79 | | | |
| 7.4.5 | Checking the brake discs for wear | 79 | | | |
| 7.4.6 | Electrical cables and brake cables | 79 | | | |
| 7.4.7 | Gear shift | 79 | | | |
| 7.4.8 | Stem | 80 | | | |
| 7.4.9 | USB port | 80 | | | |
| 7.4.10 | Checking the belt and chain tension | 80 | | | |

1 About these operating instructions

Thank you for your trust!

HERCULES pedelecs are premium quality bicycles. You have made an excellent choice. Your specialist dealer will provide you with guidance and assemble your product. Your specialist dealer will also be happy to assist you in the future whether you require maintenance, conversion or repair.

Notice

The *operating instructions* are not a substitute for personal instruction by the supplying specialist dealer.

The *operating instructions* are an integral part of the pedelec. Therefore, if it is re-sold at a later time, they must be handed over to the subsequent owner.

You receive these *operating instructions* with your new pedelec. Please take time to become familiar with your new pedelec and follow the tips and suggestions in the *operating instructions*. They will help you to enjoy your HERCULES pedelec for a long time to come. We hope you have fun and wish you well on all of your rides!

These operating instructions are designed for the rider and the operator to ensure that non-professionals can use the pedelec safely.



Instructions for the specialist dealer are highlighted in grey and marked with a symbol. Specialist dealers have specialist training and qualifications and are thus able to identify risks and prevent hazards which may arise during maintenance, servicing and repairs. Information for specialist staff does not require non-professionals to take any action.



Download the operating instructions onto your phone at the following link, so that you can use them when you are out riding:

<https://www.hercules-bikes.de/de/de/index/downloads.html>

1.1 Manufacturer

The pedelec manufacturer is:

HERCULES GMBH
Longericher Straße 2
50739 Köln, Germany

Tel.: +49 4471 18735 0
Fax: +49 4471 18735 29
E-mail: info@hercules-bikes.de
Internet: www.hercules-bikes.de

1.2 Type number and model

The *operating instructions* are an integral part of pedelecs with the following type numbers:

| Type no. | Model | Pedelec type |
|-----------|-----------------------------|---------------------------|
| 20-Q-0055 | Intero I-R8 ZR 28" 600Wh 8G | City and trekking bicycle |
| 20-Q-0055 | Intero I-R8 ZR 28" 500Wh 8G | City and trekking bicycle |
| 20-Q-0055 | Intero I-R8 ZR 28" 400Wh 8G | City and trekking bicycle |
| 20-Q-0056 | Intero I-8 ZR 28" 600Wh 8G | City and trekking bicycle |
| 20-Q-0056 | Intero I-8 ZR 28" 600Wh 8G | City and trekking bicycle |
| 20-Q-0056 | Intero I-8 ZR 28" 600Wh 8G | City and trekking bicycle |

Table 1: Type number, model and pedelec type

1.3 Identifying the operating instructions

You will find the *operating instructions* identification number at the bottom left-hand side of each page. The identification number consists of the document number, the version number and the release date.

| | |
|-----------------------|----------------------------|
| Identification number | MY20H08 - 1_1.0_30.08.2019 |
|-----------------------|----------------------------|

Table 2: Identification number

1.4 Laws, standards and directives

The *operating instructions* comply with the essential requirements specified in:

- Machinery Directive 2006/42/EC
- Electromagnetic Compatibility Directive 2014/30/EU
- ISO 20607:2018 Safety of machinery – Instruction handbook – General drafting principles
- EN 15194:2018 Cycles – Electrically power assisted cycles – pedelec bicycles
- EN 11243:2016, Cycles – Luggage carriers for bicycles – Requirements and test methods
- ISO 17100:2016-05 Translation Services – Requirements for translation services.

1.5 Subject to change

The information contained in these *operating instructions* are the approved technical specifications at the time of printing. Any significant changes will be included in a new issue of the *operating instructions*.

You will find any modifications to these *operating instructions*:

<https://www.hercules-bikes.de/de/de/index/downloads>.

1.6 Language

The *original operating instructions* are written in German. A translation is not valid without the *original operating instructions*.

1.7 For your safety

The pedelec's safety concept comprises four elements:

- rider and/or operator instruction, and maintenance and repair by the specialist dealer
- the section on general safety
- the warnings in these *operating instructions*
- the safety marking on the nameplate.

1.7.1 Instruction, training and customer service

The supplying specialist dealer will provide customer service. Contact details can be found on the pedelec pass for these operating instructions. If you are unable to contact your specialist dealer, you will find other specialist dealers online at www.hercules-bikes.de.

The rider or owner will be instructed in person on the pedelec's functions. Instruction will be given when the supplying specialist dealer hands over the pedelec at the latest.

Each rider who receives this bicycle must receive instruction on all pedelec functions. A copy of these operating instructions must be provided to each rider.

1.7.2 Basic safety instructions

These *operating instructions* explain all general safety instructions in Section 2 on Safety.

1.7.3 Warnings

Hazardous situations and actions are marked with warnings. The warnings in these *operating instructions* are indicated as follows:

 **DANGER**

Will lead to serious or even fatal injuries if ignored. High-risk hazard.

 **WARNING**

May lead to serious or even fatal injuries if ignored. Medium-risk hazard.

 **CAUTION**

May lead to minor or moderate injuries. Low-risk hazard.

Notice

May lead to material damage if ignored.

1.7.4 Safety markings

The following safety markings are used on the pedelec's nameplates:



| | |
|---|------------------------------------|
|  | General warning |
|  | Adhere to the instructions for use |

Table 3: Meaning of safety markings

1.8 For your information

Instructions for actions are structured in accordance with the following pattern:

- ✓ Requirements (optional)
- ▶ Instruction for action (individual)
- 1 Instruction for action (in specified order)
- ⇒ Result of the action (optional)

The pedelec described in these *operating instructions* may be equipped with alternative equipment. The pedelec equipment is defined by its respective type number. Where applicable, the word *Alternative* beneath the heading indicates alternatively used components. The following terms are used for better legibility:

| Term | Meaning |
|-------------------------------|---------------------------------|
| <i>Operating instructions</i> | Original operating instructions |
| Motor | Drive motor, sub-system |

The following conventions are used in these *operating instructions*:

| Convention | Use |
|-------------------|--|
| <i>Italics</i> | Glossary term |
| <u>underlined</u> | Links and cross references in the document |
| SPACED | Indicators on the <i>display screen</i> |
| • | Bulleted lists |

1.8.1 Information on the nameplate

Besides warnings, product nameplates also contain other important information about the pedelec:









| | | |
|---|--|---|
|  |  | Read the instructions |
|  | | Separate collection of electrical and electronic devices |
|  | | Separate collection of batteries |
|  | | Must not be thrown into fire (burning prohibited) |
|  | | Battery must not be opened |
|  | | Device of protection class II |
|  | | Only suitable for use indoors |
|  | | Fuse (device fuse) |
|  | | EU conformity |
|  | | Recyclable material |
|  | | Protect from temperatures above 50 °C and direct sunlight |

Table 4: Relevance of safety instructions

1.9 Nameplate

The nameplate is situated on the frame. You will find the precise position of the nameplate in Figure 2. You will find thirteen pieces of information on the nameplate.

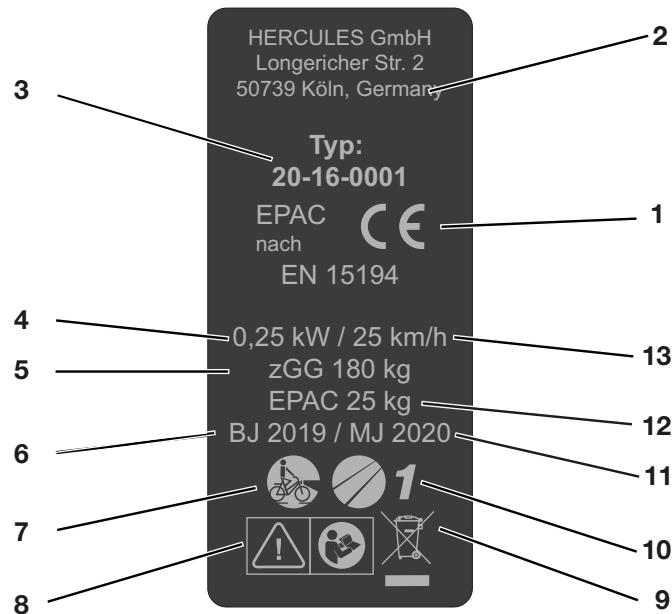

Figure 1: Nameplate, example

| No. | Designation | Description |
|-----|-------------------------------------|--|
| 1 | CE marking | The manufacturer uses the CE marking to declare that the pedelec complies with applicable requirements. |
| 2 | Manufacturer's contact details | You can contact the manufacturer at this address. You can find more information in Section 1.1. |
| 3 | Type number | All pedelec models have an eight-digit type number, which is used to specify the design model year, the type of pedelec and the version. You can find further information in Section 1.9.1. |
| 4 | Maximum continuous power | The maximum continuous power is the maximum power for the electric motor output shaft during 30 minutes. |
| 5 | Permitted total weight | The permitted total weight is the weight of the fully assembled pedelec with the rider and baggage. |
| 6 | <i>Year of manufacture</i> | The <i>year of manufacture</i> is the year in which the pedelec was manufactured. The production period is from August 2019 to July 2020. |
| 7 | Pedelec type | You can find further information in Section 1.9.3. |
| 8 | Safety markings | You can find more information in Section 2.6. |
| 9 | Disposal instructions | You can find more information in Section 10. |
| 10 | Area of use | You can find further information in Section 1.9.4. |
| 11 | Model year | The model year refers to the first production year that the series-manufactured pedelec was produced in the version and is not always identical with the <i>year of manufacture</i> . The <i>year of manufacture</i> may be before the model year in some cases. If no technical modifications are introduced to the series, production may continue of pedelecs from a previous model year. |
| 12 | Weight of the ready-to-ride pedelec | The indicated weight for a ready-to-ride pedelec refers to the weight at the time of purchase. The weight of each additional accessory must be added to this weight |
| 13 | <i>Shut-off speed</i> | Speed reached by the pedelec at the moment when the current has dropped to zero or to the no load current value. |

2 Safety

2.1 General warnings

WARNING

Risk of fire and explosion due to faulty battery

The safety electronics may fail if the battery is damaged or faulty. The residual voltage can cause a short circuit. The battery may self-ignite and explode.

- ▶ If the battery becomes deformed or begins to smoke, keep at a safe distance and disconnect the power supply at the socket. Contact the fire service immediately.
- ▶ Never extinguish a damaged battery with water or allow it to come into contact with water.
- ▶ If the battery is dropped or struck but shows no signs of external damage, remove it from service and observe it for at least 24 hours.
- ▶ Batteries with external damage must be removed from service immediately.
- ▶ Faulty batteries are hazardous goods. Dispose of faulty batteries properly and as quickly as possible.
- ▶ Store battery in a dry place until disposal. Never store in the vicinity of flammable substances.
- ▶ Never open or repair the battery.
- ▶ Only use and charge the battery and accessories if they are in perfect condition.

CAUTION

Electric shock in case of damage

Damaged chargers, cables and plug connectors increase the risk of electric shock.

- ▶ Check the charger, cable and plug connector before each use. Never use a damaged charger.

CAUTION

Risk of fire and explosion due to short circuit

Small metal objects may jumper the electrical connections of the battery. The battery may self-ignite and explode.

- ▶ Keep paper clips, screws, coins, keys and other small parts away and do not insert them into the battery.

Risk of fire and explosion due to incorrect charger

Batteries which are recharged with an unsuitable charger may become damaged internally. This may result in fire or an explosion.

- ▶ Only use batteries approved for the pedelec.
- ▶ Mark the supplied charger clearly to prevent mix-ups – with the *frame number* or *type number*, for example.

Risk of fire and explosion due to penetration by water

The battery is only protected from spray water. Penetration by water can cause a short circuit. The battery may self-ignite and explode.

- ▶ Never immerse the battery in water.
- ▶ If there is reason to believe that water may have entered into the battery, the battery must be removed from service.

Risk of fire and explosion due to high temperatures

Temperatures over 60 °C can also cause liquid to leak from the battery and the battery will become damaged. The battery may self-ignite and explode.

- ▶ Protect the battery against heat.
- ▶ Never store next to hot objects.
- ▶ Never expose the battery to sustained direct sunlight.
- ▶ Avoid wide temperature fluctuations.

 **CAUTION**
Fire caused by overheated charger

The charger heats up when charging the battery. In case of insufficient cooling, this can result in fire or burns to the hands.

- ▶ Never use the charger on a highly flammable surface (e.g. paper, carpet etc.).
- ▶ Never cover the charger during the charging process.

Never leave the battery unattended during charging.

Electric shock caused by penetration by water

If water penetrates into the charger, there is a risk of electric shock.

- ▶ Never charge the battery outdoors.

Notice

If you leave a key inserted when riding or transporting the pedelec, it may break off or the locking system may open accidentally.

- ▶ Remove the key from the battery lock immediately after use.
- ▶ We recommend that you attach the key to a key ring.

2.2 Toxic substances
 **DANGER**
Hydraulic fluid can be fatal if it is swallowed and penetrates into the respiratory system

Hydraulic fluid may leak out after an accident or due to material fatigue. Hydraulic fluid can be fatal if swallowed and inhaled.

First aid treatment

Wear gloves and safety goggles as protective equipment. Keep unprotected persons away.

- ▶ Remove those affected from the danger area to fresh air. Never leave those affected unattended.
- ▶ Ensure sufficient ventilation.
- ▶ Immediately remove clothing items contaminated with hydraulic fluid.
- ▶ Serious slip hazard due to hydraulic fluid leakage.
- ▶ Keep away from naked flames, hot surfaces and sources of ignition.
- ▶ Avoid contact with skin and eyes.
- ▶ Do not inhale vapours or aerosols.

After inhalation

- ▶ Take in fresh air. Immediately consult a doctor in case of any discomfort.

After skin contact

- ▶ Wash affected skin with soap and water and rinse well. Remove contaminated clothing. Consult doctor in the event of pain or discomfort.

After contact with eyes

- ▶ Rinse eyes under flowing water for at least ten minutes with the lids open; also rinse under lids. Immediately consult a doctor in case of any pain or discomfort.

After swallowing

- ▶ Rinse out mouth with water. Never induce vomiting! Risk of aspiration!
- ▶ Place a person lying on their back who is vomiting in a stable recovery position on their side. Seek medical advice immediately.

Environmental protection measures

- ▶ Never allow hydraulic fluid to flow into the sewage system, surface water or groundwater.
- ▶ Notify the relevant authorities if fluid penetrates the ground or pollutes water bodies or the sewage system.

 **WARNING**
Intoxication from suspension oil

Suspension oil in the rear frame damper is toxic to the touch, irritates respiratory tracts and causes cancer, sterility and mutation in germ cells.

- ▶ Never disassemble the rear frame damper.
- ▶ Never allow suspension oil to come into contact with the skin.

 **CAUTION**
Chemical burns to the skin and eyes caused by faulty battery

Liquids and vapours may leak from damaged or faulty batteries. Excessive temperatures can also cause liquid to leak from the battery and the battery will become damaged. They can irritate the airways and cause burns.

- ▶ Avoid contact with leaked liquids.
- ▶ Take in fresh air. Consult doctor in the event of pain or discomfort.
- ▶ Immediately consult a doctor in case of contact with the eyes or any discomfort.
- ▶ In case of contact with the skin, rinse off immediately with water.
- ▶ Ventilate the room well.

Environmental hazard posed by oil and lubricants from rear frame damper

The rear frame damper contains toxic and environmentally harmful oils and lubricants. Such fluids will contaminate if they enter the sewers or groundwater.

- ▶ Dispose of oils and lubricants which have leaked from the rear frame damper in an environmentally responsible way in accordance with statutory regulations. Contact your specialist dealer.

 **CAUTION**
Hazard for the environment due to leaking brake fluid

The brake system contains a toxic, environmentally harmful brake fluid. Such fluids will contaminate if they enter the sewers or groundwater.

- ▶ The brake system must be repaired immediately if brake fluid leaks out. Contact your specialist dealer.
- ▶ Dispose of leaking brake fluid in an environmentally responsible way in accordance with statutory regulations. Contact your specialist dealer.

Environmental hazard posed by oil and lubricants from the fork

The fork contains toxic, environmentally harmful oils and lubricants. Such fluids will contaminate if they enter the sewers or groundwater.

- ▶ The fork must be repaired immediately if oils and lubricants are leaking out. Contact your specialist dealer.
- ▶ Dispose of leaked oils and lubricants in an environmentally responsible way in accordance with statutory regulations. Contact your specialist dealer.

2.3 Requirements for the rider

If there are no legal requirements for riders of electrically power-assisted cycles, we recommend that the rider should be a minimum 15 years of age and have experience with muscle-powered bicycles.

The rider's physical and mental abilities must be adequate to use a muscle-powered pedelec.

2.4 Vulnerable groups

You must keep batteries and charger away from children and people with reduced physical, sensory or mental capabilities or lacking in experience and knowledge.

If minors use the pedelec, comprehensive instruction should be provided by or in the presence of the legal guardians. Supervised use should also be scheduled until the pedelec is being used as per these *operating instructions*.

2.5 Data privacy

During maintenance, the pedelec is connected to the diagnosis tool and data is transferred to Bosch Pedelec Systems (Robert Bosch GmbH) regarding the use of electric drive components to help improve the product. You will find more information on the Bosch Pedelec website <https://www.bosch-ebike.com/en/>.

2.6 Personal protective equipment

We recommend that you wear a suitable cycling helmet. We also recommend that you wear sturdy footwear and typical, close-fitting clothing for bicycles.

2.7 Safety markings and safety instructions

The nameplate contains the following safety markings and safety instructions:









| Symbol | Explanation |
|---|------------------------------------|
|  | General warning |
|  | Adhere to the instructions for use |

Table 5: Meaning of safety markings

| Symbol | Explanation |
|---|--|
|  | Read the instructions |
|  | Separate collection of electrical and electronic devices |
|  | Separate collection of ordinary and rechargeable batteries |
|  | Must not be thrown into fire (burning prohibited) |
|  | It is forbidden to open any batteries |
|  | Device of protection class II |
|  | Only suitable for use indoors |
|  | Fuse (device fuse) |
|  | EU conformity |
|  | Recyclable material |
|  | Protect from temperatures above 50 °C and direct sunlight |

2.8 Emergency

2.8.1 What to do in an emergency

- ▶ In the event of a hazard or danger in road traffic, apply the brakes on the pedelec until it comes to a halt. The brake acts as an emergency stop system in such cases.

2.8.2 First aid treatment

- ▶ Consult a doctor immediately in the event of any pain or discomfort caused by combustion gas or leaking fluids.

After inhalation

Vapours may emit if the battery is damaged or used improperly. The vapours may cause respiratory tract irritation.

- ▶ Get into fresh air.
- ▶ Consult doctor in the event of pain or discomfort.

After contact with eyes

- ▶ Rinse eyes with plenty of water for at least 15 minutes. Protect unaffected eye. Seek medical advice immediately.

After skin contact

- ▶ Remove any solid particles immediately.
- ▶ Rinse the affected area with plenty of water for at least 15 minutes. Then dab the affected skin gently. Do not rub dry.
- ▶ Remove contaminated clothing immediately.
- ▶ Immediately consult a doctor if there is any redness, pain or discomfort.

After swallowing

- ▶ Drink plenty of milk or water and induce vomiting.
- ▶ Seek medical advice immediately.

2.8.3 Fighting fire

WARNING



Intoxication

Inhaling vapours can cause intoxication.

- ▶ Stand on the side of the fire where the wind is blowing from.
- ▶ Use breathing apparatus if possible.

The safety electronics may fail if the battery is damaged or faulty. The residual voltage can cause a short circuit. The battery may self-ignite and explode.

- ▶ Keep your distance if the battery becomes deformed or starts to emit smoke.
- ▶ Evacuate everyone from the immediate area of the fire.
- ▶ Contact the fire service immediately!
- ▶ Use Class fire extinguishers to put out the fire.
- ▶ Never extinguish damaged batteries with water or allow them to come into contact with water.

2.8.4 Leaking fluids

2.8.4.1 Brake fluid

- ▶ The brake system must be repaired immediately if brake fluid leaks out. Contact your specialist dealer.
- ▶ Dispose of leaking brake fluid in an environmentally responsible way in accordance with statutory regulations. Contact your specialist dealer.

2.8.4.2 Oils and lubricants from the fork

- ▶ The brake system must be repaired immediately if brake fluid leaks out. Contact your specialist dealer.
- ▶ Dispose of leaking brake fluid in an environmentally responsible way in accordance with statutory regulations. Contact your specialist dealer.

2.8.4.3 Oils and lubricants from the rear frame damper

- ▶ Dispose of oils and lubricants which have leaked from the rear frame damper in an environmentally responsible way in accordance with statutory regulations. Contact your specialist dealer.

3 Overview



Figure 2: Pedelec viewed from the right, Futura Sport I F8 used as example

| | | | |
|---|--------------------|----|------------------------------|
| 1 | <i>Front wheel</i> | 10 | Pannier rack |
| 2 | <i>Fork</i> | 11 | Rear light and reflector |
| 3 | Front guard | 12 | Rear guard |
| 4 | Headlight | 13 | Rear wheel |
| 5 | <i>Handlebars</i> | 14 | Chain |
| 6 | <i>Stem</i> | 15 | Chain guard |
| 7 | Frame | 16 | Frame number |
| 8 | Seat post | 17 | <i>Battery and nameplate</i> |
| 9 | Saddle | | |

3.1 Description

3.1.1 Wheel and suspension

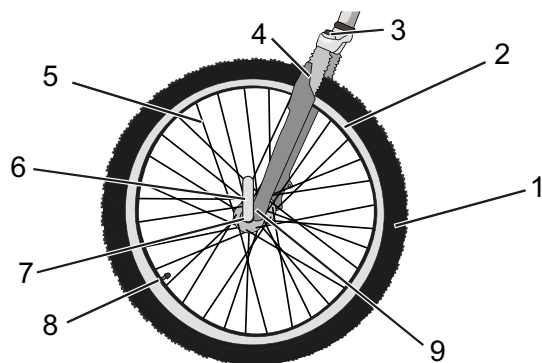

Figure 3: Components of the wheel, example of front wheel

- | | |
|---|---|
| 1 | Tyre |
| 2 | Rim |
| 3 | Suspension fork head with setting wheel |
| 4 | Shock absorber |
| 5 | Spoke |
| 6 | Quick release |
| 7 | Hub |
| 8 | Valve |
| 9 | Fork end of the shock absorber |

3.1.1.1 Valve

Each wheel has a valve. It is used to fill the *tyre* with air. There is a valve cap on each valve. The screw-on valve cap keeps out dust and dirt.

The pedelec either has a conventional *Dunlop valve*, a *Presta valve* or a *Schrader valve*.

3.1.2 Suspension

Both forks and suspension forks are fitted in this model series. A suspension fork is based either on a steel spring or air suspension. Unlike a rigid fork, a suspension fork has two functions which improve floor contact and comfort: suspension and damping.

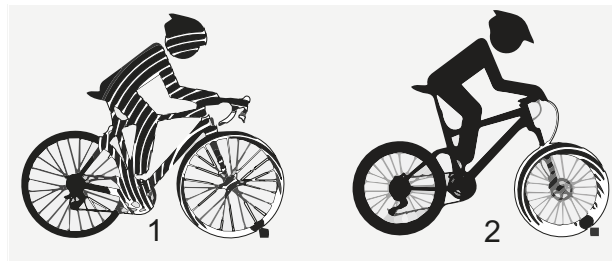

Figure 4: Pedelec without suspension (1) and with suspension (2) when riding over an obstacle

The suspension prevents an impact, such as one caused by a stone lying in the bike's path, from being channelled directly into the rider's body via the fork. The impact is absorbed by the suspension system instead. This causes the suspension fork to compress. The compression can be disabled so that a suspension fork reacts like a rigid fork. The switch to disable the fork is called a remote lockout.

After compressing, the suspension fork returns to its original position. If there is a damper, it decelerates movement, preventing the suspension system from springing back in an uncontrolled manner and stopping the fork from vibrating up and down. Dampers which dampen compressive deflection movements, i.e. a compression load, are called compression dampers or compression dashpots.

Dampers which dampen rebound deflection movements, i.e. a rebound load, are called rebound dampers or dashpots.

3.1.2.1 Steel suspension fork structure

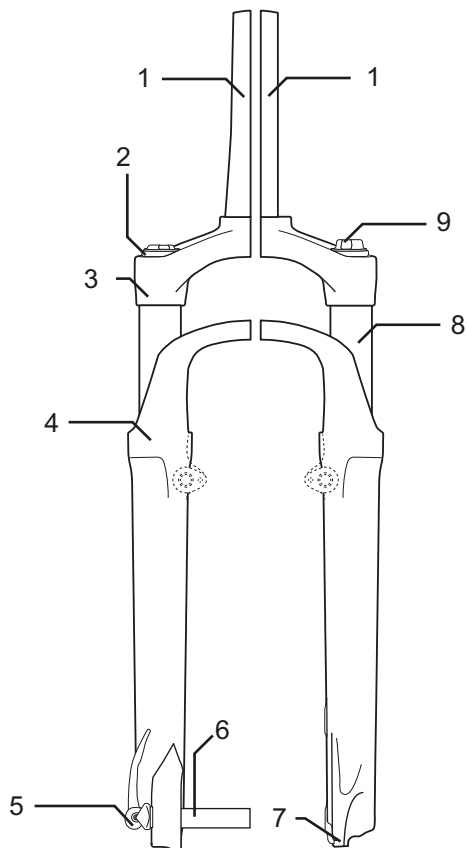

Figure 5: Example showing Suntour fork

The stem and handlebars are fastened to the fork steerer (1). The wheel is fastened to the quick release axle (6). Other elements: the compression setting (2), crown (3), Q-Loc (5), dust seal (6), fork end for quick release (7), stanchion (8) and spring (9)

3.1.2.2 Air suspension fork structure

The vehicle's fork features both air suspension and a compression damper plus a rebound damper in some cases.

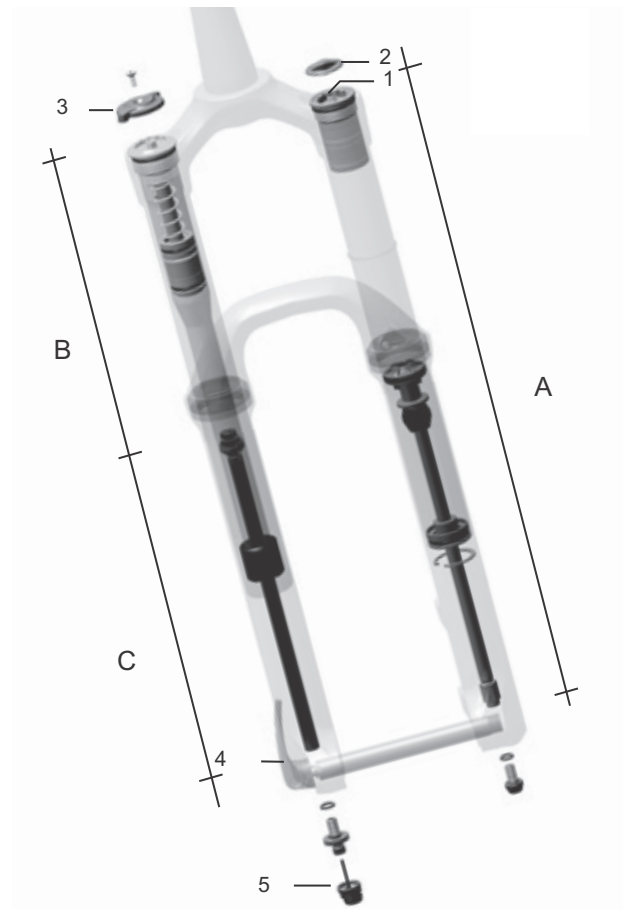

Figure 6: Example showing Yari fork

You can see the following components in the diagram: Air valve (1), valve cap (2) fork lock (3), quick release (4) and rebound damper adjuster (5) and the assembly groups: Air suspension fork (A), compression damper assembly group (B) and rebound damper assembly group (C)

3.1.2.3 Structure of the FOX rear frame damper

The rear frame damper features air suspension, a compression damper and a rebound damper.

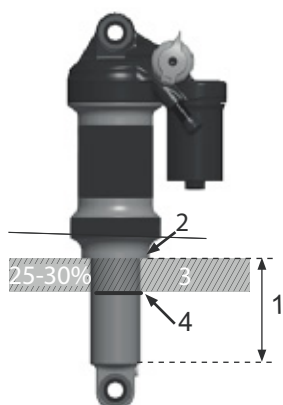

Figure 7: Example showing FOX rear frame damper

- 1 Guide rod eye
- 2 Air valve
- 3 Setting wheel
- 4 Lever
- 5 Air chamber
- 6 O-ring

3.1.2.4 Structure of the Suntour rear frame damper

The rear frame damper features air suspension, a compression damper and a rebound damper.

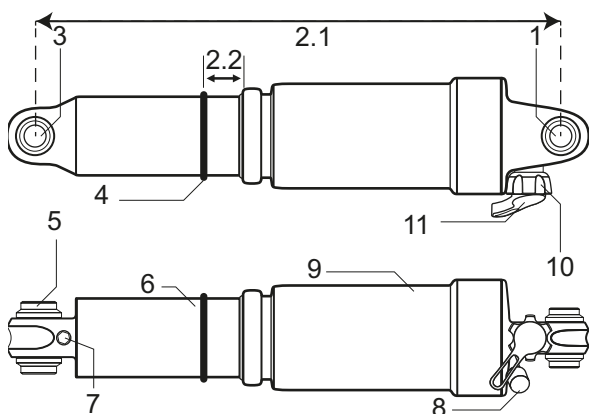

Figure 8: Example showing Suntour rear frame damper

- 1 Upper eye
- 2.1 Total damper length
- 2.2 SAG
- 3 Lower eye
- 4 O-ring
- 5 Sleeve
- 6 Damper unit
- 7 IFP (internal floating piston)

- 8 Air valve
- 9 Air chamber
- 10 Lockout lever
- 11 Rebound lever

3.1.3 Brake system

The pedelec's brake system comprises either a hydraulic:

- rim brake on the front and rear wheels
- disc brake on the front and rear wheels or
- a rim brake on the front and rear wheels and an additional back-pedal brake.

The mechanical brakes are used as an emergency stop system and bring the pedelec to a halt quickly and safely in the event of an emergency.

3.1.3.1 Rim brake

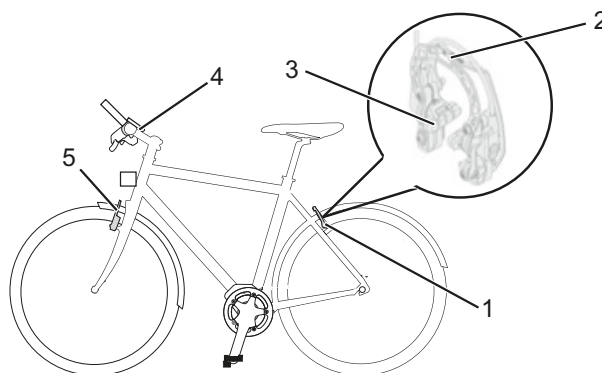

Figure 9: Rim brake components with details; Magura HS22 used as an example

- 1 Rear wheel rim brake
- 2 Brake booster
- 3 Brake lining
- 4 Handlebars with brake lever
- 5 Front wheel rim brake

The rim brake stops the wheel moving when the rider pulls the *brake lever*, causing two brake linings, positioned opposite one another, to be pressed onto the *rims*.



The hydraulic rim brake features a locking lever.

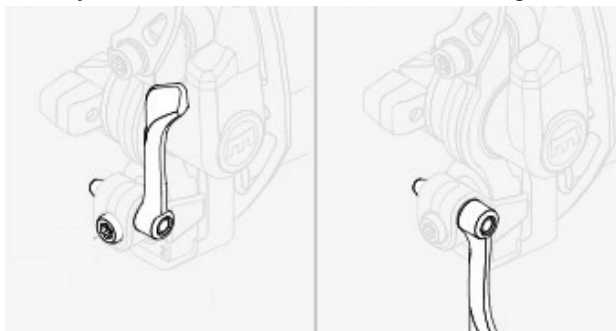

Figure 10: Rim brake locking lever, closed (1) and open (2)

The rim brake locking lever is not marked with any lettering. Only a specialist dealer may set the rim brake locking lever

3.1.3.2 Disc brake

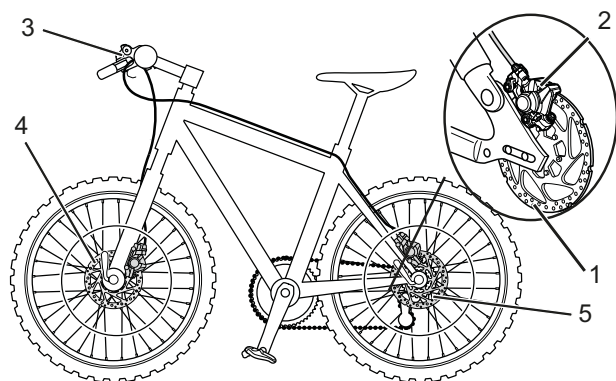

Figure 11: Pedelec brake system with a disc brake – example

- 1 Brake disc
- 2 Brake calliper with brake linings
- 3 *Handlebars with brake lever*
- 4 Front wheel brake disc
- 5 Rear wheel brake disc

On a pedelec with a disc brake, the brake disc is screwed permanently to the wheel *hub*.

The *brake lever* is pushed to increase brake pressure. The brake fluid is used to transfer pressure through the brake lines to the cylinders in the brake calliper. The braking force is boosted by a speed reduction and applied to the brake linings. These apply the brake disc mechanically. If the *brake lever* is pushed, the brake linings are pressed against the brake disc and the wheel movement is decelerated until it comes to a stop.

3.1.3.3 Back-pedal brake



Figure 12: Pedelec brake system with a back-pedal brake – example

- 1 Rear wheel rim brake
- 2 *Handlebars with brake lever*
- 3 Front wheel rim brake
- 4 *Pedal*
- 5 Back-pedal brake

The back-pedal brake stops the movement of the rear wheel when the rider pedals in the opposite direction to the direction of travel.

3.1.4 Electric drive system

The pedelec is driven by muscle power applied to the chain drive. The force which is applied by pedalling in the direction of travel drives the front chain wheel. The chain transmits the force onto the rear chain wheel and then onto the rear wheel.

You can ride the pedelec like a normal bike at any time, either by switching off the electric drive system or changing the level of assistance to Off. The same applies when the battery is empty.

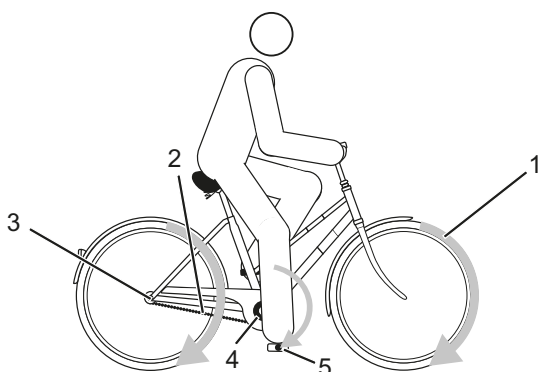

Figure 13: Diagram of drive system

- 1 Direction of travel
- 2 Chain
- 3 Rear chain wheel
- 4 Front chain wheel
- 5 Pedal

The pedelec also has an integrated electric drive system in addition to its drive system propelled by muscle power. The electric drive system is made up of 7 components:

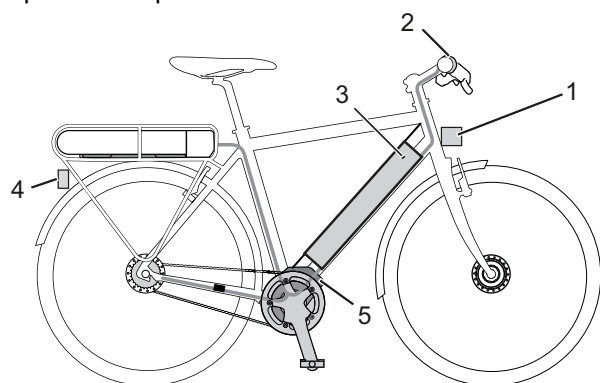
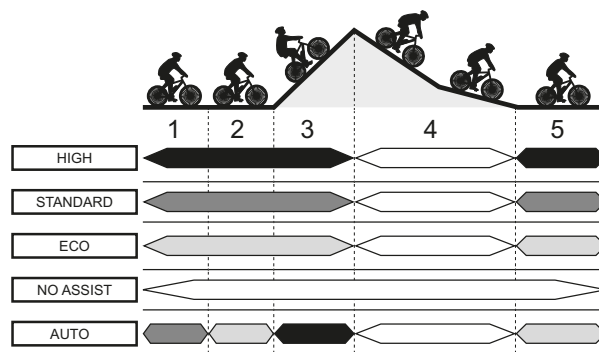

Figure 14: Diagram of electric drive system

- 1 Headlight
- 2 Display
- 3 Operating element
- 4 Rechargeable battery
- 5 Rear light
- 6 Motor
- 7 A charger designed for the battery.

As soon as the required muscle power from the rider pedalling passes a certain level, the motor is activated gently and assists the pedalling motion of the rider. The motor force is determined by the set level of assistance. The assistance depends on the force applied to the pedals by the rider. Drive system assistance is therefore only activated when the rider pedals. This applies irrespective of the selected level of assistance. The motor switches off automatically as soon as the rider no longer pedals, the temperature is outside the permitted range, there is an overload or the shut-off speed of 25 km/h has been reached. If the speed falls below 25 km/h, the assistance is automatically activated again.

The motor provides five levels of assistance: HIGH, STANDARD, ECO, NO ASSIST and OFF. The following diagram indicates the motor power when setting off (1) on a flat road (2/5), uphill (3) and downhill (4) when different levels of assistance are selected.



| Symbol | Power assistance |
|--------|------------------|
| | Strong |
| | Medium |
| | Low |
| | off |

Table 6: On-screen indicators overview

Power assistance may vary depending on the weather, road conditions, condition of the pedelec or riding style.

A push assist system can be activated. The push assist continues to drive the pedelec as long as the rider pushes the plus button on the *handlebars*. The speed can be a maximum of 6 km/h in this case.

3.1.5 Rechargeable battery

The lithium ion battery has an internal electronic protection circuit, which is specifically designed for the charger and the pedelec. The battery temperature is monitored at all times. The battery is protected against deep discharge, overcharging, overheating and short circuit. In the event of a hazard, a protective circuit switches the battery off automatically. The battery also switches to sleep mode for self-protection when not used for a longer period. The battery's service life can be extended if it is well maintained and, above all, stored at the correct temperatures. The charging capacity will decrease with age, even if the battery is maintained properly. If the operating time is severely shortened after charging, this is a sign that battery has reached the end of its useful life.

| | |
|----------------------------------|---------------|
| Transportation temperature | 5 °C - 25 °C |
| Ideal transportation temperature | 10 °C - 15 °C |
| Storage temperature | 5 °C - 25 °C |
| Ideal storage temperature | 10 °C - 15 °C |
| Charging ambient temperature | 10 °C - 30 °C |

Table 7: Rechargeable battery technical data

Three different types of pannier rack batteries can be fitted:

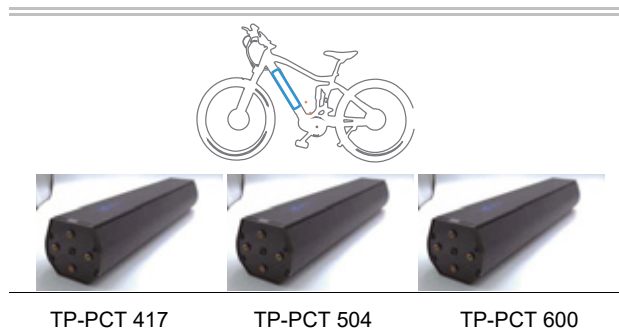

Table 8: Overview of frame batteries

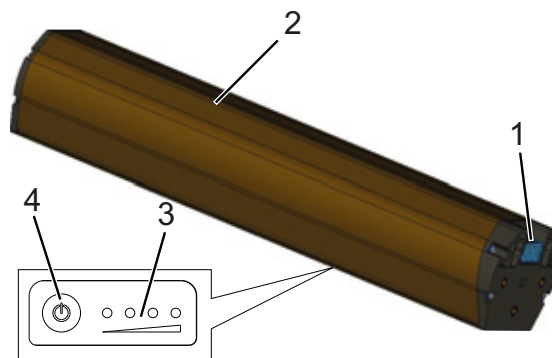

Figure 15: Details of TP-SMN-01-35Su

- 1 Charging port
- 2 Port for charger plug
- 3 Battery level indicator
- 4 On/off switch

Battery level indicator

The four LEDs on the rechargeable battery indicate the charge level. Each LED represents 25% of the charge level. The charge level for the activated battery is also shown on the *display screen*.

3.1.6 Riding light

When the riding light is activated, the *headlight* and the rear light are switched on.

3.1.7 Control panel

The rider controls the drive system on the control panel. The pedelec's battery powers the control panel when a sufficiently charged battery is inserted into the pedelec and the drive system is switched on.

| | |
|------------------------------|-----------------|
| Storage temperature | 5 °C - 25 °C |
| Charging ambient temperature | -10 °C - +60 °C |

Table 9: Control panel technical data

The control panel features 5 buttons.

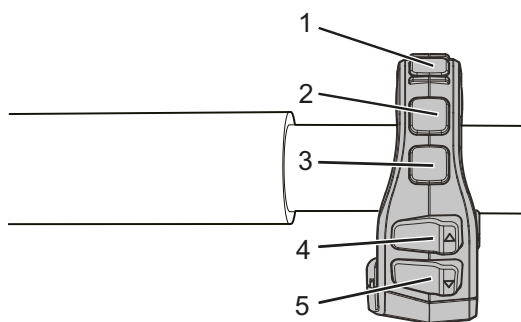

Figure 16: Details of control panel

The pedelec's battery powers the display if the display is inserted in the mount, a sufficiently charged battery is inserted into the pedelec and the drive system is switched on. The display also features a battery, so that it can also be operated separately from the drive system.

3.1.8 Display

The display screen shows all ride data. The *display* has one button and a USB port.

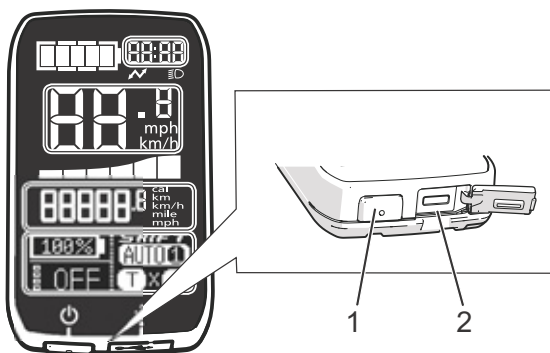

Figure 17: On-Off button (1) and USB port (2) on the display

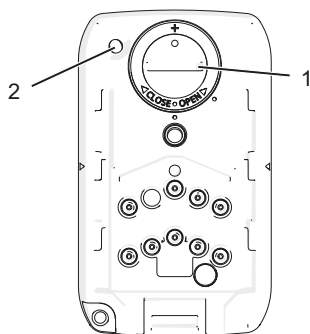

Figure 18: Display rear with battery compartment (1) and reset button (2)

The rider can switch off the drive system by removing the display.

3.2 Proper use

The pedelec must only be used in perfect, fully functional condition. National requirements may apply to the pedelec which the standard equipment may not meet. For riding on public roads, some special regulations apply in relation to the *riding light*, *reflectors* and other components.

The general laws and the regulations for the prevention of accidents and environmental protection in the respective country of use must be adhered to. All check lists and instructions for actions in these *operating instructions* met. Approved accessories can be installed by specialist staff.

Each pedelec is assigned a pedelec type, which determines its proper usage and area of use.







| City and trekking bicycles | Child's bicycles/ bicycles for young adults | Mountain bikes | Racing bicycle | Cargo bike | Folding bicycle |
|--|---|--|--|---|---|
|  |  |  |  |  |  |
| <p>City and trekking bicycles are designed for daily, comfortable use. They are suitable for riding on public roads.</p> | <p>The legal guardians of minor riders must read and understand these <i>operating instructions</i> before commissioning.</p> <p>The contents of these <i>operating instructions</i> must be communicated to the riders in an age-appropriate manner.</p> <p>The cycles for children and young adults are suitable for riding on public roads. The size of the pedelec must be checked regularly for orthopaedic reasons.</p> <p>A check must be made at least every three months to make sure that the maximum permitted total weight is being observed.</p> | <p>Mountain bikes are designed for sporting use. The design characteristics include a short wheelbase, a sitting position with the rider inclined towards the front, and a brake requiring low actuation force.</p> <p>A mountain bike is a piece of sporting equipment. It requires an adaptation period as well as physical fitness. Use requires the appropriate training; in particular riding in bends and braking should be practised.</p> <p>The strain on the rider, in particular the hands and wrists, arms, shoulders, neck and back, is accordingly high. Inexperienced riders tend to brake excessively and lose control as a result.</p> | <p>A racing bicycle is designed for fast rides on roads and paths with a good, undamaged road surface.</p> <p>A racing bicycle is a piece of sporting equipment and not a means of transport. A racing bicycle is characterised by its lightweight structure and a design which is stripped to the minimum parts required for riding.</p> <p>The frame geometry and the layout of the operating elements are designed in such a way that the bicycle can be ridden at high speeds. The frame design requires practice to ensure the ride is able to ride slowly, apply the brakes and get on and off the bike safely.</p> <p>The sitting position is athletic. The strain on the rider, in particular the hands and wrists, arms, shoulders, neck and back, is accordingly high. The sitting position therefore requires physical fitness.</p> | <p>The cargo bike is suitable for daily transportation of loads on public roads.</p> <p>The transportation of loads requires skill and physical fitness in order to balance the additional weight. The very varied loading conditions and weight distributions require special practice and skill when braking and riding in bends.</p> <p>A longer period is required to adaptation to the length, width and turning circle. You need to be cautious when riding a cargo bike. You must pay attention to the traffic on public roads and the condition of the route accordingly.</p> | <p>The folding bicycle is suitable for use on public roads.</p> <p>A folding bicycle can be folded up and is thus suitable for space-saving transportation, for example on public transport or in a car.</p> <p>The folding function of the folding bicycle makes it necessary to use smaller wheels and longer brake cables and Bowden cables. Therefore, in case of an increased load, a reduction in riding stability and braking power, diminished comfort and reduced durability are to be expected.</p> |

Table 10: Proper use

3.3 Improper use

Failure to adhere to the proper use poses a risk of personal injury and material damage. The pedelec is not suitable for the following uses:

- when the electrical drive has been manipulated
- riding with a damaged or incomplete pedelec
- riding over steps
- riding through deep water
- lending the pedelec to untrained riders
- carrying other people
- riding with excessive baggage
- riding with no hands
- riding on ice and snow
- improper servicing
- improper repair
- tough areas of use, such as professional competitions
- stunt riding or acrobatics.

| City and trekking bicycles | Child's bicycles/ bicycles for young adults | Mountain bikes | Racing bicycle | Cargo bike | Folding bicycle |
|--|---|--|--|---|---|
|  |  |  |  |  |  |
| City and trekking bicycles are not sports bicycles. If used for sports, the rider can expect reduced riding stability and diminished comfort | Cycles for children and young adults are not toys. | Mountain bikes must be retrofitted with lighting, a guard and other fittings as specified by national laws and regulations before they are used on public roads. | Racing bikes must be retrofitted with lighting, a guard and other fittings as specified by national laws and regulations before they are used on public roads. | A cargo bike is not a touring bicycle or a sports bicycle. | The folding bicycle is not a sports bicycle. |

Table 11: Information on incorrect use

3.4 Technical data

3.4.1 Pedelec

| | |
|-------------------------------------|-----------------|
| Transportation temperature | 5 °C - 25 °C |
| Ideal transportation temperature | 10 °C - 15 °C |
| Storage temperature | 5 °C - 25 °C |
| Ideal storage temperature | 10 °C - 15 °C |
| Operation temperature | 5 °C - 35 °C |
| <i>Work environment</i> temperature | 15 °C - 25 °C |
| Charging temperature | 10 °C - 30 °C |
| Power output/system | 250 W (0.25 kW) |
| Shut-off speed | 25 km/h |

Table 12: Pedelec technical data

3.4.2 Panasonic GX Power Motor

| | |
|-------------------------|---------|
| Weight | 3200g |
| Nominal voltage | 36 V DC |
| Max. torque | 60 Nm |
| Continuous power rating | 250 W |
| Assistance up to | 25 km/h |

Table 13: Panasonic GX Power Motor technical data

3.4.3 Panasonic TP-PCT rechargeable battery

| | |
|----------------|--------------|
| Voltage | 36 V |
| Capacity | 11.6 Ah |
| Energy content | 417 Wh |
| Weight | About 3.3 kg |
| Capacity | 14 Ah |
| Energy content | 504 Wh |
| Weight | About 3.3 kg |
| Capacity | 17.5 Ah |
| Energy content | 630 Wh |
| Weight | About 3.8 kg |

Table 14: Panasonic TP-PCT rechargeable battery technical data

3.4.4 USB port

| | |
|------------------|--------------|
| Charge voltage | 5 V |
| Charging current | Max. 1000 mA |

Table 15: USB port technical data

3.4.5 Display

The display has a 3 V coin cell.

3.4.6 Control device

| | |
|-----------------------|--------------|
| Weight (g) | About 0.4 kg |
| Nominal voltage | 36 V DC |
| Protection class | IPX5 |
| Operating temperature | -10 - +40 °C |
| Storage temperature | -20 - +50 °C |

Table 16: Control device technical data

3.4.7 Emissions

| | |
|--|------------------------|
| A-weighted emission sound pressure level | < 70 dB(A) |
| Total vibration level for the hands and arms | < 2.5 m/s ² |
| Highest effective value of weighted acceleration for the entire body | < 0.5 m/s ² |

Table 17: Emissions from the pedelec*

*The safety requirements as per Electromagnetic Compatibility Directive 2014/30/EU have been met. The pedelec and the charger can be used in residential areas without restriction.

3.4.8 Tightening torque

| | |
|--|---------------|
| Axle nut tightening torque | 35 Nm - 40 Nm |
| Handlebars clamping screw maximum tightening torque* | 5 Nm - 7 Nm |

Table 18: Tightening torque values

*if there is no other data on the component

3.5 Description of controls and screens

3.5.1 Handlebars

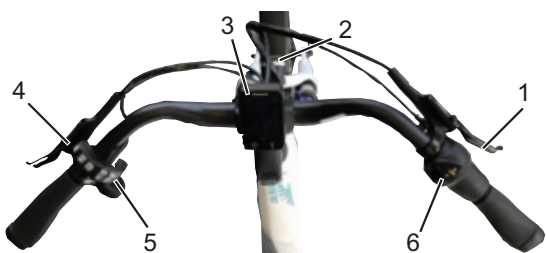

Figure 19: Detailed view of pedelec from rider position, example

- 1 Rear brake lever
- 2 Headlight
- 3 Display
- 4 Front brake lever
- 5 Control panel
- 6 Gear shift

3.5.2 Display

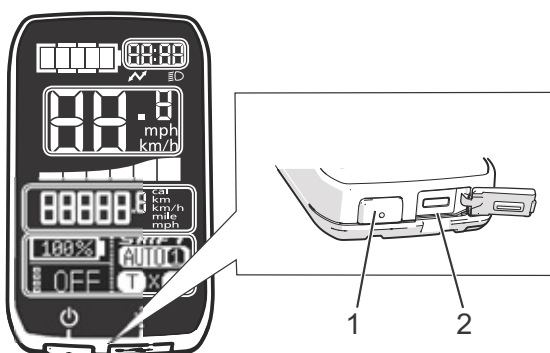

Figure 20: Display front

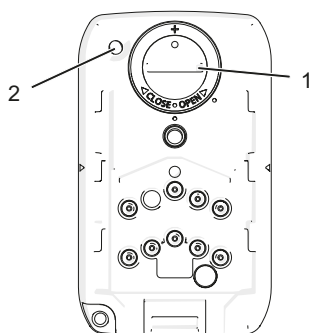

Figure 21: Display back

| Use | |
|-----|--------------------------|
| 1 | Front: On-Off button |
| 2 | USB port front |
| 1 | Battery compartment rear |
| 2 | Reset button rear |

The operating element display has seven on-screen indicators:



Figure 22: On-screen indicators overview

| Use | |
|-----|-------------------------------|
| 1 | Power assistance indicator |
| 2 | Light indicator |
| 3 | Clock |
| 4 | Battery level indicator |
| 5 | Speed indicator |
| 6 | Journey information indicator |
| 7 | On-Off indicator |
| 8 | USB indicator |
| 9 | System messages indicator |

Table 19: On-screen indicators overview

3.5.2.1 Current speed

You can select whether the speed is displayed in kilometres or miles in the system settings.

3.5.2.2 Battery level indicator

The battery level indicator does not display the charge level for the coin cell inside the control device indicator unit; it indicates the pedelec's rechargeable battery charge level.

You can also check the LEDs on the pedelec's rechargeable battery to verify its charge level.

| Symbol | Lit | Charge level |
|--------|-----------|--------------|
| | 5 | 81 - 100% |
| | 4 | 61 - 80% |
| | 3 | 41 - 60% |
| | 2 | 21 - 40% |
| | 1 | 11 - 20% |
| | 1 flashes | 1 - 10% |

3.5.2.3 Level of assistance

The rider can select from five levels of assistance by pressing on the levels of assistance button. The higher the level of assistance, the more the drive system assists the rider when pedalling. The following levels of assistance are available:

| Level of assistance | Use |
|---------------------|--|
| HIGH | Powerful assistance |
| STANDARD | Normal assistance |
| ECO | Low assistance |
| NO ASSIST | When the drive system is switched on, the motor assistance is switched off. |
| AUTO | In the automatic level of assistance, the system automatically chooses the appropriate assistance for the riding conditions. |

Table 20: Overview of levels of assistance

3.5.2.4 Function display

The function display shows two different items of information:

- journey information and
- System messages.

3.5.2.5 Journey information

The pedelec provides six types of journey information on the function display. The displayed journey information can be switched.

| Screen display | Function |
|----------------------------|--|
| TRIP | Distance travelled |
| AVG | Average speed |
| MAX | Maximum speed of a journey |
| ODO | Total distance travelled |
| RANGE | Estimated range of the available battery charge, calculated based on the most recent riding mode. The range is an estimated value since the remaining battery capacity is calculated based on consumption. |
| REMAINING BATTERY CAPACITY | Battery level as a percentage. |

Table 21: Journey information

| Screen display | Symbol with 2 indicators | Symbol with 4 indicators |
|----------------------------|--------------------------|--------------------------|
| TRIP | | |
| AVG | | |
| MAX | | |
| ODO | | |
| RANGE | | |
| REMAINING BATTERY CAPACITY | | |

Table 22: Journey information

3.5.2.6 System settings and data

In order to see the system settings and data, the rider has to *call up the system settings*. The rider can change the values of the system settings.

| Screen display | Function |
|----------------|--|
| LANGUAGE | Changing the language |
| CONTRAST | Changing the display contrast |
| BRIGHTNESS | Change display screen brightness |
| UNIT | Changing the unit of measure for speed |
| WHEEL | Adjusting the tyre size |
| ODO INPUT | Changing the distance travelled |
| CLOCK | Setting the clock |

Table 23: Changeable system settings

3.5.2.7 System message

The drive system monitors itself continuously and if an error is detected, it is indicated by a system message. The system may switch off automatically depending on the type of error. There is a table with all the system messages at the end of the chapter *Maintenance*.

3.5.3 Control panel

The control panel features 5 buttons.

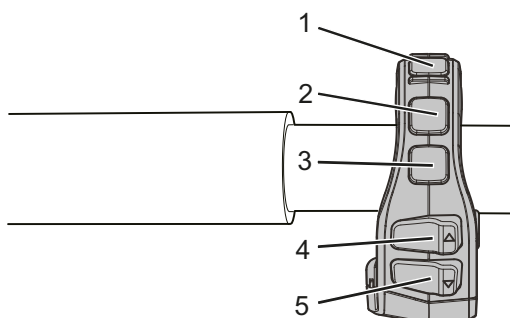

Figure 23: Display details

| Designation | Use |
|----------------------|---|
| 1 Push assist button | Movement can be assisted up to 6 km/h if the electric bicycle is being pushed with a heavy load. |
| 2 Night mode button | Backlights the indicator unit. Whenever the headlight is powered via the electric bicycle battery, the rear light will also light up and vice versa. This depends on local regulations. |
| 3 Info button | Switches between indicator elements, such as the distance travelled. |
| 4 Up button | Selects the assistance mode between [HIGH], [STANDARD], [ECO], [NO ASSIST] and [AUTO] |
| 5 Down button | Selects the assistance mode between [HIGH], [STANDARD], [ECO], [NO ASSIST] and [AUTO] |

Table 24: Display overview

3.6 Environmental requirements

The pedelec is designed for outdoor use up to altitudes of 2,000 m.

You can be ride the pedelec within a temperature range between 5 °C and 35 °C. The drive system is limited in its performance outside this temperature range.

| | |
|--------------------------------------|--------------|
| Optimal operating temperature | 5 °C - 35 °C |
|--------------------------------------|--------------|

During winter use, especially at temperatures below 0 °C, we recommend that you don't insert a battery charged and stored at room temperature into the pedelec until just before setting off. We

recommend using thermal protection sleeves when riding longer distances in the cold.

As a general rule, you should avoid temperatures under -10 °C or over +60 °C.

You must also keep within the following temperature ranges:

| | |
|------------------------------|----------------|
| Transportation temperature | -10 °C - 50 °C |
| Storage temperature | -10 °C - 50 °C |
| Work environment temperature | 15 °C - 25 °C |
| Charging temperature | 0 °C - 40 °C |

Table 25: Pedelec technical data

The nameplate contains symbols for the pedelec's area of use. Check what roads and paths you may use before you ride the pedelec for the first time.





















| Area of use | City and trekking bicycles | Child's bicycles/ bicycles for young adults | Mountain bikes | Racing bicycle | Cargo bike | Folding bicycle |
|--|---|---|--|---|--|--|
|  1 |  Suitable for tar-macked and paved roads. |  Suitable for tar-macked and paved roads. |  |  Suitable for tar-macked and paved roads. |  Suitable for tar-macked and paved roads. |  Suitable for tar-macked and paved roads. |
|  2 | Suitable for tar-macked roads, cycle paths and firm gravel paths and roads, and longer sections with moderate slopes and jumps up to 15 cm. | Suitable for tar-macked roads, cycle paths and firm gravel paths and roads, and longer sections with moderate slopes and jumps up to 15 cm. | Suitable for tar-macked roads, cycle paths and easy to demanding off-road riding, sections with moderate slopes and jumps up to 61 cm. | Suitable for tar-macked roads, cycle paths and firm gravel paths and roads, and longer sections with moderate slopes and jumps up to 15 cm. | | |
|  3 | | | Suitable for tar-macked roads, cycle paths and easy to demanding off-road riding, limited downhill use and jumps up to 122 cm. | | | |
|  4 | | | Suitable for tar-macked roads, cycle paths and easy to extremely difficult off-road riding, unlimited downhill use and any jumps | | | |

Table 26: Area of use

The pedelec is unsuitable for the following areas of use:

| Area of use | City and trekking bicycles | Child's bicycles/ bicycles for young adults | Mountain bikes | Racing bicycle | Cargo bike | Folding bicycle |
|--|---|---|---|---|---|---|
|  1 |  Never drive off-road or perform jumps. |  Never drive off-road or perform jumps. |  |  Never drive off-road or perform jumps. |  Never drive off-road or perform jumps. |  Never drive off-road or perform jumps. |
|  2 | Never drive off-road or perform jumps over 15 cm. | Never drive off-road or perform jumps over 15 cm. | Never drive off-road or perform jumps over 15 cm. | Never drive off-road or perform jumps over 15 cm. | | |
|  3 | | | Never ride downhill or perform jumps over 61 cm. | | | |
|  4 | | | Never traverse extremely difficult off-road terrain or perform jumps over 122 cm. | | | |

4 Transporting and storing



4.1 Physical transport characteristics

4.1.1 Dimensions during transportation

There was no information relating to the box dimensions at the time of going to press. You'll find the information in the latest *operating instructions* on the retailer portal.

4.1.2 Transport weight

There was no information relating to the box dimensions at the time of going to press. You'll find the information in the latest *operating instructions* on the retailer portal.

4.1.3 Designated handles/lifting points

There was no information relating to the box dimensions at the time of going to press. You'll find the information in the latest *operating instructions* on the retailer portal.

4.2 Transporting



Crash caused by unintentional activation

There is a risk of injury if the drive system is activated unintentionally.

- ▶ Remove the battery before the pedelec is transported.

Risk of fire and explosion due to high temperatures

Excessively high temperatures will damage the battery. Batteries may self-ignite and explode.

- ▶ Never expose batteries to sustained direct sunlight.



Oil leak if no transport securing device

The brake securing device prevents the brakes from being applied accidentally during transportation. This could cause irreparable damage to the brake system or an oil leak, which will harm the environment.

- ▶ Never push the *brake lever* when the wheel has been dismantled.
- ▶ Always use the transport securing system when transporting dismantled wheels.

Notice

Oil and grease may leak from the pedelec if it is lying flat.

If the shipping box with a pedelec is lying flat or standing on one end, it does not provide the *frame* and wheels with adequate protection against damage.

- ▶ Transport the pedelec in an upright position only.

Bicycle rack systems which use the *handlebars* or *frame* to hold the pedelec in an upside-down position exert inadmissible forces on its components during transportation. This can cause the supporting parts to break.

- ▶ Never use bicycle rack systems which use the pedelec's *handlebars* or *frame* to hold it in an upside-down position.
- ▶ Take into account the weight of the ready-to-use pedelec when transporting it.
- ▶ Remove the *display screen* and the batteries before transporting the pedelec.
- ▶ Protect the electrical components and connections on the pedelec from the weather conditions with suitable protective covers.
- ▶ Remove accessories such as drinking bottles before transporting the pedelec.
- ▶ You must use a suitable bicycle rack system when transporting by car.

Notice

The specialist dealer will advise you on how to select a suitable rack system properly and how to use it safely.

- ▶ If you ship the pedelec, we recommend that you have it partially dismantled and packaged properly by the specialist dealer.
- ▶ Transport the pedelec in a dry, clean position where it is protected from direct sunlight.

4.2.1 Transporting the battery

Batteries are subject to hazardous goods regulations. Undamaged batteries may be transported by private persons in road traffic.

Commercial transport requires compliance with regulations concerning packaging, labelling and the transportation of hazardous goods. Open contacts must be covered and the battery securely packaged.

4.2.2 Shipping the battery

The battery is considered a hazardous good and only trained persons may pack and ship a battery. Contact your specialist dealer regarding any battery shipment.

4.2.3 Using the brake transport securing system

- ▶ Insert the transport securing devices between the brake linings.
- ⇒ The transport securing device is squeezed between the two linings.

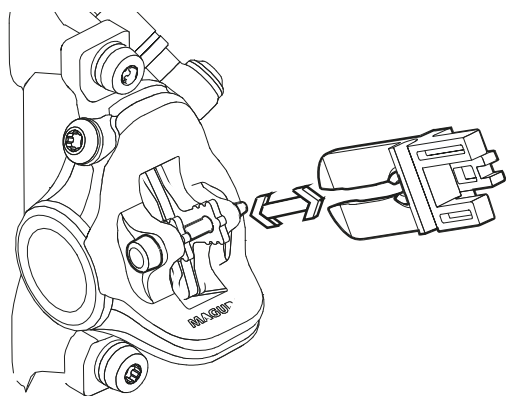

Figure 24: Fastening the transport securing device

4.3 Storing

CAUTION

Risk of fire and explosion due to high temperatures

Temperatures over 60 °C can also cause liquid to leak from the battery and the battery will become damaged. Batteries may self-ignite and explode.

- ▶ Protect batteries against heat.
- ▶ Never store in proximity to hot or flammable objects.
- ▶ Never expose batteries to continuous direct sunlight and never store near heaters.

Notice

Oil and grease may leak from the pedelec if it is lying flat.

If the shipping box with a pedelec is lying flat or standing on one end, it does not provide the *frame* and wheels with adequate protection against damage.

- ▶ Store the pedelec in an upright position only.
- ✓ If the pedelec features a hydraulic seat post, fix only the lower seat post or the frame into a fitting stand to prevent damage to the upper seat post and the seat post lever.
- ✓ Never place a pedelec with a hydraulic seat post upside down on the floor; otherwise you, will damage the seat post lever.
- ✓ Store the pedelec, battery and charger in a dry, clean location.

| | |
|-------------------------------------|---------------|
| Storage temperature | 5 °C - 25 °C |
| Optimum pedelec storage temperature | 10 °C - 15 °C |
| Optimum battery storage temperature | 22 °C - 26 °C |

Table 27: Storage temperature for batteries, the pedelec and charger

4.3.1 Break in operation

Notice

The battery discharges when not in use. This can cause irreparable damage to the battery.

- ▶ The battery must be recharged every 3 months.

The battery may become damaged if it is connected permanently to the charger.

- ▶ Never connect the battery to the charger permanently.

The display battery discharges when it is not in use. This can cause it to be irreparably damaged.

- ▶ Recharge the display battery for at least 1 hour every 3 months.

If the pedelec is to be removed from service for longer than four weeks, for the winter, for example, you need to prepare it for a break in operation.

4.3.1.1 Preparing a break in operation

- ✓ Remove battery from the pedelec.
- ✓ Charge battery to around 30%–60%.
- ✓ The pedelec needs to be cleaned with a damp cloth and preserved with wax spray. Never wax the friction surfaces of the brake.
- ✓ Before longer periods without use, it is recommendable to have your specialist dealer carry out an inspection and basic cleaning and apply preservative agent.

4.3.1.2 Taking out of operation

- ▶ Store the pedelec, battery and charger in a dry, clean environment. We recommend storing them in uninhabited rooms with smoke alarms. Dry locations with an ambient temperature of about 20 °C are ideal.
- ▶ Recharge the display battery for at least 1 hour every 3 months.
- ▶ Check the battery level after 8 weeks. If only one LED on the battery level indicator lights up, recharge the battery to around 60%.



5 Assembly

WARNING

Injury to the eyes

Problems may arise if the settings are not made to components properly and you may sustain serious injuries as a result.

- ▶ Always wear safety glasses to protect your eyes during assembly.

CAUTION

Crushing caused by unintentional activation

There is a risk of injury if the drive system is activated unintentionally.

- ▶ Remove the battery if it is not absolutely necessary for assembly

- ✓ Assemble the pedelec in a clean, dry environment.

The *work environment* temperature should be between 15 °C and 25 °C.

| | |
|------------------------------|---------------|
| Work environment temperature | 15 °C - 25 °C |
|------------------------------|---------------|

Table 28: Work environment temperature

- ✓ If a fitting stand is used, it must be approved for a maximum weight of 30 kg.
- ✓ We recommend that you always disconnect the battery from the pedelec when using the fitting stand to reduce weight.

5.1 Required tools

The following tools are required to assemble the pedelec:

- Knife
- Hexagon socket spanner 2 (2.5 mm, 3 mm, 4 mm, 5 mm, 6 mm and 8 mm)
- Torque wrench with working range between 5 and 40 Nm
- Twelve-point square socket T25
- Ring spanner (8 mm, 9 mm, 10 mm), 13 mm, 14 mm and 15 mm) and
- Cross, flat head and ordinary screwdriver.

5.2 Unpacking

CAUTION

Hand injuries caused by cardboard packaging

The shipping carton is closed with metal staples. There is a risk of puncture wounds and cuts when unpacking and crushing the packaging.

- ▶ Wear suitable hand protection.
- ▶ Remove the metal staples with pliers before the shipping carton is opened.

The packaging material consists mainly of cardboard and plastic film.

- ▶ The packaging has to be disposed of in accordance with the regulations of the authorities.

5.2.1 Scope of delivery

The pedelec was completely assembled in the factory for test purposes and then dismantled for transportation.

The pedelec is 95–98% pre-assembled. The scope of delivery includes:

- the pre-assembled pedelec
- the front wheel
- the pedals
- quick release (optional)
- the charger
- the *operating instructions*.

The battery is supplied separately from the pedelec.

5.3 Commissioning

CAUTION

Risk of fire and explosion due to incorrect charger

Batteries which are recharged with an unsuitable charger may become damaged internally. This may result in fire or an explosion.

- ▶ Only ever use the battery with the supplied charger.
- ▶ Mark the supplied charger clearly to prevent mix-ups – with the pedelec *frame number* or *type number*, for example.

Burns from hot drive

The drive cooler can become extremely hot during use. Contact may cause burns.

- ▶ Leave the drive unit to cool before cleaning.

Only trained specialist staff may perform initial commissioning since initial commissioning of the pedelec requires special tools and specialist knowledge.

Experience has shown that a pedelec which has not yet been sold is automatically handed to end users as soon as it appears ready to ride.

- ▶ For this reason, every pedelec must be prepared, so that it is fully ready for use immediately after being assembled.
- ▶ All assembly work described in the assembly report (see appendix) must be performed to ensure the pedelec is ready to ride. It describes all safety-relevant inspections, tests and maintenance tasks for the pedelec in a separate list.
- ▶ Complete an assembly report for quality assurance purposes.

5.3.1 Checking the battery

WARNING

Risk of fire and explosion due to faulty battery

The safety electronics may fail if the battery is damaged or faulty. The residual voltage can cause a short circuit. The battery may self-ignite and explode.

- ▶ Never charge a faulty battery.

The battery must be checked before it is charged for the first time.

- ▶ Press the *On-Off button (battery)*.
- ⇒ If none of the LEDs on the battery level indicator light up, the battery may be damaged.
- ⇒ The battery may be fully charged if at least one, but not all, of the LEDs on the battery level indicator is lit up.
- ▶ Once the battery has been charged, insert it into the pedelec.

5.3.2 Initial use of the display

The display features an integrated coin cell (3 V) for the time display memory. When the display is delivered, there is plastic protective shield in the battery compartment to ensure the coin cell does not discharge. Remove this plastic shield before you use the display for the first time.

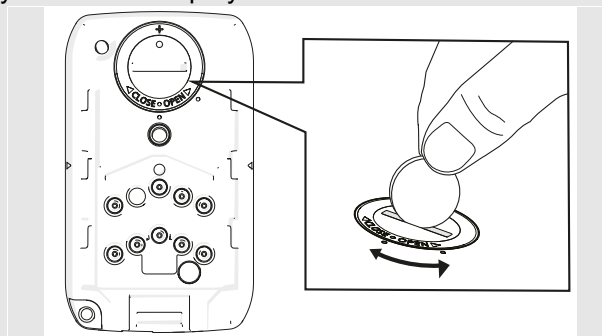

Figure 25: Open battery compartment with a coin on the display rear

- ▶ Use a coin to turn the battery compartment latching cover on the display rear in a anti-clockwise direction.
- ⇒ The coin cell compartment will open.
- ▶ Remove the coin cell.
- ▶ Remove the plastic shield from the minus pole side.
- ▶ Dispose of the plastic shield in the correct manner.
- ▶ Insert the coin cell into the battery compartment.
- ▶ Turn the latching cover clockwise.
- ⇒ The battery compartment is now locked.

Notice

If the cover does not firmly latch into position, the indicator unit will not work properly since it will cause a malfunction caused by water penetrating the compartment, for example.

5.3.3 Installing the wheel in the Suntour fork

Only applies to pedelecs with this equipment

5.3.3.1 Installing the wheel with screw-on axle (15 mm)

- ▶ Insert the axle completely on the drive side.

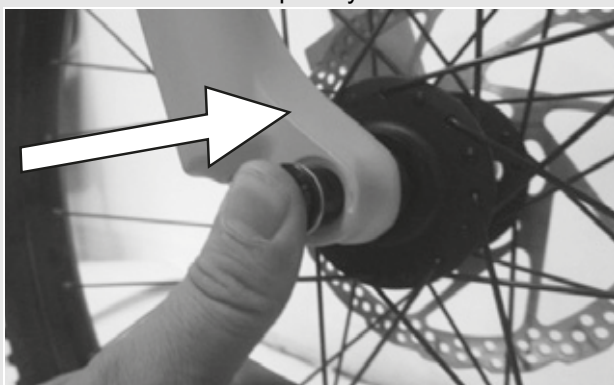

Figure 26: Fully inserting the axle

- ▶ Tighten the axle to 8-10 Nm with a 5 mm hexagon socket spanner.

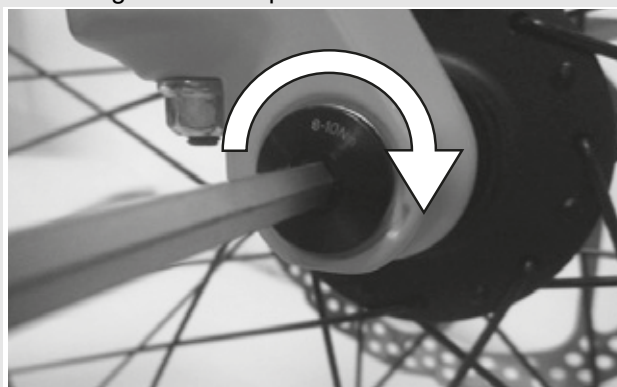

Figure 27: Tightening the axle

- ▶ Insert the securing screw on the non-drive side.

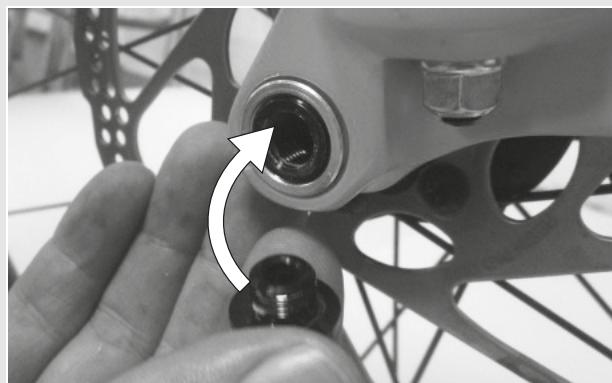

Figure 28: Pushing the quick release lever into the axle

- ▶ Tighten the securing screw with a 5 mm hexagon socket spanner to 5–6 Nm.

⇒ The lever is mounted.

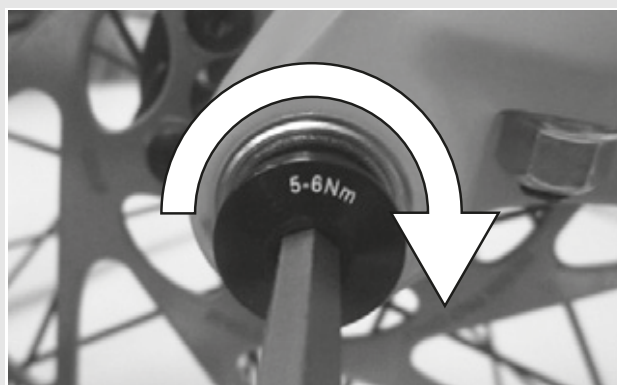

Figure 29: Tightening the securing screw

5.3.3.2 Installing the wheel with screw-on axle (20 mm)

- ▶ Insert the axle completely on the drive side.

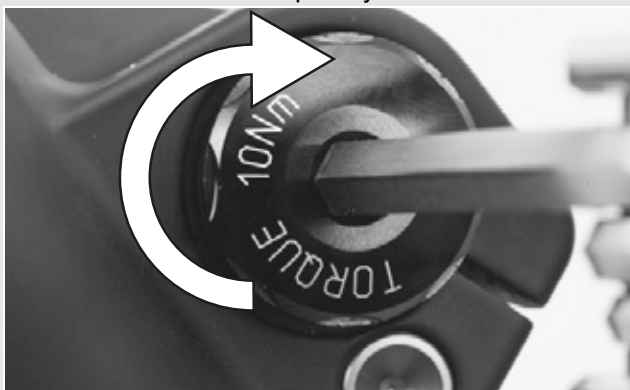

Figure 30: Tightening the inserted axle

- ▶ Tighten the securing clip with a 4 mm hexagon socket spanner to 7 Nm.



Figure 31: Tightening the axle

5.3.3.3 Installing the wheel with a quick release axle

CAUTION

Crash caused by loose quick release axle

A faulty or incorrectly installed quick release axle may become caught in the brake disc and block the wheel. This will cause a crash.

- ▶ Never fit a defective quick release axle.

Crash caused by faulty or incorrectly installed quick release axle

The brake disc becomes very hot during operation. Parts of the quick release axle may become damaged as a result. The quick release axle becomes loose. This will cause a crash with injuries.

- ▶ The quick release axle and the brake disc must be opposite one another.

CAUTION

Crash caused by incorrectly set quick release axle

Insufficient clamping force will cause a detrimental transmission of force. The suspension fork or the quick release axle may break. This will cause a crash with injuries.

- ▶ Never fasten a quick release axle with a tool, such as a hammer or pliers.

- ▶ Insert the axle into the hub on the drive side. Clamping version II.

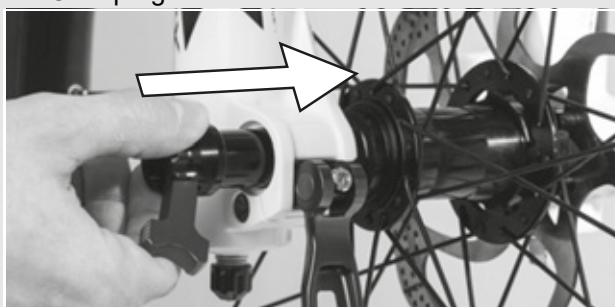

Figure 32: Pushing the axle into the hub

- ▶ Tighten the axle with the red handle.

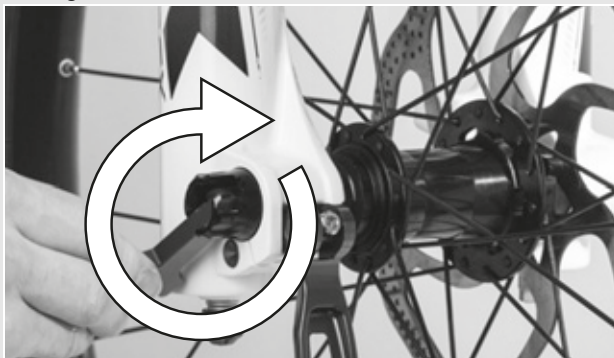

Figure 33: Tightening the axle

- ▶ Push the quick release lever into the axle.

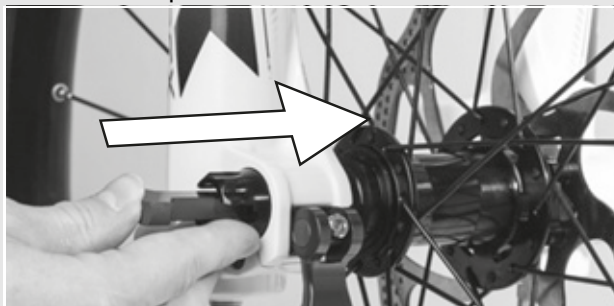

Figure 34: Pushing the quick release lever into the axle

- ▶ Reverse the quick release lever.

⇒ The lever is secured.



Figure 35: Securing the lever

- ▶ Check the position and clamping force of the quick release lever. The quick release lever must be flush with the lower housing. You must be able to see a slight impression on the palm of your hand when you close the quick release lever.



Figure 36: Perfect position for the clamping lever

- ▶ Use a 4 mm hexagon socket spanner to adjust the clamping lever clamping force if required. Afterwards, check the quick release lever position and clamping force.

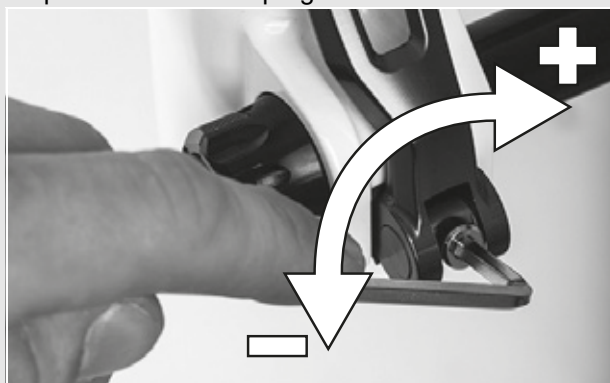

Figure 37: Adjusting the quick release clamping force

5.3.4 Installing the wheel with a quick release



Crash caused by unfastened quick release

A faulty or incorrectly installed quick release may become caught in the brake disc and block the wheel. This will cause a crash.

- ▶ Never fit a defective quick release.

Crash caused by faulty or incorrectly installed quick release

The brake disc becomes very hot during operation. Parts of the quick release may become damaged as a result. The quick release comes loose. This will cause a crash with injuries.

- ▶ The front wheel quick release lever and the brake disc must be situated on opposite sides.

Crash caused by incorrectly set clamping force

Excessively high clamping force will damage the quick release and cause it to lose its function.

Insufficient clamping force will cause a detrimental transmission of force. The suspension fork or the quick release may break. This will cause a crash with injuries.

- ▶ Never fasten a quick release using a tool (e.g. hammer or pliers).
- ▶ Only use the clamping lever with the specified set clamping force.

- ▶ Before installing, ensure that the quick release flange is extended. Open the lever completely.

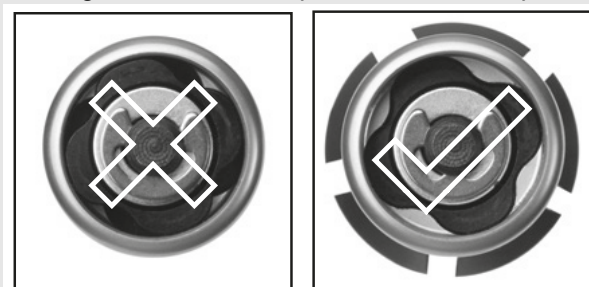

Figure 38: Closed and opened flange

- ▶ Push in the quick release until you hear a clicking sound. Make sure that the flange is extended.



Figure 39: Pushing the quick release in

- ▶ Adjust the clamping with a half-open clamping lever until the flange reaches the fork end.

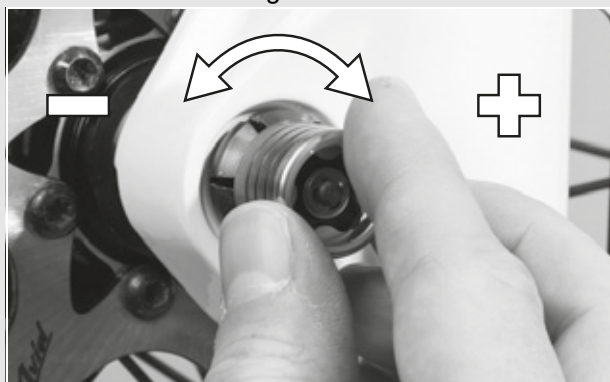

Figure 40: Adjusting the clamping

- ▶ Fully close the quick release. Check the quick release to ensure it is firmly in place and adjust on the flange if necessary.

⇒ The lever is secured.



Figure 41: Closing the quick release

5.3.5 Installing the wheel in the FOX fork

Only applies to pedelecs with this equipment

5.3.5.1 Wheel with quick release (15 mm)

The procedure for installing the 15 x 100 mm and 15 x 110 mm quick releases is the same.

- ▶ Place the front wheel in the fork ends of the fork. Push the axle through the fork end on the non-drive side and hub.

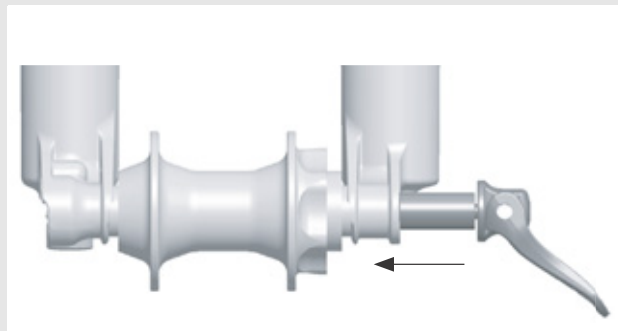

Figure 42: Pushing the quick release in

- ▶ Open the axle lever.
- ▶ Turn the axle five to six complete revolutions clockwise into the axle nut.
- ▶ Close the quick release lever. The lever must be tensioned to the point that it leaves a mark on your hand.
- ▶ The lever must be 1 to 20 mm ahead of the fork leg in the closed position.

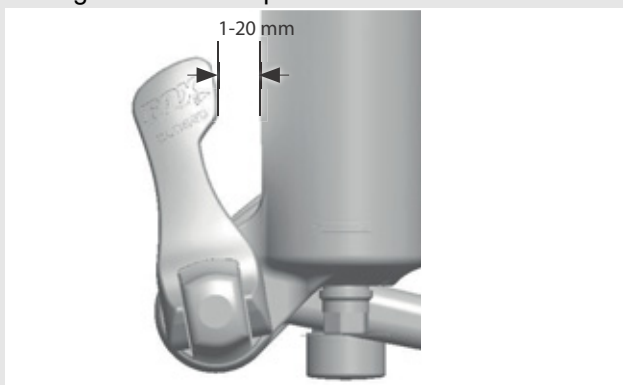

Figure 43: Spacing between lever and fork leg

- ⇒ If the lever is tensioned too little or too much when closed in the recommended position (1 to 20 mm in front of the fork), the quick release must be adjusted.

5.3.5.2 Adjusting the FOX quick release

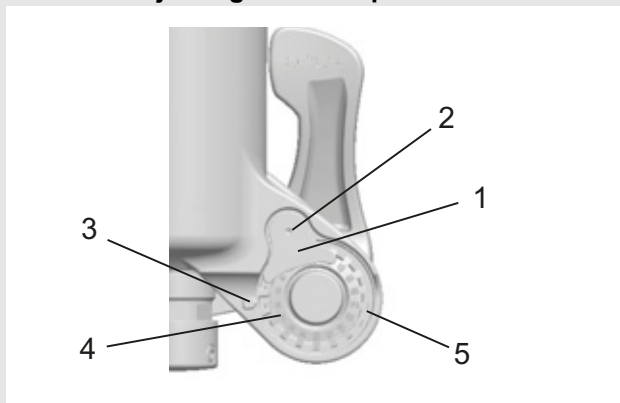

Figure 44: Structure of quick release from rear with (1) axle nut lock, (2) axle nut securing screw, (3) directional arrow, (4) axle setting value and (5) axle nut

- ▶ Record the axle setting value (4) indicated by the directional arrow (3).
- ▶ Loosen the axle nut securing screw (2) with a 2.5 mm hex key by approx. four revolutions, but do not remove the screw completely.
- ▶ Turn the quick release lever to the open position and loosen the axle by approx. four revolutions.
- ▶ Press the axle inward from the side of the open lever. This pushes out the axle nut securing screw so that you can turn it out of the way.
- ▶ Push the axle further forward and turn the axle nut clockwise to increase the lever tension or anti-clockwise to reduce the lever tension.
- ▶ Reinsert the axle nut lock and tighten the screw to 0.9 Nm (8 in-lb).
- ▶ Repeat the steps for installing the axle to check proper installation and correct adjustment.

5.3.5.3 Installing the wheel with Kabolt axles

The procedure for installing the 15 x 100 mm and 15 x 110 mm Kabolt axles is the same.

- ▶ Place the front wheel in the fork ends of the fork. Push the Kabolt axle through the fork end on the non-drive side and hub.

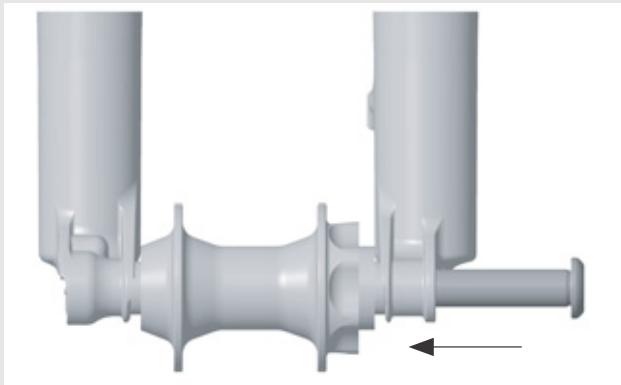

Figure 45: Pushing the Kabolt axle in

- ▶ Tighten the Kabolt axle screw to 17 Nm (150 in-lb) with a 6 mm hex key.

5.3.5.4 Checking the stem and handlebars

Checking connections

- ▶ Stand in front of the pedelec to check whether the handlebars, stem and fork steerer are firmly attached to one another. Clamp the front wheel between your legs. Grasp the handlebar grips. Try to twist the handlebars towards the front wheel.

⇒ The stem must not move or twist.

Firm hold

- ▶ Place your entire body weight on the handlebars with the quick release lever closed to check that the stem is firmly in place.
- ⇒ The handlebars shaft must not move downwards in the fork steerer.
- ▶ If the handlebars shaft should move in the fork steerer, increase the quick release lever tensioning. To do so, turn the knurled nut slightly in a clockwise direction with the quick release lever open.
- ▶ Close the lever and check the stem is firmly in position.

Checking the headset backlash

- ▶ To check the handlebar headset backlash, close the quick release lever on the stem. Place the fingers of one hand on the upper headset cup, pull the front wheel brake with the other hand and try to push the pedelec backwards and forwards.
- ▶ The headset cup halves must not move towards one another while you are doing this. Note that there may be noticeable backlash due to worn-out bearing bushes or brake lining backlash in suspension forks and disc brakes.
- ▶ If there is headset backlash in the steering headset, you must adjust it as soon as possible; otherwise, the headset will become damaged. You must make the adjustment as described in the stem manual.

5.3.6 Pedelec sale

- ▶ Complete the data sheet on the *operating instructions* envelope.
- ▶ Note down the key manufacturer and its number.
- ▶ Adjust the pedelec to the rider.
- ▶ Set the *stand* and the *shifter*, and show the purchaser the settings.
- ▶ Instruct the operator or rider on how to use all the pedelec's functions.

6 Operation

6.1 Risks and hazards



WARNING

Injuries and death caused by other road users

Other road users, trucks, cars or pedestrians often underestimate the speed of pedelecs. Likewise, other road users frequently do not see pedelecs. This may cause a crash with serious injuries or even death.

- ▶ Wear a cycling helmet and high-visibility, reflective clothing.
- ▶ Always take a defensive approach to riding.
- ▶ Avoid the blind spots of vehicles turning off. Reduce speed as a precaution when other road users turn right.

Injuries and death caused by riding incorrectly

A pedelec is not a bicycle. Incorrect riding and underestimated speeds soon result in hazardous situations. This may cause a fall with serious injuries or even death.

- ▶ If you haven't ridden on a pedelec for some time, get accustomed to the speed first before you ride at speeds over 12 km/h. Increase the level of assistance gradually.
- ▶ Practice braking hard on a regular basis.
- ▶ Take and complete a riding safety course.



CAUTION

Crash caused by loose clothing

Shoe laces, scarves and other loose items may become entangled in the spokes on the *wheels* and on the *chain drive*. This may cause a crash with injuries.

- ▶ Wear sturdy footwear and close-fitting clothing.



CAUTION

Risk of fire and burning due to hot motor

The motor housing becomes hot when riding. Touching it may cause burns to the skin or other objects.

- ▶ Never touch the motor housing directly after riding.
- ▶ Never place the pedelec on a flammable surface, such as grass or wood, directly after use.

Crash caused by soiling

Heavy soiling can impair pedelec functions, such as braking. This may cause a crash with injuries.

- ▶ Remove coarse soiling before riding.

Crash caused by poor road conditions

Loose objects, such as branches and twigs, may become caught in the wheels and cause a crash with injuries.

- ▶ Be aware of the road conditions.

Ride slowly and brake in good time.

Notice

Heat or direct sunlight can cause the *tyre pressure* to increase above the permitted maximum pressure. This can destroy the *tyres*.

- ▶ Never park the pedelec in the sun.
- ▶ On hot days, regularly check the *tyre pressure* and adjust it as necessary.

When riding downhill, high speeds may be reached.

The pedelec is only designed to exceed a speed of 25 km/h for short intervals. The *tyres* in particular can fail if exposed to a continuous load.

- ▶ Use the brakes to decelerate the pedelec if you reach speeds greater than 25 km/h.

Notice

Moisture penetrating at low temperatures may impair individual functions due to the open structural design.

- ▶ Always keep the pedelec dry and free from frost.
- ▶ If the pedelec is to be used at temperatures below 3 °C, the specialist dealer must carry out an inspection and prepare it for winter use.

Off-road riding subjects the joints in the arms to severe strain.

- ▶ Take a break from riding every 30 to 90 minutes, depending on the road surface conditions

6.1.1 Tips for a greater range

How far can a pedelec actually travel? There is no simple answer to this question as range depends on many influencing factors. A single battery charge may only last fewer than 20 kilometres but much more than 100 is also possible. There are a few tips which will help you maximize the range.

Pedalling frequency

Pedalling frequencies higher than 50 revolutions per minute optimise drive unit efficiency. However, very slow pedalling uses up a great deal of energy.

Weight

Weight should be minimised. The total weight of the pedelec and baggage should not be unnecessarily high.

Stopping & starting

Stopping and starting all the time is less economical than long stretches at the same speed, just like with a car.

Gear shift

Shifting gears correctly increases efficiency. It is best to set off and ride up hills using a low gear and switch up a gear depending on the speed and terrain. The display screen provides gear shift recommendations.

Tyre pressure

Rolling resistance can be minimised if tyres are inflated to the right pressure. Tip: Use the maximum permitted tyre pressure to optimize your range.

Motor power indicator

Keep an eye on the motor power indicator on the display screen and adjust your riding accordingly. A long bar indicates high power consumption.

Battery & temperature

Battery performance is reduced as the temperature drops since this increases electrical resistance. As a result, you should expect the range to be shorter than normal in winter.

6.1.2 Personal protective equipment

We recommend that you wear a suitable cycling helmet. We also recommend that you wear sturdy footwear and typical, close-fitting, reflective cycling clothing.

6.2 Error messages

6.2.1 Error message display

Parts of the electronic drive system are permanently monitored during use and charging. If an error is detected, the error code detected appears on the display screen. Press any button on the control panel to switch the display screen back to the default screen.

Power assistance is automatically stopped in the case of specific error codes. There is no longer power assistance, but you can still use the pedelec in a conventional manner without the drive.

If an error is shown, correct it using the measures described in the following table and/or contact your specialist dealer.

| Symptom | Cause | Remedy |
|---|---|---|
| A torque sensor error is displayed on starting up. | Are you applying pressure to the pedals when switching on? | ▶ Press the On-Off button again and avoid applying pressure to the pedals. |
| The pedelec has only a little power assistance after starting up. | | |
| An error is displayed on starting up. | Are you pressing other buttons while pushing the On-Off button? | ▶ Press the On-Off button again and avoid pushing other buttons at the same time. |

Table 29: Error solution when switching on

6.3 Instruction and customer service

Your supplying specialist dealer will provide customer service. Contact details can be found on the pedelec pass for these operating instructions. If you are unable to contact your specialist dealer, you will find other specialist dealers online at www.hercules-bikes.de. The specialist dealer will explain all the pedelec functions to you in person, this being when the specialist dealer hands over the pedelec at the latest. These operating instructions are provided to you with every pedelec, so that you can consult them at a later stage.

Your specialist dealer will also be happy to assist you in the future whether you require maintenance, conversion or repair.

6.4 Adjusting the pedelec



CAUTION

Crash caused by incorrectly adjusted torques

If a screw is fastened too tightly, it may break. If a screw is not fastened enough, it may loosen. This will cause a crash with injuries.

- ▶ Always observe the indicated torques on the screw or in the *operating instructions*.

Only a correctly adjusted pedelec will guarantee the desired ride comfort and health-promoting activity. Therefore adjust the *saddle*, the *handlebars* and the *suspension* to your body and your preferred riding style before the first ride.

6.4.1 Adjusting the saddle

6.4.1.1 Adjusting the saddle tilt

The saddle tilt must be adjusted to the seat height, the saddle and handlebar position, and the saddle shape to ensure an optimum fit. The seating position can be optimised in this way if needed. First, readjust the saddle after finding the handlebar position you prefer.

- ▶ Place the saddle tilt in the horizontal position to adjust the pedelec to your needs for initial use.

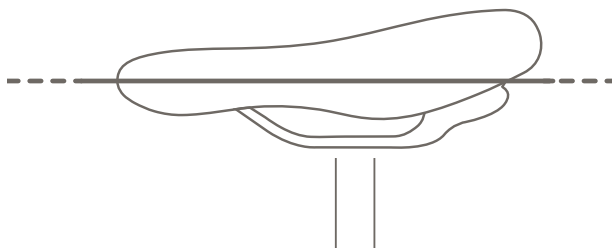

Figure 46: Horizontal saddle tilt

6.4.1.2 Determining the seat height

- ✓ To determine the seat height safely, either push the pedelec near to a wall, so that you can lean on the wall to support yourself or ask another person to hold the pedelec for you.

- 1 Climb onto the bicycle.
 - 2 Place your heel on the pedal and extend your leg, so that the pedal is at the lowest crank rotation point.
- ⇒ The rider sits straight on the saddle if the seat is at an optimum height. If this is not the case, you can adjust the length of the seat post to your needs.

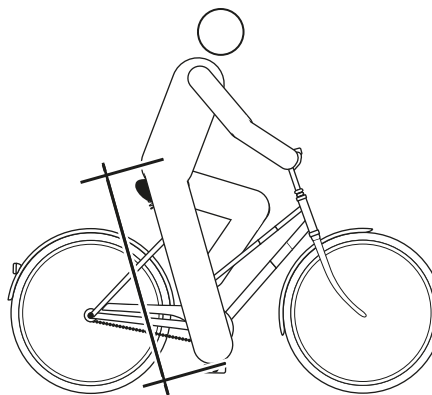

Figure 47: Optimal saddle height

6.4.1.3 Adjusting the seat height with quick release

- 1 Open the quick release on the seat post (1) to change the seat height. To do so, push the clamping lever away from the seat post (3).

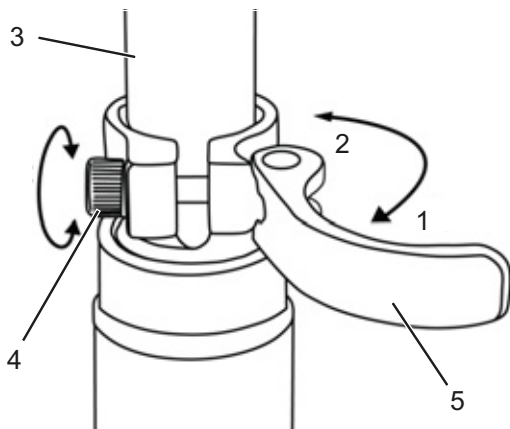

Figure 48: Opening the seat post quick release

- 2 Set the seat post at the required height.



Crash caused by an excessively high seat post setting

A seat post with is set too high will cause the seat post or the frame to break. This will cause a crash with injuries.

- ▶ Do not pull the seat post out of the frame beyond the minimum insertion depth marking.

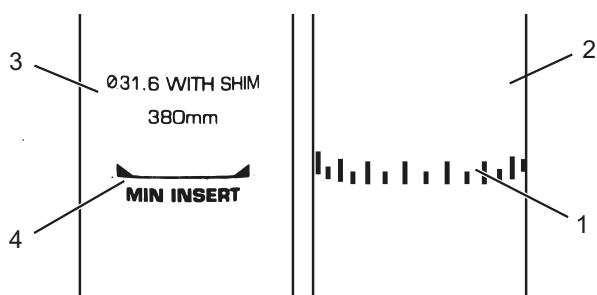

Figure 49: Detailed view of the seat post – examples of the minimum insertion depth marking

- 3 To close it, push the seat post clamping lever as far as it will go into the seat post (2).
- 4 Check the clamping force of quick releases.

6.4.1.4 Height-adjustable seat post

Only applies to pedelecs with this equipment

Preparing

- 1 When using your seat post for the first time, you must give it a firm push downwards to set it in motion. This is due to the natural tendency of the seal to repel oil from the seal surface. You only need to do this before the first use or after a longer period of non-use.

⇒ Once you have displaced the post through its deflection, the oil spreads on the seal and the post begins to function normally.

Lowering the saddle

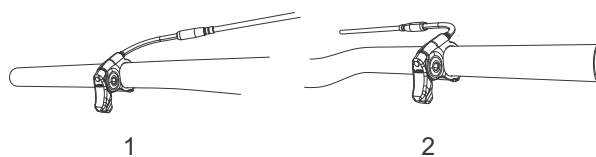

Figure 50: The seat post lever can be installed either on the left (1) or right (2) side of the handlebars

- 1 Press your hand down on the saddle or sit on the saddle to lower the saddle.
- 2 Press the seat post lever and hold it down.
- 3 Release the seat post lever once you have reached the required height.

Raising the saddle

- 1 Press the seat post lever and hold it down.
- 2 Remove any pressure from the saddle.
- 3 Release the seat post lever once you have reached the required height.

6.4.1.5 Adjusting the seat position

The saddle can be shifted on the saddle frame. The right horizontal position ensures an optimal leverage position for legs. This prevents knee pain and painful incorrect pelvis positions. If you have displaced the saddle more than 10 mm, you need to adjust the saddle height again since both settings affect one another.

- ✓ To adjust the seat position safely, either push the pedelec near to a wall, so that you can lean on the wall to support yourself or ask another person to hold the pedelec for you.

- 1 Climb onto the bicycle.
- 2 Place the pedals into the vertical position with your feet.



The rider is sitting in the optimal sitting position if the knee cap perpendicular line runs through the pedal axle.

- 3.1 If the perpendicular line crosses behind the pedal, bring the saddle forward.
- 3.2 If the perpendicular line crosses in front of the pedal, bring the saddle back.
- 4 Move the saddle within its permitted displacement range only (marked on the saddle stay).

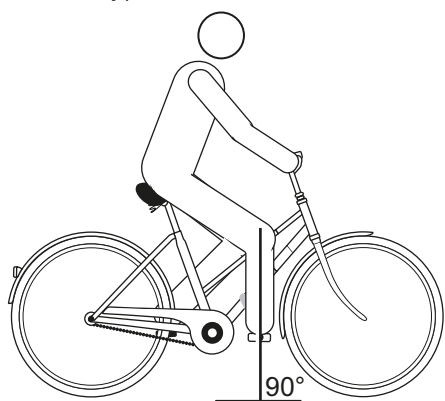

Figure 51: Knee cap perpendicular line

- ✓ The handlebar settings must only be adjusted while the pedelec is stationary.
- ▶ Unfasten and adjust the designated screw connections, and clamp them with the maximum tightening torque for the clamping screws of the handlebars.

6.4.2 Adjusting the handlebars



Crash caused by incorrectly set clamping force

Excessively high clamping force will damage the quick release and cause it to lose its function. Insufficient clamping force will cause a detrimental transmission of force. This can cause components to break. This will cause a crash with injuries.

- ▶ Never fasten a quick release using a tool (e.g. hammer or pliers).
- ▶ Only use the clamping lever with the specified set clamping force.

6.4.2.1 Adjusting the stem



Crash caused by loose stem

Incorrectly fastened screws may come loose due to impact. The stem may no longer be firmly fixed in its position as a result. This will cause a crash with injuries.

- ▶ Check the handlebars and the quick release system are firmly in position after the first two hours of riding.

6.4.2.2 Adjusting the height of the handlebars

- 1 Open the stem clamping lever.

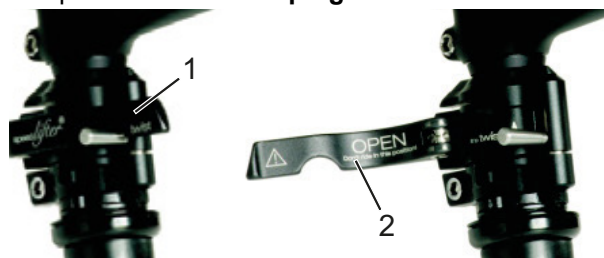

Figure 52: Open (2) and closed (1) stem clamping lever; by.schulz speedlifter used as an example

- 2 Pull the locking lever on the stem up, and simultaneously pivot the handlebars into the desired position.

⇒ You feel the locking lever click into place.

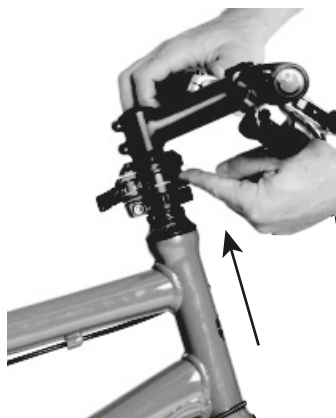

Figure 53: Pulling locking lever upwards – by.schulz speedlifter used as an example

3 Pull out the handlebars to the required height.

4 Close the **stem clamping lever**.

6.4.2.3 Adjusting the quick release clamping force

- ▶ If the *clamping lever on the handlebars* cannot be moved into its final position, unscrew the *knurled nut*.
- ▶ Tighten the *knurled nut* on the seat post if the *seat post clamping lever's* clamping force is not sufficient.
- ▶ If you are unable to set the clamping force, the specialist dealer will need to check the quick release.

6.4.3 Adjusting the brake lever

6.4.3.1 Adjusting the pressure point on a Magura brake lever

WARNING

Brake failure due to incorrect setting

If the pressure point is set with brakes where the brake linings and brake disc have reached their wear limit, the brakes may fail and cause an accident with injury.

- ▶ Before you set the pressure point, ensure that the brake linings and brake disc have not reached their wear limit.

The pressure point setting is adjusted using the twist knob.

- ▶ Turn the twist knob towards the plus (+) symbol.
- ⇒ The *brake lever* moves closer to the handlebar grip. Re-adjust the grip distance as necessary.
- ⇒ The lever pressure point activates sooner.

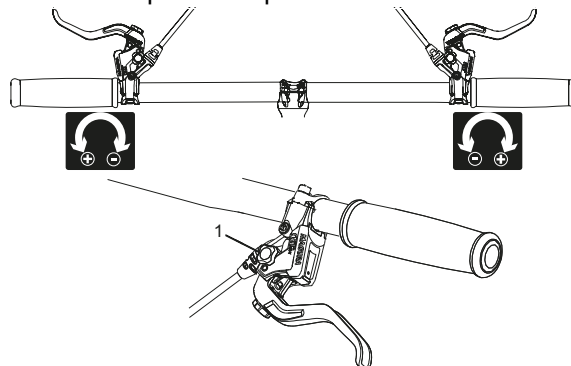

Figure 54: Using the twist knob (1) to adjust the pressure point

6.4.3.2 Adjusting the grip distance

WARNING

Crash caused by incorrectly set grip distance

If brake cylinders are set incorrectly or installed wrongly, the braking power may be lost at any time. This may cause a crash with injuries.

- ▶ Once the grip distance has been set, check the position of the brake cylinder and adjust it as necessary.

Never correct the brake cylinder position without special tools. Have a specialist dealer correct it.

- ▶ The brake lever grip distance can be adjusted to ensure that it can be reached more easily. Contact your specialist dealer if the brake handle is too far from the handlebars or is hard to use.

6.4.3.3 Adjusting the grip distance on a Magura brake lever

Only applies to pedelecs with this equipment

Use a T25 TORX® wrench to turn the setting screw to adjust the grip distance.

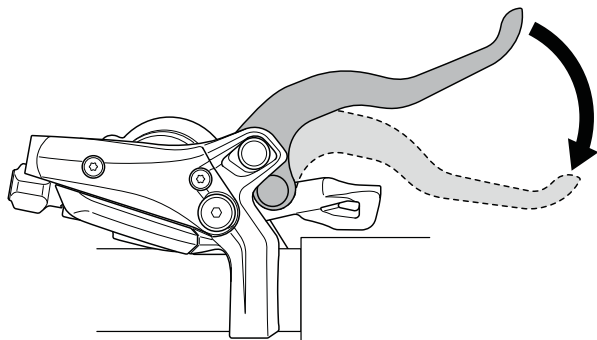

Brake lever grip distance

- ▶ Turn the setting screw in the minus (-) direction.
 - ⇒ The brake lever moves closer to the handlebar grip.
- ▶ Turn the setting screw in the plus (+) direction.
 - ⇒ The brake lever moves away from the handlebar grip.

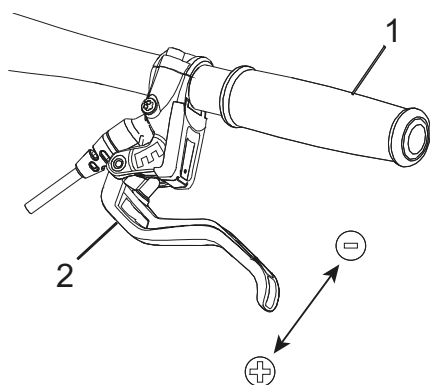

Figure 55: Using the setting screw (2) to adjust the distance from the brake lever to the handlebar grip (1)

6.4.4 Adjusting Suntour fork

Only applies to pedelecs with this equipment



Crash caused by incorrectly set suspension

If the suspension is adjusted incorrectly, the fork may become damaged, so that problems may occur when steering. This will cause a crash with injuries.

- ▶ Never ride the pedelec without air in the air suspension fork.
- ▶ Never use the pedelec without adjusting the suspension fork to the rider's weight.

Notice

Settings on the chassis change riding performance significantly. You need to get used to the pedelec and break it in to prevent accidents.

The adjustment shown here represents a basic setting. The rider should change the basic setting to suit the surface and his/her preferences.

- ▶ It is advisable to make a note of the basic setting. This way, it can be used as the starting point for subsequent, optimised settings and to safeguard against unintentional changes.

6.4.4.1 Adjusting the negative deflection

Negative deflection depends on the rider's weight and sitting position. The recommended negative deflection is between 15% (hard) and 30% (soft) of the *total fork deflection*.

6.4.4.2 Adjusting the steel suspension fork negative deflection

Only applies to pedelecs with this equipment

You can adjust the tensioning in the fork spring to the rider's weight and their preferred riding style. This reduces the negative deflection in the fork.



Figure 56: Negative deflection setting wheel on the suspension fork crown

- 1 You will find the **negative deflection setting wheel** beneath the plastic cover on the **crown**. Remove the plastic cover. Turn the **negative deflection setting wheel** in a clockwise direction to increase the spring pre-tensioning. Turn the **negative deflection setting wheel** in an anti-clockwise direction to decrease the spring pre-tensioning.

⇒ You will have made the ideal setting when the shock absorber deflects 3 mm when subject to the rider's weight.

- 3 Replace the plastic cover on the **crown** after making the setting.

6.4.4.3 Adjusting the air suspension fork negative deflection

Only applies to pedelecs with this equipment

- The **air valve** is located beneath the **valve cap** on the **crown** of the left-hand shock absorber. Unscrew the **valve cap**.



Figure 57: Screw caps in different designs

- 1 Attach a high pressure damper pump to the **air valve**.
- 2 Pump air suspension fork to the required pressure. Observe the levels in the **Suntour filling pressure table**. Never exceed the recommended **maximum air pressure**.

| Rider weight | AION, NEX | XCR 32, XCR 34 |
|-----------------------------|----------------|----------------|
| < 55 kg | 35 - 50 psi | 40 - 55 psi |
| 55 - 65 kg | 50 - 60 psi | 55 - 65 psi |
| 65 - 75 g | 60 - 70 psi | 65 - 75 psi |
| 75 - 85 kg | 70 - 85 psi | 75 - 85 psi |
| 85 - 95 kg | 85 - 100 psi | 85 - 95 psi |
| < 100 kg | + 105 psi | + 100 psi |
| Maximum air pressure | 150 psi | 180 psi |

Table 30: Suntour filling pressure table for air forks

- 3 Detach high-pressure damper pump.
- 4 Measure the distance between the **crown** and the **dust seal**. This distance is *total deflection* of the fork.
- 5 Push a temporarily attached cable tie downward against the **dust seal**.
- 6 Put on your normal cycling clothing, including luggage.
- 7 Sit on the pedelec in your usual riding position and support yourself against an object, such as a wall or tree.
- 8 Get off the pedelec without allowing it to deflect.
- 9 Measure distance between the **dust seal** and the cable tie.
 - ⇒ This measurement is the negative deflection. The recommended value is between 15% (hard) and 30% (soft) of the total fork deflection.
- 10 Increase or reduce air pressure until you have reached the desired negative deflection.
 - ⇒ If the negative deflection is correct, turn the **valve cap** in a clockwise direction.
 - ⇒ If you are unable to achieve the desired negative deflection, an internal adjustment may be needed. Contact your specialist dealer.

6.4.4.4 Adjusting the air suspension fork rebound

Only applies to pedelecs with this equipment

The *rebound* setting depends on the *negative deflection* setting: A higher negative deflection requires a lower rebound setting.

- 1 Turn the **Suntour rebound screw** in a clockwise direction to the closed position until it stops.

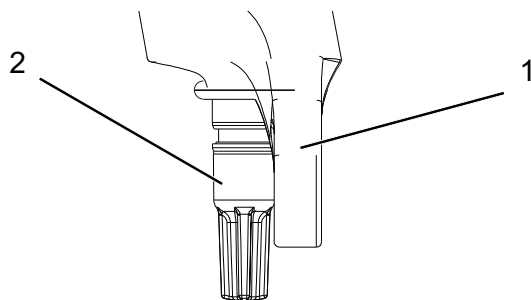

Figure 58: Suntour rebound screw (2), fork (1)

- 2 Turn the **Suntour rebound screw** slightly in an anti-clockwise direction.
- 3 Adjust the rebound in such a way that the fork rebounds quickly, but without bottoming out upward. Bottoming out refers to when the fork rebounds too quickly and stops moving abruptly once it has reached the full rebound distance. You can hear and feel a slight impact when this happens.

6.4.5 Adjusting the FOX fork

Only applies to pedelecs with this equipment



Crash caused by incorrectly set suspension

If the suspension is adjusted incorrectly, the fork may become damaged, so that problems may occur when steering. This will cause a crash with injuries.

- ▶ Never ride the pedelec without air in the air suspension fork.
- ▶ Never use the pedelec without adjusting the suspension fork to the rider's weight.

Notice

Settings on the chassis change riding performance significantly. You need to get used to the pedelec and break it in to prevent accidents.

It is recommended to note down the determined negative deflection and rebound levels. This way, the levels can be used as a starting point for subsequent, optimised settings and as a safeguard against unintentional changes.

The adjustment shown here represents a basic setting. The basic setting can be adjusted to the riding surface and personal preferences.

6.4.5.1 Adjusting the negative deflection

Negative deflection depends on the rider's weight and sitting position. The recommended negative deflection is between 15% (hard) and 20% (soft) of the *total fork deflection* depending on preferences and pedelec use.

- ✓ When adjusting the negative deflection, ensure that each pressure level adjuster is in an open position, i.e. each pressure level adjuster has been turned in an anti-clockwise direction until it goes no further.
- ✓ The pressure is to be measured at an ambient temperature of 21 to 24 °C.

- 1 The **air valve** is located beneath a blue **valve cap** on the **crown** of the left-hand shock absorber. Unscrew the **valve cap** in an anti-clockwise direction.
- 2 Attach a high pressure damper pump to the **air valve**.
- 3 Pump the suspension fork to the required pressure. Observe the levels in the **FOX filling pressure table**. Never exceed the **maximum air pressure** or fall below the **minimum air pressure** recommended in the table.

| Rider weight | Rhythm 34 | Rhythm 36 |
|-----------------------------|--------------------------|--------------------------|
| Minimum air pressure | 40 psi (2.8 bar) | 40 psi (2.8 bar) |
| 54 - 59 kg | 58 psi | 55 psi |
| 59 - 64 kg | 63 psi | 59 psi |
| 64 - 68 kg | 68 psi | 63 psi |
| 68 - 73 kg | 72 psi | 67 psi |
| 73 - 77 kg | 77 psi | 72 psi |
| 77 - 82 kg | 82 psi | 76 psi |
| 82 - 86 kg | 86 psi | 80 psi |
| 86 - 91 kg | 91 psi | 85 psi |
| 91 - 95 kg | 96 psi | 89 psi |
| 95 - 100 kg | 100 psi | 93 psi |
| 100 - 104 kg | 105 psi | 97 psi |
| 104 - 109 kg | 110 psi | 102 psi |
| 109 - 113 kg | 114 psi | 106 psi |
| Maximum air pressure | 120 psi (8.3 bar) | 120 psi (8.3 bar) |

Table 31: FOX filling pressure table for air fork

- 4 Detach high-pressure damper pump.
 - 5 Measure the distance between the crown and the fork's dust wiper. This distance is *total deflection* of the fork.
 - 6 Push the O-ring downwards against the fork's dust wiper. If there is no O-ring, attach a cable tie to the stanchion temporarily.
 - 7 Put on your normal cycling clothing, including luggage.
 - 8 Sit on the pedelec in your usual riding position and support yourself against an object, such as a wall or tree.
 - 9 Get off the pedelec without the suspension fork deflecting.
 - 10 Measure the distance between the dust wiper and the O-ring or cable tie.
- ⇒ This measurement is the negative deflection. The recommended value is between 15% (hard) and 20% (soft) of the *total fork deflection*.

11 Increase or reduce the air pressure until you have reached the desired negative deflection.

⇒ If the negative deflection is correct, turn the blue **valve cap** in a clockwise direction.

If you are unable to achieve the desired negative deflection, internal settings may need to be changed. Contact your specialist dealer.



6.4.5.2 Adjusting the rebound

The rebound defines the speed at which the fork rebounds after being loaded. The rebound setting depends on the air pressure setting. A higher *negative deflection* requires a lower rebound setting.

- 1 Turn the **FOX rebound adjuster** in a clockwise direction to the closed position until it stops.



Figure 59: FOX rebound adjuster (1) on the fork end

- 2 Turn the **FOX rebound adjuster** slightly in an anti-clockwise direction.
- 3 Adjust the rebound in such a way that the fork rebounds quickly, but without bottoming out upward. Bottoming out refers to when the fork rebounds too quickly and stops moving abruptly once it has reached the full rebound distance. You can hear and feel a slight impact when this happens.

6.4.6 Setting the Suntour rear frame damper

Only applies to pedelecs with this equipment

6.4.6.1 Adjusting the negative deflection

Notice

If the air pressure in the rear frame damper is exceeded or undershot, the damper can be permanently damaged.

Do not exceed the maximum air pressure of 300 psi (20 bar).

Negative deflection depends on the rider's weight and sitting position. The recommended negative deflection should be between 25% and 30% of the *total rear frame damper deflection*, depending on preferences and pedelec use.

- ✓ When adjusting the negative deflection, ensure that the pressure level adjuster is in an open position, i.e. the **lockout lever** is in the OPEN position.
- 1 Remove the valve cap from the **air valve**.
 - 2 Attach a high-pressure damper pump.
 - 3 Adjust the rear frame damper air pressure to the rider's weight.
 - 4 Detach high-pressure damper pump.
 - 5 Measure the distance between the air chamber seal and the end of the rear frame damper. This gap is the *total rear frame damper deflection*.
 - 6 Put on your normal cycling clothing, including luggage.
 - 7 Sit on the pedelec in your usual riding position and support yourself against an object, such as a wall or tree.
 - 8 Push the O-ring downwards against the air chamber seal.
 - 9 Get off the pedelec without the suspension fork deflecting.
- ⇒ Measure the distance between the air chamber seal and the O-ring. This measurement is the negative deflection. The recommended value is between 25% (hard) and 30% (soft) of the *total rear frame damper deflection*.

- 10 Increase or reduce the air pressure until you have reached the desired negative deflection.

- ▶ If the negative deflection is correct, fasten the **valve cap** onto the valve.

6.4.6.2 Adjusting the rebound

The rebound defines the speed at which the rear frame damper rebounds after being loaded. The rebound setting depends on the air pressure setting. Higher sag settings require lower rebound settings.



Figure 60: Suntour rebound adjuster wheel (1) on the rear frame damper

- ▶ Turn the rebound adjuster wheel in the – direction to increase rebounding.
- ▶ Turn the rebound adjuster wheel in the + direction to reduce compressive deflection movements.

6.4.6.3 Setting the compression

You can use the pressure damper setting to adjust the rear frame damper to the ground conditions. The pressure damper setting defines the speed at which the rear frame damper rebounds after being subjected to load or impact.

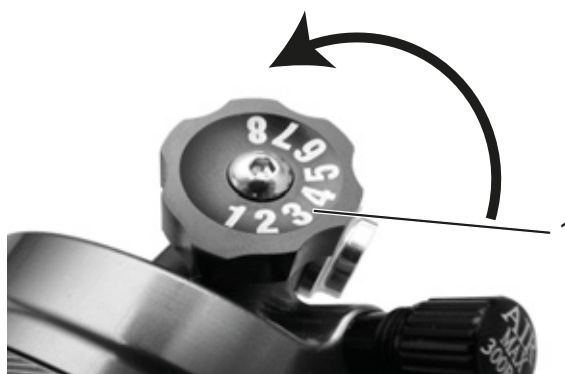

Figure 61: Suntour pressure level adjuster on the rear frame damper

- ▶ Turn the pressure level adjuster towards the – symbol to increase rebounding.
- ▶ Turn the pressure level adjuster towards the + symbol to reduce compressive deflection movement.

6.4.7 Setting the FOX rear frame damper

Only applies to pedelecs with this equipment

6.4.7.1 Adjusting the negative deflection

Notice

If the air pressure in the rear frame damper is exceeded or undershot, the damper can be permanently damaged.

Do not exceed the maximum air pressure of 350 psi (24.1 bar). The minimum air suspension pressure of 50 psi (3.4 bar) must be complied with.

⇒ *Negative deflection* depends on the rider's weight and sitting position. The recommended value is between 25% (hard) and 30% (soft) of the *total rear frame damper deflection*.

- 1 Turn the pressure level adjuster to the OPEN position.
- 2 Attach a high-pressure damper pump to the air valve.
- 3 Adjust the rear frame damper air pressure to the rider's weight.
- 4 Slowly compress the damper to over 25% of the deflection 10 times until you have reached the desired pressure.

⇒ This equalises the air pressure between the positive and negative air chambers. The high-pressure damper pump pressure gauge changes.

- 5 Remove the high-pressure damper pump.

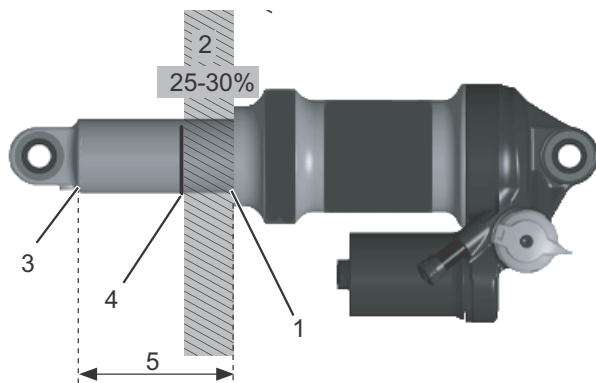

Figure 62: FOX rear frame damper

- 6 Measure the distance between the air chamber seal (1) and the end of rear frame damper (3). This gap is the *total deflection* for the rear frame damper (5).
- 7 Sit on the pedelec in your usual riding position and support yourself against an object, such as a wall or tree.
- 8 Push the O-ring (4) downwards against the air chamber seal (1).
- 9 Get off the pedelec without the suspension fork deflecting.
 - ⇒ Measure the distance between the air chamber seal (1) and the O-ring (4). This measurement is the *negative deflection* (2). The recommended value is between 25% (hard) and 30% (soft) of the *total deflection* for the rear frame damper (5).
- 10 Increase or reduce the air pressure until you have reached the desired negative deflection.

6.4.7.2 Adjusting the rebound

The rebound adjuster defines the speed at which the rear frame damper rebounds after being subjected to load or impact. The rebound setting depends on the air pressure setting. A higher negative deflection requires a lower rebound setting.

- 1 Attach a high-pressure damper pump to the air valve.
- 2 Read the air pressure.
- 3 Remove the high-pressure damper pump.

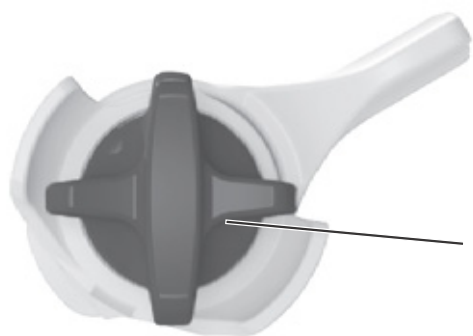

Figure 63: FOX rebound adjuster wheel (1) on the rear frame damper

- 4 Turn the rebound adjuster clockwise to the closed position until it stops.

- 5 Adjust the rebound setting based on the air pressure reading. Turn the rebound adjuster back anti-clockwise by the number of clicks specified in the table below.

| Air pressure (psi) | Recommended rebound setting |
|--------------------|-----------------------------|
| < 100 | Open (anti-clockwise) |
| 100 - 120 | 11 |
| 120 - 140 | 10 |
| 140 - 160 | 9 |
| 160 - 180 | 8 |
| 180 - 200 | 7 |
| 200 - 220 | 6 |
| 220 - 240 | 5 |
| 240 - 260 | 4 |
| 260 - 280 | 3 |
| 280 - 300 | 2 |

Table 32: Filling pressure table for the FOX air fork

6.4.8 Retracting the brake linings

Disc brakes require wearing-in time. The braking force increases over time. You therefore need to be aware that the braking force may increase during the wearing-in period. The same happens after brake pads or discs are replaced.

- ▶ Accelerate pedelec to about 25 km/h.
 - ▶ Brake pedelec until it comes to a halt.
 - ▶ Repeat process 30–50 times.
- ⇒ The brake disk is retracted and provides optimal braking power.

6.5 Accessories

We recommend a parking stand into which either the front wheel or rear wheel can be inserted securely for pedelecs which do not have a kickstand. The following accessories are recommended:

| Description | Article number |
|--|----------------|
| Protective cover for electrical components | 080-41000 ff |
| Panniers, system component* | 080-40946 |
| Rear wheel basket system component* | 051-20603 |
| Bicycle box system component* | 080-40947 |
| Parking stand universal stand | XX-TWO14B |

Table 33: Accessories

*System components are matched to the pannier rack and provide sufficient stability due to special transmission of force.

**System components are matched to the drive system.

6.5.1 Child seat

WARNING

Crash caused by incorrect child seat

The pannier rack and down tube are unsuitable for mounting child seats and may break. Such an incorrect position may cause a crash with serious injuries for the rider and the child.

- ▶ Never attach a child seat to the saddle, handlebars or down tube.

CAUTION

Crash caused by improper handling

When using child seats, the pedelec's handling characteristics and stability change considerably. This can cause a loss of control, a crash and injuries.

- ▶ You should practice how to use the child seat safely before using the pedelec in public spaces.

CAUTION

Risk of crushing due to exposed springs

The child may crush his/her fingers on exposed springs or open mechanical parts of the saddle or the seat post.

- ▶ Never install saddles with exposed springs if a child seat is being used.
- ▶ Never install seat posts with suspension with open mechanical parts or exposed springs if a child seat is being used.

Notice

- ▶ Observe the legal regulations on the use of child seats.
- ▶ Observe the operating and safety instructions for the child seat system.
- ▶ Never exceed the maximum permitted total weight.

The specialist dealer will advise you on choosing a suitable child seat system for the child and the pedelec.

The specialist dealer must install the child seat the first time to ensure that it is safely fitted.

When installing a child seat, the specialist dealer makes sure that the seat and the fastening mechanism for the seat are suitable for the pedelec and that all components are installed and firmly fastened. They will also ensure that shift cables, brake cables, hydraulic and electrical cables are adjusted as necessary, the rider's freedom of movement is not restricted maximum permitted total weight is not exceeded.

The specialist dealer will provide instruction on how to handle the pedelec and the child seat.

6.5.2 Bicycle trailers



Crash caused by brake failure

The brake may not work sufficiently if there is an excessive trailer load. The long braking distance can cause a crash or an accident and injuries.

- ▶ Never exceed the specified trailer load.

Notice

- ▶ The operating and safety instructions for the trailer system must be observed.
- ▶ The statutory regulations on the use of bicycle trailers must be observed.
- ▶ Only use type-approved coupling systems.

A pedelec which is approved for towing a trailer will bear an appropriate adhesive label. You may only use bicycle trailers with a support load and weight which do not exceed the permitted values.

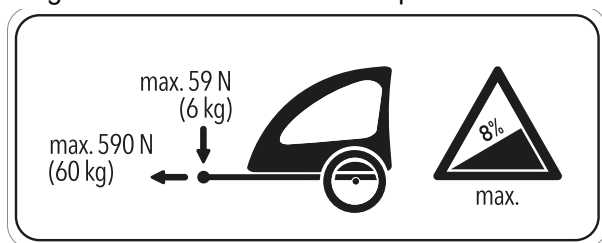

Figure 64: Trailer sign

The specialist dealer will advise on choosing a suitable trailer system for the pedelec. The specialist dealer must install the trailer the first time to ensure that it is safely fitted

6.5.3 Pannier rack

The specialist dealer will advise on choosing a suitable pannier rack.

The specialist dealer must install the pannier rack the first time to ensure that it is safely fitted.

When installing a pannier rack, the specialist dealer will make sure that the fastening mechanism for the rack is suitable for the pedelec and that all components are installed and firmly fastened. They will also ensure that shift cables, brake cables and hydraulic and electrical lines are adjusted as necessary, the rider's freedom of movement is not restricted and the maximum permitted total weight is not exceeded.

The specialist dealer will provide instruction on how to handle the pedelec and the pannier rack.

6.6 Before each ride



Crash caused by difficult-to-spot damage

If the pedelec topples over or you have a fall or an accident, there may be difficult-to-spot damage to components such as the brake system, quick releases or *frame*. This may cause a crash with injuries.

- ▶ Take the pedelec out of service and have a specialist dealer carry out an inspection.

Crash caused by material fatigue

Intensive use can cause material fatigue. A component may suddenly fail in case of material fatigue. This may cause a crash with injuries.

- ▶ Remove the pedelec from service immediately if there are any signs of material fatigue. Have the specialist dealer check the state.
- ▶ Have the specialist dealer carry out a basic inspection regularly. During the inspection, the specialist dealer will inspect the pedelec for any signs of material fatigue on the frame, fork, suspension element mountings (if there are any) and components made of composite materials.

Carbon becomes brittle when exposed to heat radiation such as heating. This can cause the carbon part to break and result in a crash with injuries.

- ▶ Never expose carbon parts on the pedelec to strong sources of heat.

6.7 Check list before each ride

- ▶ Check the pedelec before each ride.
- ⇒ Do not use the pedelec if there is evidently something wrong with it.

| | |
|--------------------------|--|
| <input type="checkbox"/> | Check that the pedelec is complete. |
| <input type="checkbox"/> | Check the battery is firmly in place. |
| <input type="checkbox"/> | Check that the lighting, reflector and brake, for instance, are sufficiently clean. |
| <input type="checkbox"/> | You must check that the mudguards, the pannier rack and the chain guard are securely installed. |
| <input type="checkbox"/> | Check that the front and rear wheels run true. This is particularly important if the pedelec been transported or secured with a lock. |
| <input type="checkbox"/> | Check the valves and the tyre pressure. Adjust as necessary before each ride. |
| <input type="checkbox"/> | If the pedelec has a hydraulic rim brake, check whether the locking levers are fully closed in their final positions. |
| <input type="checkbox"/> | Check the front and rear wheel brakes to make sure that they are working properly. To do so, push the brake levers while stationary to check whether resistance is generated in the usual brake lever position. The brake must not lose any brake fluid. |
| <input type="checkbox"/> | Check that the riding light is working. |
| <input type="checkbox"/> | Check for unusual noises, vibrations, smells, staining, deformation, cracks, scores, abrasion and wear. This indicates material fatigue. |
| <input type="checkbox"/> | Inspect suspension system for cracks, dents, bumps, parts or leaking oil. Look at concealed sections on the pedelec's lower surface. |
| <input type="checkbox"/> | Use body weight to compress suspension system. Adjust to the optimum sag value if suspension is too soft. |
| <input type="checkbox"/> | If quick releases are used check them to make sure that they are fully closed in their end position. If quick release axle systems are used, make sure that all attachment screws are tightened to the correct torque. |
| <input type="checkbox"/> | Be alert to any unusual operating sensations when braking, pedalling or steering. |
| <input type="checkbox"/> | Check that the ABS indicator lamp lights up correctly on pedelecs with an ABS system. |

6.8 Using the kickstand

CAUTION

Crash caused by a lowered kickstand

The kickstand does not fold up automatically. There is a risk of crashing if riding with the kickstand lowered.

- ▶ Raise the kickstand completely before setting off.

Notice

The pedelec's force of weight may cause the kickstand to sink into soft ground, possibly causing the pedelec to topple over as a result.

- ▶ The pedelec must be parked on firm, level ground only.
- ▶ It is particularly important to check that the pedelec is stable if it is equipped with accessories or loaded with baggage.

6.8.1 Raising the kickstand

- ▶ Before the ride, raise the kickstand completely with your foot.

6.8.1.1 Parking the pedelec

- ▶ Use your foot to lower the kickstand completely before parking.
- ▶ Park the pedelec carefully and check that it is stable.

6.9 Using the pannier rack

CAUTION

Crash caused by loaded pannier rack

The pedelec is handled differently with a loaded *pannier rack*, in particular when the rider needs to steer and brake. This can lead to a loss of control. This may cause a crash with injuries.

- ▶ You should practice how to use a loaded *pannier rack* safely before using the pedelec in public spaces.

CAUTION

Crash caused by unsecured baggage

Loose or unsecured objects on the *pannier rack*, e.g. belts, may become caught in the rear wheel. This may cause a crash with injuries.

Objects which are fastened to the pannier rack may cover the *reflectors* and the *riding light*. Other users may not see the pedelec on public roads as a result. This may cause a crash with injuries.

- ▶ Secure any objects which are attached to the *pannier rack* sufficiently.
- ▶ Objects fastened to the *pannier rack* must never cover the *reflectors*, the *headlight* or the *rear light*.

Crushing the fingers in the spring flap

The spring flap on the *pannier rack* operates with a high clamping force. There is a risk of crushing the fingers.

- ▶ Never allow the spring flap to snap shut in an uncontrolled manner.
- ▶ Be careful where you position your fingers when closing the spring flap.

Notice

The maximum load bearing capacity is indicated on the *pannier rack*.

- ▶ Never exceed the maximum permitted *total weight* when packing the pannier.
- ▶ Never exceed the maximum load bearing capacity of the pannier rack.
- ▶ Never modify the *pannier rack*.
- ▶ Distribute the baggage as evenly as possible between the left- and right-hand side.
- ▶ We recommend the use of panniers and baggage baskets.

6.10 Rechargeable battery

WARNING

Risk of fire and explosion due to faulty battery

The safety electronics may fail if the battery is damaged or faulty. The residual voltage can cause a short circuit. The battery may self-ignite and explode.

- ▶ Remove batteries with external damage from service immediately and never charge them.
- ▶ Only operate the battery and accessories if they are in perfect condition.
- ▶ Only use batteries which are approved for use on your e-bike.
- ▶ Do not use the battery with defective connecting cables or defective contacts.
- ▶ Use the battery with BMZ Systems e-bikes only. This is the only way that the battery will be protected from dangerous overloading.
- ▶ If the battery becomes deformed or begins to smoke, keep at a safe distance, disconnect the power supply at the socket, and notify the fire service immediately.
- ▶ Never extinguish a damaged battery with water or allow it to come into contact with water.
- ▶ If a battery is dropped or struck but shows no signs of external damage, remove it from service and observe it for at least 24 hours.
- ▶ Faulty batteries are hazardous goods. Dispose of faulty batteries properly and as quickly as possible.
- ▶ Store in a dry place until disposal. Never store in the vicinity of flammable substances.
- ▶ Never open or repair the battery.
- ▶ Charge the battery before use. Only use the charger included in the scope of delivery.
- ▶ Avoid wide temperature fluctuations.

WARNING

- ▶ Do not use the battery at altitudes higher than 2,000 m.

CAUTION

Chemical burns to the skin and eyes caused by faulty battery

Liquids and vapours may leak from a damaged or faulty battery. Excessive temperatures can also cause liquid to leak from the battery and the battery will become damaged. Such liquids can irritate the airways and cause burns.

- ▶ Avoid contact with leaked liquids.
- ▶ Immediately consult a doctor in case of contact with the eyes or any discomfort.
- ▶ In case of contact with the skin, rinse off immediately with water.
- ▶ Ventilate the room well.
- ▶ Protect the battery against heat over 60 °C, e.g. against permanent direct sunlight.

Risk of fire and explosion due to short circuit

Small metal objects may jumper the electrical connections of the battery. The battery may self-ignite and explode.

- ▶ Keep paper clips, screws, coins, keys and other small parts away and do not insert them into the battery.

Risk of fire and explosion due to penetration by water

The battery is only protected from simple spray water. Penetration by water can cause a short circuit. The battery may self-ignite and explode.

- ▶ Never immerse the battery in water.
- ▶ Never clean the battery with a pressure washer.
- ▶ If there is reason to believe that water may have entered into the battery, the battery must be removed from service.

Notice

If you leave a key inserted when riding or transporting the pedelec, it may break off or the locking system may open accidentally.

- ▶ Remove the key from the battery lock immediately after use.
- ▶ We recommend that you attach the key to a key ring.

- ✓ Switch off the battery and the drive system before removing or inserting the battery.

6.10.1 Removing the battery

- ▶ Use your right hand to push the battery up into the frame.
- ⇒ The lock hook is disengaged in the frame.
- ▶ Hold underneath the battery with your right hand. Press key towards the down tube.
- ⇒ The lock hook releases the battery.
- ▶ The battery will now fall out of the frame or can be pulled out of the down tube, depending on how much space there is between the battery and down tube.
- ▶ Remove the key from the lock.

6.10.2 Inserting the battery

- ▶ Place the battery into the lower mount with the contacts facing the front.
- ▶ Open the lock with the key.
- ▶ Press the key towards the down tube and hold.
- ⇒ The lock hook in the frame clears the way for the battery.
- ▶ Swivel the battery into the down tube. Apply a little pressure to push the battery into the frame.
- ▶ Release the key.
- ▶ The lock hook moves into the secure position and holds the battery.
- ▶ Close the lock. Remove the key.
- ▶ Check the battery is firmly in position.

6.10.3 Charging the battery



CAUTION

Fire caused by overheated charger

The charger heats up when charging the battery. In case of insufficient cooling, this can result in fire or burns to the hands.

- ▶ Never use the charger on a highly flammable surface (e.g. paper, carpet etc.).
- ▶ Never cover the charger during the charging process.
- ▶ Never leave a battery charging unattended.

Electric shock caused by penetration by water

If water penetrates into the charger, there is a risk of electric shock.

- ▶ Never charge the battery outdoors.

Electric shock in case of damage

Damaged chargers, cables and plug connectors increase the risk of electric shock.

- ▶ Check the charger, cable and plug connector before each use. Never use a damaged charger.

Risk of fire and explosion caused by damaged battery

The safety electronics may fail if the battery is damaged or faulty. The residual voltage can cause a short circuit. The battery may self-ignite and explode.

- ▶ If the battery becomes deformed or begins to smoke, keep at a safe distance, disconnect the power supply at the socket, and notify the fire service immediately.
- ▶ Never extinguish a damaged battery with water or allow it to come into contact with water.

Notice

▶ If an error occurs during the charging process, a system message is displayed. Remove the charger and battery from operation immediately and follow the instructions.

✓ The ambient temperature during the charging process must be within the range from 10 °C to 30 °C.

| | |
|----------------------|---------------|
| Charging temperature | 10 °C - 30 °C |
|----------------------|---------------|

✓ The battery can remain on the pedelec or can be removed for charging.

✓ Interrupting the charging process does not damage the battery.

▶ Remove the rubber cover from the battery.

▶ Connect the mains plug of the charger to a normal domestic, grounded socket.

| | |
|-----------------|--------------|
| Connection data | 230 V, 50 Hz |
|-----------------|--------------|

▶ Connect the charging cable to the battery's charging port. Only use the charger supplied in the scope of delivery.

⇒ The charging process starts automatically.

⇒ The battery level indicator indicates the charge level during charging. The charging process is complete when the LEDs on the battery level indicator go out.

6.10.4 Waking the battery

✓ When not used for a longer period, the battery switches to sleep mode for self-protection. The LEDs on the battery level indicator do not light up.

▶ Press the *On-Off button (battery)*.

▶ The battery level indicator shows the charge level.

6.11 Electric drive system

6.11.1 Switching on the electric drive system



Crash caused by lack of readiness for braking

When it is switched on, the drive system can be activated by the application of force on the pedals. There is a risk of a crash if the drive is activated unintentionally, and the brake is not reached.

- ▶ Never start the electric drive system, or switch it off immediately, if the brake cannot be reached safely and reliably.

Notice

- ▶ Do not apply any pressure to the pedelec's pedals when switching on the electric bicycle system. If you do, this may cause a torque sensor error or reduced assistance performance.
- ▶ Do not press any other buttons when pushing the On-Off button; if you do, an error will be displayed.

- ✓ A sufficiently charged battery has been inserted into the pedelec.
- ✓ The battery is firmly positioned.
- ▶ Press the **On-Off button (display)**.
 - ⇒ The indicator will switch on after a few seconds.
 - ⇒ If the drive system is switched on, the drive is activated as soon as the pedals are moved with sufficient force.

6.11.2 Switching off the drive system

Notice

- ▶ Never use the On-Off button while riding. When you don't need power assistance, press on the up or down button to select the level of assistance [NO ASSIST].

The system switches off automatically ten minutes after the last command.

- ▶ Press the **On-Off button (display)** while stationary to actively switch off the drive system.

6.12 Display

CAUTION

Crash caused by distraction

A lack of concentration while riding increases the risk of an accident. This may cause a crash with serious injuries.

- ▶ Never allow yourself to be distracted by the display.
- ▶ Stop pedelec if you want to make inputs on the display other than a change in level of assistance. Only enter data when the bicycle is stationary.

Notice

- ▶ Do not use the display as a handle. You may irreparably damage the display if you use it to lift the pedelec.
- ▶ If you do not use your pedelec for several weeks, remove the display from its mount. Store the display safely at room temperature in a dry environment.

6.12.1 Removing and attaching the display

Notice

If the rider is not present, the display can be used without authorisation, e.g. it may be stolen, the system settings may be changed or journey information may be read.

- ▶ Remove the display when the pedelec is parked.

The system is switched off by removing the display.

6.12.1.1 Attaching the display

- ▶ Align the display screen ▼ arrow and the mount ▲ arrow with one another.
- ▶ Slide the display in the direction of the arrow in the diagram until the display ▼ is pointing to the O position on the mount.

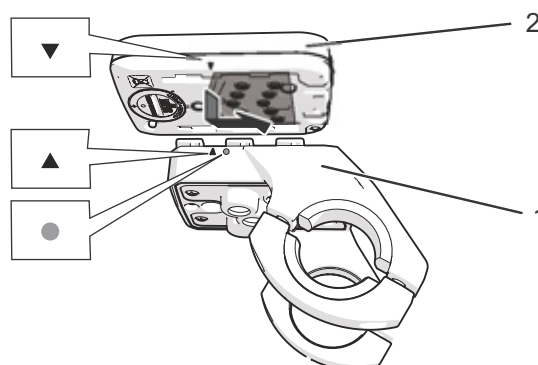

Figure 65: Attaching the display (2) to the mount (1)

- ▶ Press the On-Off button (display).
- ⇒ The LCD display lights up. The display is connected to the power.

6.12.2 Securing the display against removal

- ▶ Detach the mount from the handlebars.
- ▶ Insert the display in its mount.
- ▶ Use the setting screw (M4 x L10) to attach the display rear to the mount.

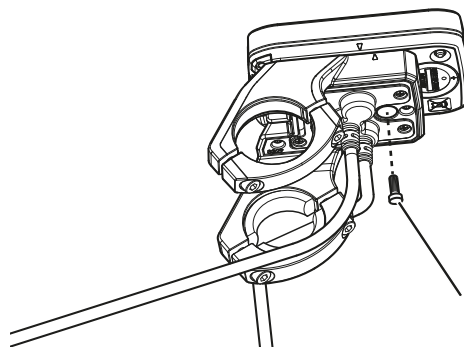

Figure 66: Using the setting screw (1) to fasten mount to display

- ▶ Fasten the mount to the handlebars.

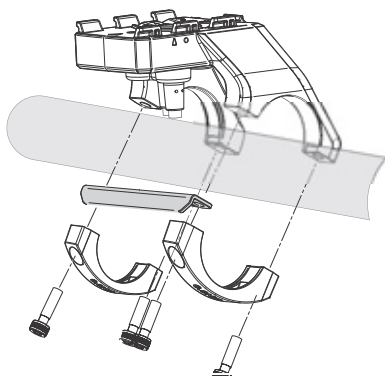

Figure 67: Screwing the mount to handlebars

6.12.2.1 Removing the display

Notice

- ▶ Never detach the display if it has been fastened to the mount with the setting screw.
- ▶ Never remove the display while riding.

Detach the indicator unit from the mount after you have switched off the electric bicycle system.

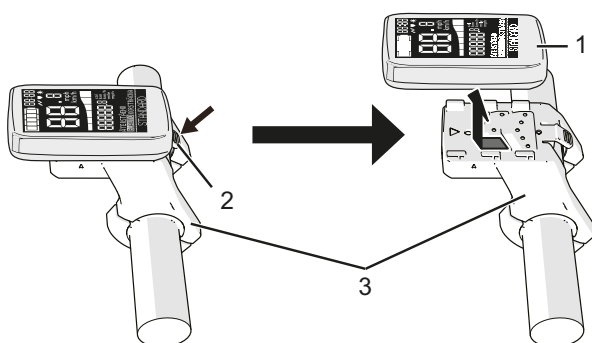

Figure 68: Pressing the catch (2) on the display (1) and removing from mount (3)

- ✓ The electric drive system is switched off.
- ▶ Slide the display forwards while pressing the mount catch bolt down at the same time.

6.12.3 Using the USB port

Notice

- ▶ Never recharge external devices while riding.

Any moisture which enters through the USB port may trigger a short circuit in the *display*.

- ▶ Regularly check the position of the rubber cover on the USB port and adjust it as necessary.

The device being charged may fall off, possibly causing a malfunction.

- ▶ Place the external device on a flat, stable surface only while it is charging.

Notice

The port function has only been tested with a few external devices and the exclusive USB cable. There is no guarantee that an external device will function correctly.

- ▶ Contact the external device manufacturer to find out whether it can be recharged with the Panasonic display.

- ▶ Back-up the internal data on the external device since there is a risk that they could be deleted.

- ▶ Do not connect the exclusive USB cable (optional) to any devices other than the control device. Devices could become damaged.

- ▶ Never recharge external devices in the rain. Never connect a damp or wet USB cable. The system may malfunction as a result.

You may recharge external devices such as mobile telephones, which can be connected to the control device via the USB cable. Connect the exclusive USB cable to recharge for more than three hours.

- ✓ External devices can only be recharged if the control device indicator unit and a charged battery are inserted into the pedelec.

- ▶ A USB cable compatible with the external device (available from retailers) is required.

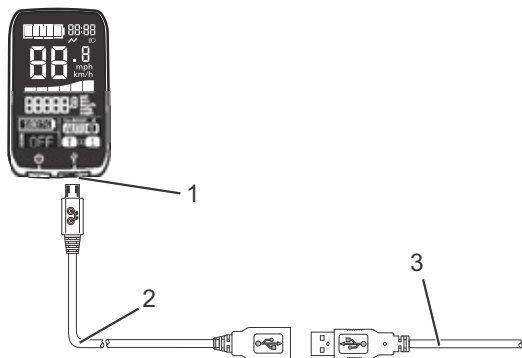

Figure 69: Pressing the catch (2) on the display (1) and removing from mount (3)

- ▶ Open the protective flap on the USB port.
- ▶ Connect the USB cable (optional; micro USB side: Type B; USB side: male) to the corresponding Micro-USB port on the control device indicator unit.
- ▶ Connect the USB cable (available from retailers) which is compatible with the external device to the external device and the exclusive USB cable (optional).
- ▶ Replace the protective flap after using the USB port.

6.12.4 Using the push assist system

Notice

The pedals turn when using the push assist due to the system design.

- ▶ You must steer the pedelec securely with both hands when using push assist.
- ▶ Allow for enough freedom of movement for the pedals.

The push assist helps the rider to push the pedelec. The speed can be a maximum of 6 km/h in this case.

- ▶ Hold down the *push assist button* to activate the push assist function.

Notice

- ▶ If the pedals strike against the kerb or another object and push assist stops working, hold down the push assist button (walk assist) again.
- ▶ Release the *push assist button* to deactivate the push assist function.

6.12.5 Using the riding light

- ✓ To switch on the *riding light*, the drive system needs to be switched on first.
- ▶ Press the *riding light button*.
- ⇒ The *riding light* is switched on (*riding light symbol* is displayed) or switched off (*riding light symbol* is not displayed).

6.12.6 Using night mode

Night mode changes the brightness of the indicator unit backlight. The backlight settings feature a normal mode and a night mode. Five brightness levels can be used in each mode.

Brightness is reduced in night mode compared to normal mode to ensure any glare is reduced while riding at night.

- ✓ The electric drive system is switched on.
- ▶ Press the **night mode button**.
- ⇒ The night mode indicator is displayed on the indicator unit and the backlight changes to night mode. Press the night mode button again to return to normal mode.

6.12.7 Selecting the level of assistance

- ✓ To switch on the level of assistance, the drive system has to be switched on already.
- ▶ Press the **up button** to increase the level of assistance.
- ▶ Press the **down button** to reduce the level of assistance.

6.12.8 Journey information

The displayed *journey information* can be changed and partially reset.

6.12.8.1 Changing the displayed journey information

The pedelec provides six types of journey information on the function display. The displayed journey information can be switched.

| Screen display | Function |
|------------------|---|
| TRIP | Distance travelled |
| AVG | Average speed |
| MAX | Maximum speed of a journey |
| ODO | Total distance travelled |
| RANGE | Expected range of the available battery charge, calculated based on the most recent riding mode (estimate). |
| BATTERY CAPACITY | Battery level as a percentage. |

Table 34: Journey information

| Screen display | Symbol with 2 indicators | Symbol with 4 indicators |
|----------------------------|--------------------------|--------------------------|
| TRIP | | |
| AVG | | |
| MAX | | |
| ODO | | |
| RANGE | | |
| REMAINING BATTERY CAPACITY | | |

Table 35: Journey information

- ▶ Press on the **info button** repeatedly until the required *journey information* is displayed.

6.12.8.2 Resetting the journey information

The journey information TRIP, AVG and MAX can be reset.

- ▶ Press the **info button** repeatedly until the required *journey information* is displayed.
 - ▶ Press the **info button** for a long time.
- ⇒ The value 0 is displayed.
- ⇒ The *journey information* TRIP, AVG or MAX is reset.

6.12.9 Changing the system settings

The *system settings* can be changed.

6.12.9.1 Changing the language

The language can be chosen from a selection of ten: English, German, Dutch, French, Italian, Spanish, Finnish, Swedish, Norwegian and Danish.

- ▶ Press the **info button** and the **down button** together for three seconds.
- ⇒ The *display screen* indicates LANGUAGE and the language currently selected.
- ▶ Press the **info button**.
- ⇒ The language currently selected starts to flash.
- ▶ Press the **up button** or **down button** repeatedly until the desired language is displayed.
- ▶ Press the **night mode button**.
- ⇒ The language has been changed.

6.12.9.2 Changing the display contrast

The contrast can be set in ten levels from level 1 to level 10.

- ▶ Press the **info button** and the **down button** together for three seconds.
- ▶ Press the **up button** or **down button** repeatedly until CONTRAST and the currently set value are shown on the *display screen*
- ▶ The value currently selected starts to flash.
- ▶ Press the **up button** or **down button** repeatedly until the desired Contrast is displayed.
- ▶ Press the **night mode button**.
- ⇒ The contrast has been changed.

6.12.9.3 Changing the brightness

The backlight settings feature a normal mode and a night mode. The backlight setting is changed depending on whether the light is switched on or off. The brightness can be set in five levels from OFF (no backlight) to level 4 (brightest level).

Set the normal mode brightness when the night mode indicator is not displayed. Set the night mode brightness when the night mode indicator is displayed.

If you set the same brightness for normal and night mode, the brightness will not change even if you switch modes.

- ▶ Press the **info button** and the **down button** together for three seconds.
 - ▶ Press the **up button** or **down button** repeatedly until BRIGHTNESS and the currently set value are shown on the *display screen*.
 - ▶ Press the **info button**.
 - ▶ The value currently selected starts to flash.
 - ▶ Press the **up button** or **down button** repeatedly until the desired brightness is displayed.
 - ▶ Press the **night mode button**.
- ⇒ The brightness has been changed.

6.12.9.4 Changing the unit of measure for speed

The unit of measure for speed can be set in km/h or mph.

- ▶ Press the **info button** and the **down button** together for three seconds.
 - ▶ Press the **up button** or **down button** repeatedly until UNIT and the currently set value are shown on the *display screen*.
 - ▶ Press the **info button**.
 - ▶ The value currently selected starts to flash.
 - ▶ Press the **up button** or **down button** repeatedly until the desired unit of measure is displayed.
 - ▶ Press the **night mode button**.
- ⇒ The brightness has been changed.

6.12.9.5 Setting information on the tyre size

- ▶ Press the **info button** and the **down button** together for three seconds.
 - ▶ Press the **up button** or **down button** repeatedly until WHEEL appears on the *display screen*.
 - ▶ Press the **info button**.
 - ▶ The value currently selected starts to flash.
 - ▶ Press the **up button** or **down button** repeatedly until the desired Size is displayed.
 - ▶ Press the **night mode button**.
- ⇒ The tyre size information has been changed.

6.12.9.6 Changing the distance travelled

- ▶ Press the **info button** and the **down button** together for three seconds.
 - ▶ Press the **up button** or **down button** repeatedly until ODO INPUT and the currently set value are shown on the *display screen*.
 - ▶ Press the **info button**.
 - ▶ The value currently selected starts to flash.
 - ▶ Press the **up button** or **down button** repeatedly until the desired distance travelled is displayed.
 - ▶ Press the **night mode button**.
- ⇒ The distance travelled has been changed.

6.12.9.7 Setting the clock

- ▶ Press the **info button** and the **down button** together for three seconds.
- ▶ Press the **up button** or **down button** repeatedly until **CLOCK** and the currently set time are shown on the *display screen*.
- ▶ Press the **info button**.
- ▶ The time currently selected starts to flash.
- ▶ Press the **info button**.
- ⇒ The time is displayed in 24-hour format. Pressing the button changes between hours and minutes.
- ▶ Press the **up button** or **down button** repeatedly until the desired time is displayed.
- ▶ Press the **night mode button**.
- ⇒ If the **night mode button** is pressed, the time will run starting from the changed time.

6.12.10 Replacing the battery

Notice

Battery fluid leaks can cause a malfunction on the display.

- ▶ Replace a used coin cell with a new one immediately in the display.
- ▶ Dispose of coin cells which can no longer be used in accordance with local recycling regulations.

The display features an integrated coin cell (3 V) for the time display memory. If the "0:00" time indicator flashes on the display screen, the coin cell has come to the end of its useful life. The clock functions are stopped if the coin cell has fully discharged.

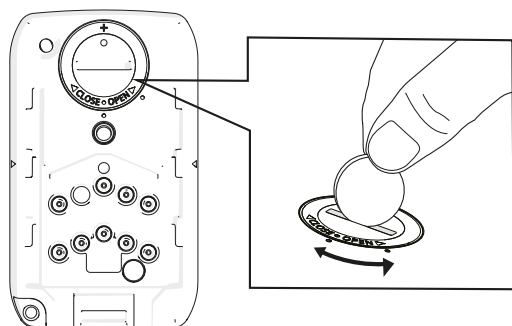

Figure 70: Open battery compartment with a coin on the display rear

- ▶ Use a coin to turn the battery compartment latching cover on the display rear in a anti-clockwise direction.
- ⇒ The coin cell compartment will open.
- ▶ Remove the coin cell.
- ▶ Remove the plastic shield from the minus pole side.
- ▶ Dispose of the plastic shield in the correct manner.
- ▶ Insert the coin cell into the battery compartment.
- ▶ Turn the latching cover clockwise. The battery compartment is now locked.

Notice

If the cover does not firmly latch into position, the indicator unit will not work properly since it will cause a malfunction caused by water penetrating the compartment, for example.

6.13 Brake

DANGER

Hydraulic fluid can be fatal if it is swallowed and penetrates into the respiratory system

Hydraulic fluid may leak out after an accident or due to material fatigue. Hydraulic fluid can be fatal if swallowed and inhaled.

First aid treatment

- ▶ Wear gloves and safety goggles as protective equipment. Keep unprotected persons away.
- ▶ Remove those affected from the danger area to fresh air. Never leave those affected unattended.
- ▶ Ensure sufficient ventilation.
- ▶ Immediately remove clothing items contaminated with hydraulic fluid.
- ▶ Serious slip hazard due to hydraulic fluid leakage.
- ▶ Keep away from naked flames, hot surfaces and sources of ignition.
- ▶ Avoid contact with skin and eyes.
- ▶ Do not inhale vapours or aerosols.

After inhalation

- ▶ Take in fresh air; consult doctor if any pain or discomfort.

After skin contact

- ▶ Wash affected skin with soap and water and rinse well. Remove contaminated clothing. Consult doctor if any pain or discomfort.

After contact with eyes

- ▶ Rinse eyes under flowing water for at least ten minutes with the lids open; also rinse under lids. Consult eye doctor if pain or discomfort continues.

DANGER

After swallowing

- ▶ Rinse out mouth with water. Never induce vomiting! Risk of aspiration!
- ▶ Place a person lying on their back who is vomiting in a stable recovery position on their side. Seek medical advice immediately.

Environmental protection measures

- ▶ Never allow hydraulic fluid to flow into the sewage system, surface water or groundwater.
- ▶ Notify the relevant authorities if fluid penetrates the ground or pollutes water bodies or the sewage system.

WARNING

Crash caused by brake failure

Oil or lubricant on the brake disc in a disc brake or on the rim of a rim brake can cause the brake to fail completely. This may cause a crash with serious injuries.

- ▶ Never allow oil or lubricant to come into contact with the brake disc or brake linings or on the rim of a rim brake.
- ▶ If the brake linings have come into contact with oil or lubricant, contact a dealer or a workshop to have the components cleaned or replaced.

If the brakes are applied continuously for a long time (e.g. while riding downhill for a long time), the fluid in the brake system may heat up. This may create a vapour bubble. This will cause air bubbles or any water contained in the brake system to expand. This may suddenly make the lever travel wider. This may cause a crash with serious injuries.

- ▶ Release the brake regularly when riding downhill for a longer period of time.

! WARNING**Amputation due to rotating brake disc**

The brake disc in disc brakes is so sharp that it can cause serious injuries to fingers if they are inserted into the brake disc openings.

Always keep fingers well away from the rotating brake disc.

! CAUTION**Crash caused by wet conditions**

The *tyres* may slip on wet roads. In wet conditions you must also expect a longer braking distance. The braking sensation differs from the usual sensation. This can cause loss of control or a crash, which may result in injuries.

- ▶ Ride slowly and brake in good time.

Crash caused by incorrect use

Handling the brake improperly can lead to loss of control or crashes, which may result in injuries.

- ▶ Shift your body weight backwards and down as far as possible.
- ▶ Practice braking and emergency braking before using the pedelec in public spaces.
- ▶ Never use the pedelec if you can feel no resistance when you grip the brake handle. Consult a specialist dealer.

Burns caused by heated brake

The brakes may become very hot during operation. There is a risk of burns or fire in case of contact.

- ▶ Never touch the components of the brake directly after the ride.

! CAUTION**Crash after cleaning or storage**

The brake system is not designed for use on a pedelec which is placed on its side or turned upside down. The brake may not function correctly as a result. This can cause a crash, which may result in injuries.

- ▶ If the pedelec is placed on its side or turned upside down, apply the brake a couple of times before setting off to ensure that it works as normal.
- ▶ Never use the pedelec if it no longer brakes as normal. Consult a specialist dealer.

The drive force of the motor is shut off during the ride as soon as the rider no longer pedals. The drive system does not switch off when braking.

- ▶ In order to achieve optimum braking results, do not pedal while braking.

6.13.1 Using the brake lever

Figure 71: Front (2) and rear (1) brake lever; Shimano brake used as an example

- ▶ Push the *left brake lever for the front wheel brake and the right lever for the rear wheel brake* until the desired speed is reached.

6.13.2 Using the back-pedal brake

Only applies to pedelecs with this equipment

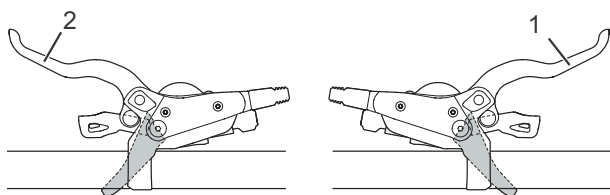
- ✓ The best braking effect is achieved if the pedals are in the 3 o'clock and 9 o'clock position when braking. To bridge the free travel between the riding movement and the braking movement, it is recommendable to pedal a little beyond the 3 o'clock and 9 o'clock position before you pedal in the opposite direction to the *direction of travel* and start braking.
- ▶ Pedal in the opposite direction to the *direction of travel* until the desired speed has been reached.

6.14 Suspension and damping

6.14.1 Adjusting the compression of the Fox fork

Only applies to pedelecs with this equipment

The compression adjuster makes it possible to make quick adjustments to the suspension behaviour of the fork to suit changes in terrain. It is intended for adjustments made during the ride.

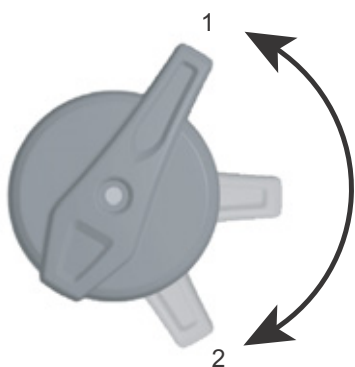

Figure 72: FOX compression adjuster with the OPEN (1) and HARD (2) positions

- ▶ Compression damping is lowest in the OPEN position, making the fork feel softer. Use the HARD position if you want the fork to feel stiffer and you are riding on soft ground. The lever positions between the OPEN and HARD positions enable fine adjustment of compression damping.

We recommend setting the lever of the compression adjuster to the OPEN mode position first.

6.14.2 Adjusting the compression of the Fox damper

Only applies to pedelecs with this equipment

The compression adjuster makes it possible to make quick adjustments to the suspension behaviour of the damper to suit changes in terrain. It is intended for adjustments made during the ride.



Figure 73: FOX compression adjuster on the rear frame damper with the OPEN (1), MEDIUM (2) and HARD (3) positions

- ▶ Use the OPEN position for rough descents, the MEDIUM position for rough terrain and the HARD position for efficient climbing. First set the compression adjuster to the OPEN position.

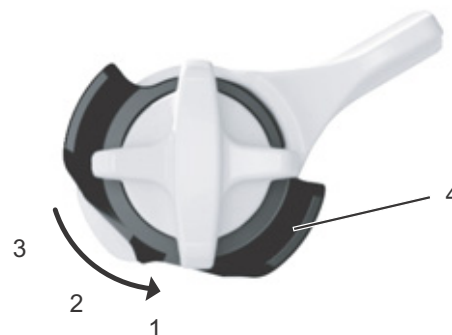

Figure 74: Fine adjustment of the OPEN position is made using the adjuster (4)

The FOX rear frame damper features fine adjustment for the OPEN position.

- ✓ We recommend that fine adjustments be made when the compression adjuster is in the MEDIUM or HARD position.
- ▶ Pull out the adjuster.
- ▶ Turn the adjuster to position 1, 2 or 3. Setting 1 is for the softest riding performance, whereas 3 is for the hardest.
- ▶ Press the adjuster in to lock in the setting.

6.14.3 Adjusting the compression of the Suntour fork

Only applies to pedelecs with this equipment

The compression adjuster makes it possible to make quick adjustments to the suspension behaviour of the fork to suit changes in terrain. It is intended for adjustments made during the ride.



Figure 75: Suntour compression adjuster with the OPEN (1) and LOCK (2) positions

- Compression damping is lowest in the OPEN position, making the fork feel softer. Use the LOCK position if you want the fork to feel stiffer and you are riding on soft ground. The lever positions between the OPEN and LOCK positions enable fine adjustment of compression damping.

We recommend setting the lever of the compression adjuster to the OPEN position first.

6.14.4 Adjusting the compression of a Suntour damper

Only applies to pedelecs with this equipment

The compression adjuster makes it possible to make quick adjustments to the suspension behaviour of the damper to suit changes in terrain. It should never be used while riding on rough terrain.



Figure 76: Suntour compression adjuster open (1)

- Use the OPEN position for rough descents and the LOCK position for efficient climbing. First set the compression adjuster to the OPEN position.



Figure 77: Suntour compression adjuster closed (2)

6.14.5 Adjusting the rebound in a Rock Shox damper

Only applies to pedelecs with this equipment

The rebound damper determines the speed at which the fork rebounds to full length after deflection. This speed affects the wheel's contact with the ground and thus has an influence on control and efficiency. The rear frame damper should rebound fast enough to sustain traction without producing an erratic or bumpy sensation. If rebound damping is too tight, the rear frame damper is unable to rebound fast enough before the next impact. The rebound damper for the rear wheel is located in the rear frame damper.



Figure 78: Setting the rebound damper strength on the rear frame damper setting wheel (1)

- Turn the setting wheel to the middle position.
- Ride the vehicle over a small obstacle.
- ⇒ The ideal setting for the rebound damper has been achieved when the rebound movement of the rear wheel feels comparable to that of the front wheel.

- ▶ If the rear wheel bounces back much more quickly or slowly than the front wheel, change the setting by turning the setting wheel.
- Turn the setting wheel in an anti-clockwise direction to increase the rebound speed.
- Turn the setting wheel in a clockwise direction to decrease the rebound speed.

6.14.6 Adjusting the compression in a Rock Shox damper

Only applies to pedelecs with this equipment

The compression damper controls the speed at which the rear frame damper deflects during slow impact, such as smaller impacts or when the rider goes round a corner or shifts their weight. The damper improves control and efficiency.

If the compression damper is set too high, the suspension is too hard during impacts. The lever is used to set the compression damper.

- Turn the setting wheel in a clockwise direction (+) to decrease the deflection speed.
- ▶ Turn the setting wheel in an anti-clockwise direction (-) to increase the deflection speed.

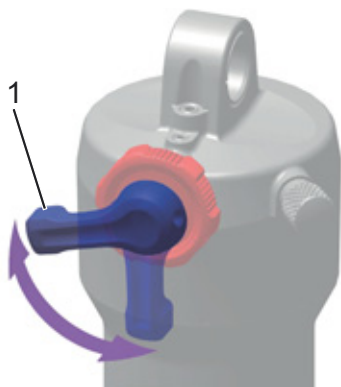

Figure 79: Setting the compression damper strength using the rear frame damper setting lever (1)

6.15 Gear shift

The selection of the appropriate gear is a prerequisite for a physically comfortable ride and making sure that the electric drive system functions properly. The ideal pedalling frequency is between 70 and 80 revolutions per minute.

- ▶ It is advisable to stop pedalling briefly when changing gears. This makes it easier to switch gears and reduces wear on the drivetrain.

6.15.1 Selecting gears

Only applies to pedelecs with this equipment

The speed and range can be increased while applying the same force if you select the right gear. Use the derailleur gears.

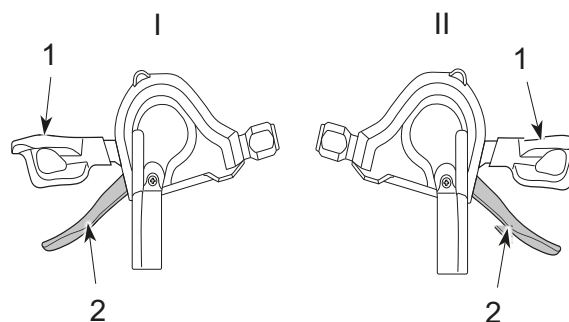

Figure 80: Down shifter (1) and up shifter (2) on the left (I) and right (II) gear shift

- ▶ Select the appropriate gear with the *shifter*.
 - ⇒ The gear shift switches the gear.
 - ⇒ The shifter returns to its original position.
- ▶ Clean the rear derailleur if the gear change blocks.

6.15.2 Using the hub gear

Only applies to pedelecs with this equipment



Crash caused by incorrect use

If the rider applies too much pressure on the pedals during a gear change and activates the shifter or changes several gears at a time, their feet may slip from the pedals. As a result, the pedelec may flip over or fall, which may cause injury.

Switching down several gears to a low gear may cause the twist grip outer sleeve to suddenly come off. This will not have an adverse effect on the twist grip's correct functioning since the outer guide returns to its original position after the gear change is complete.

- ▶ Apply little pressure on the pedals while changing gears.
- ▶ Never change more than one gear at a time.

Notice

The interior hub is not completely waterproof. If water gets into the hub, it may rust and the gear switch function may no longer function as a result.

- ▶ Never use the pedelec in places where water may get into the hub.

In rare cases, noises may be heard from the rear derailleur in the hub interior after a gear change. This is normal when gears are changed.

Do not detach the hub. If you need to detach it, contact your dealer.

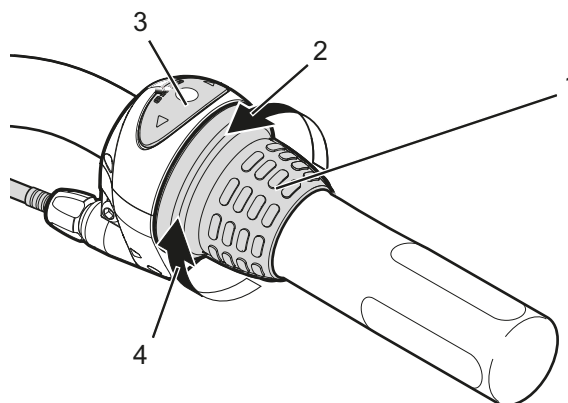

Figure 81: Example; Shimano Nexus gear shift: Twist grip (1) for the hub gear with its screen (3), the direction of rotation to switch up a gear (2) and the direction of rotation to switch down a gear (4)

- ▶ Turn the twist grip.
- ⇒ The gear shift switches the gear.
- ⇒ The number on the screen display shows the changed gear.

7 Cleaning and servicing

Cleaning check list

| | | |
|--------------------------|--|---------------------------|
| <input type="checkbox"/> | Clean the pedals | after each ride |
| <input type="checkbox"/> | Clean the suspension fork and, if necessary, rear frame damper | after each ride |
| <input type="checkbox"/> | Cleaning the battery | once a month |
| <input type="checkbox"/> | Chain (mainly tarmacked road) | every 250–300 km |
| <input type="checkbox"/> | Basic cleaning and preservation of all components | at least every six months |
| <input type="checkbox"/> | Clean the charger | at least every six months |
| <input type="checkbox"/> | Clean and lubricate the height-adjustable seat post | every six months |

Maintenance check list

| | | |
|--------------------------|---|---------------------------|
| <input type="checkbox"/> | Check USB rubber cover position | before each ride |
| <input type="checkbox"/> | Check for tyre wear | once a week |
| <input type="checkbox"/> | Check for rim wear | once a week |
| <input type="checkbox"/> | Check tyre pressure | once a week |
| <input type="checkbox"/> | Check brakes for wear | once a month |
| <input type="checkbox"/> | Check electrical cables and Bowden cables for damage and ensure they are fully functional | once a month |
| <input type="checkbox"/> | Check chain tension | once a month |
| <input type="checkbox"/> | Check tension of the spokes | every three months |
| <input type="checkbox"/> | Check the gear shift setting | every three months |
| <input type="checkbox"/> | Check suspension fork and, if necessary, rear frame damper for wear and ensure fully functional | every three months |
| <input type="checkbox"/> | Check for wear on brake discs | at least every six months |



Crash and falling caused by unintentional activation

There is a risk of injury if the drive system is activated unintentionally.

- ▶ Remove the battery before cleaning.

Servicing measures must be performed regularly. Contact your specialist dealer if you are unsure.

7.1 Cleaning after each ride

Required tools and cleaning agents:

- Cloth
- Air pump
- Brush
- Water
- Dish-washing liquid
- Bucket

7.1.1 Cleaning the suspension fork

- ▶ Remove dirt and deposits from the stanchions and deflector seals with a damp cloth.
- ▶ Check the stanchions for dents, scratches, staining or leaking oil.
- ▶ Check the air pressure.
- ▶ Lubricate the dust seals and stanchions.

7.1.2 Cleaning the rear frame damper

- ▶ Remove dirt and deposits from the damper body with a damp cloth.
- ▶ Check rear frame damper for dents, scratches, staining or leaking oil.

7.1.3 Cleaning the pedals

- ▶ Clean with a brush and soapy water after riding through dirt or rain.
- ⇒ Service the pedals after cleaning.

7.2 Basic cleaning



CAUTION

Crash caused by brake failure

The braking effect may be unusually poor temporarily after cleaning, servicing or repairs. This may cause a crash with injuries.

- ▶ Never apply care products or oil to the brake discs or brake linings, or the braking surfaces on the rims.
- ▶ After cleaning, servicing or repair, carry out a few test brake applications.

Notice

Water may enter the inside of the bearings if you use a steam jet. This dilutes the lubricant inside, the friction increases and, as a result, the bearings are permanently damaged in the long term.

- ▶ Never clean the pedelec with a pressure washer.

Greased parts, such as the seat post, the handlebars or the stem, may no longer be safely and reliably clamped.

- ▶ Never apply grease or oil to clamping sections.

Required tools and cleaning agents:

- Cloths
- Sponge
- Air pump
- Brush
- Toothbrush
- Paintbrush
- Watering can
- Bucket
- Water
- Dish-washing liquid
- Degreaser
- Lubricant
- Brake cleaner or spirit

- ✓ Remove battery and display before basic cleaning.

7.2.1 Cleaning the frame

- 1 Soak the entire frame with dish-washing detergent if the dirt is thick and ingrained.
- 2 After leaving it to soak for a short time, remove the dirt and mud with a sponge, brush and toothbrushes.
- 3 Use a watering can or your hand to rinse the frame.
- 4 Service the frame after cleaning.

7.2.2 Cleaning the stem

- 1 Clean stem with a cloth and soapy water.
- 2 Service the stem after cleaning.

7.2.3 Cleaning the wheel



WARNING

Crash caused by braking hard on rims

A rim can break and block the wheel if you brake hard. This may cause a crash with serious injuries.

Check rim *wear* on a regular basis.

- 1 Check the tyres, rims, spokes and spoke nipples for any damage when cleaning the wheel.
- 2 Use a sponge and a brush to clean the hub and spokes from the inside to the outside.
- 3 Clean the rim with a sponge.

7.2.4 Cleaning the drive elements

- 1 Spray the cassette, the chain wheels and the front derailleur with a degreasing agent.
- 2 Clean coarse dirt with a brush after soaking for a short time.
- 3 Wash down all parts with dish-washing detergent and a toothbrush.
- 4 Service the drive elements after cleaning.

7.2.5 Cleaning the rear frame damper

- ▶ Clean rear frame damper with a cloth and soapy water.

7.2.6 Cleaning the chain

Notice

- ▶ Never use aggressive (acid-based) cleaners, rust removers or degreasers when cleaning the chain.
- ▶ Never use chain cleaning devices or chain cleaning baths.

- 1 Slightly dampen a brush with dish-washing liquid. Brush both sides of the chain.
- 2 Dampen a cloth with soapy water. Place the cloth on the chain.
- 3 Hold and apply slight pressure while slowly turning the rear wheel, so the chain passes through the cloth.
- 4 If the chain is still dirty afterwards, clean with lubricant.
- 5 Service the chain after cleaning.

7.2.7 Cleaning the battery

CAUTION

Risk of fire and explosion due to penetration by water

The battery is only protected from simple spray water. Penetration by water can cause a short circuit. The battery may self-ignite and explode.

- ▶ Never clean the battery with a pressure washer, water jet or compressed air.
- ▶ Keep contacts dry and clean.
- ▶ Never immerse the battery in water.
- ▶ Never use cleaning agents.
- ▶ Remove the battery from the pedelec before cleaning.

Notice

- ▶ Never clean the battery with solvents, such as oil, thinners, alcohol or corrosion protection, or with cleaning agents.
- ▶ Clean the battery electrical connections with a dry cloth or paintbrush only.
- ▶ Wipe off the decorative sides with a damp cloth.

7.2.8 Cleaning the display

Notice

If water enters into the display screen, it will be permanently damaged.

- ▶ Never immerse the display in water.
- ▶ Never clean with a pressure washer, water jet or compressed air.
- ▶ Never use cleaning agents.
- ▶ Remove the display from the pedelec before cleaning.
- ▶ Carefully clean the display with a damp, soft cloth.

7.2.9 Cleaning the drive unit

CAUTION

Burns from hot drive

The drive cooler can become extremely hot during use. Contact may cause burns.

- ▶ Leave the drive unit to cool before cleaning.

Notice

If water enters into the drive unit, the unit will be permanently damaged.

- ▶ Never immerse the drive unit in water.
- ▶ Never clean with a pressure washer, water jet or compressed air.
- ▶ Never use cleaning agents.
- ▶ Never open battery.
- ▶ Carefully clean the drive unit with a damp, soft cloth.

7.2.10 Cleaning the brake



WARNING

Brake failure due to water penetration

The brake seals are unable to withstand high pressures. Damaged brakes can fail and cause an accident with injury.

- ▶ Never clean the pedelec with a pressure washer or compressed air.
- ▶ Take great care when using a hosepipe. Never point the water jet directly at the seal section.

- ▶ Clean brake and brake discs with a brush, water and dish-washing detergent.
- ▶ Clean brake discs thoroughly with brake cleaner or spirit.

7.3 Servicing

Required tools and cleaning agents:

- Cloths
- Toothbrushes
- Dish-washing liquid
- Care oil for frames
- Silicone or Teflon oil
- Acid-free lubricating grease
- Fork oil
- Chain oil
- Degreaser
- Spray oil
- Teflon spray

7.3.1 Servicing the frame

- ▶ Dry the frame.
- ▶ Spray with care oil.
- ▶ Clean off the care oil again after a short time.

7.3.2 Servicing the stem

- ▶ Apply silicone or Teflon oil to the stem shaft tube and the quick release lever pivot point.
- ▶ If you have speedlifter Twist, also apply oil to the unlocking bolt using the groove in the speedlifter body.
- ▶ Apply a little acid-free lubricant grease between the stem quick release lever and the sliding piece to reduce the quick release lever operating force.

7.3.3 Servicing the fork

- ▶ Treat the dust seals with fork oil.

7.3.4 Servicing the drive elements

- 1 Spray the cassette, the chain wheels and the front derailleur with a degreasing agent.
- 2 Clean coarse dirt with a brush after soaking for a short time.
- 3 Wash down all parts with dish-washing detergent and a toothbrush.

7.3.5 Servicing the pedals

- ▶ Treat pedals with spray oil.

7.3.6 Servicing the chain

- ▶ Grease the chain thoroughly with chain oil.

7.3.7 Servicing the drive elements

- ▶ Service front and rear derailleur articulated shafts and jockey wheels with Teflon spray.

7.4 Maintenance



CAUTION

Crash and falling caused by unintentional activation

There is a risk of injury if the drive system is activated unintentionally.

- ▶ Remove the battery before maintenance.

The following maintenance measures must be performed on a regular basis.

7.4.1 Wheel



WARNING

Crash caused by braking hard on rims

A rim can break and block the wheel if you brake hard. This may cause a crash with serious injuries.

- ▶ Check rim wear on a regular basis.

Notice

If the tyre pressure is too low in the tyre, the tyre does not achieve its load bearing capacity. The tyre is not stable and may come off the rim.

If the tyre pressure is too high, the tyre may burst.

- ▶ Check the tyre pressure against the specifications
- ▶ *Adjust the tyre pressure as necessary.*

- 1 Check the *tyres* for wear.
- 2 Check the *tyre pressure*.
- 3 Check the *rims* for wear.
 - ⇒ The rims of a rim brake with invisible wear indicator are worn as soon as the wear indicator becomes visible in the area of the rim joint.
 - ⇒ The rims with visible wear indicator are worn as soon as the black, all-round groove on the pad friction surface is no longer visible. We recommend that you also replace the *rims* with every second brake lining replacement.
- 4 Check the tension of the spokes.

7.4.1.1 Checking the tyres

- ▶ Check the tyres for wear. The tyre is worn if the anti-puncture protection or the carcass cords are visible.
- ⇒ A specialist dealer will need to change the tyre if it is worn.

7.4.1.2 Checking the rims

- ▶ Check the *rims* for wear. The rims are worn as soon as the black, all-round groove on the pad friction surface becomes invisible.
- ⇒ Contact your specialist dealer to have the rims replaced. We recommend that you also replace the *rims* at the same time as every second brake lining replacement.

7.4.1.3 Checking and adjusting the tyre pressure – Dunlop valve

Only applies to pedelecs with this equipment



The tyre pressure cannot be measured on the simple Dunlop valve. The tyre pressure is therefore measured in the filling hose when pumping slowly with the bicycle pump.

It is recommendable to use a bicycle pump with a pressure gauge. The operating instructions for the bicycle pump must be adhered to.

- 1 Unscrew and remove the valve cap.
- 2 Connect the bicycle pump.
- 3 Pump up the tyre slowly and pay attention to the tyre pressure in the process.
- 4 Correct the tyre pressure according to specifications in the Pedelec pass.
- 5 If the tyre pressure is too high, unfasten the union nut, let air out and re-tighten the union nut.
- 6 Remove the bicycle pump.
- 7 Screw the valve cap tight.
- 8 Screw the rim nut gently against the rim with the tips of your fingers.

7.4.1.4 Checking and adjusting the tyre pressure – presta valve

Only applies to pedelecs with this equipment



✓ It is recommendable to use a bicycle pump with a pressure gauge. The operating instructions for the bicycle pump must be adhered to.

- 1 Unscrew and remove the valve cap.
- 2 Open the knurled nut around four turns.
- 3 Carefully apply the bicycle pump so that the valve insert is not bent.

- 4 Pump up the tyre slowly and pay attention to the tyre pressure in the process.
- 5 Correct the tyre pressure as per the specifications on the tyre.
- 6 Remove the bicycle pump.
- 7 Tighten the knurled nut with your fingers.
- 8 Screw the valve cap tight.
- 9 Screw the rim nut gently against the rim with the tips of your fingers.

7.4.1.5 Checking and adjusting the tyre pressure – Schrader valve

Only applies to pedelecs with this equipment



✓ It is recommended to use a bicycle pump with a pressure gauge. The operating instructions for the bicycle pump must be adhered to.

1 Unscrew and remove the valve cap.

2 Attach the bicycle pump.

3 Pump up the tyre slowly and pay attention to the tyre

pressure in the process.

⇒ The tyre pressure has been adjusted as per the specifications.

- 4 Remove the bicycle pump.
- 5 Screw the valve cap tight.
- 6 Screw the rim nut (1) gently against the rim with the tips of your fingers.

7.4.2 Brake system



Crash caused by brake failure

Worn brake discs and brake linings and a lack of hydraulic fluid in the brake cable reduce the braking power. This may cause a crash with injuries.

- ▶ Check the brake disc, brake linings and hydraulic brake system on a regular basis. Contact your specialist dealer if any of these components are worn.

The maintenance interval for the brake depends on the weather conditions and how frequent the pedelec is used. If the pedelec is used under extreme conditions such as rain, dirt or high mileage, maintenance must be performed more frequently.

7.4.3 Checking the brake linings for wear

Check brake linings after brake has been fully applied 1,000 times.

1 Check that the brake linings are no less than 1.8 mm wide at any point and no less than 2.5 mm between the brake lining and supporting plate.

2 Push brake lever and hold. In doing so, check the transport safety wear gauge can fit between the brake lining supporting plates.

⇒ The brake linings have not reached their wear limit. Contact your specialist dealer if any of these components are worn.

7.4.4 Checking the pressure point

▶ Push brake lever and hold several times.

⇒ If you are unable to clearly detect the pressure point and it changes, the brake needs to be vented. Contact your specialist dealer.

7.4.5 Checking the brake discs for wear

▶ Check that the brake disc is no less than 1.8 mm at any point.

⇒ The brake discs have not reached their wear limit yet; brake discs need to be replaced if they have. Contact your specialist dealer.

7.4.6 Electrical cables and brake cables

▶ Check all visible electrical cables and cables for damage. If the sheathing is compressed, a brake defective or a light does not work, the pedelec will need to be removed from service until the lines or cables have been repaired. Contact your specialist dealer.

7.4.7 Gear shift

▶ Check the gear shift and the *shifter* or the *twist grip* setting and adjust it as necessary.

7.4.8 Stem

- ▶ The stem and quick release system must be inspected at regular intervals. The specialist dealer should adjust them if necessary.
- ▶ If the hexagon socket head screw is also loosened, the headset backlash also needs to be adjusted. Medium-strength thread locker, such as Loctite blue, then needs to be applied to the loosened screws and the screws tightened as per specifications.
- ▶ Contact your specialist dealer if there is any wear or signs of corrosion.

7.4.9 USB port

Notice

Any moisture which enters through the USB port may trigger a short circuit in the *display*.

- ▶ Regularly check the position of the *cover on the USB port* and adjust it as necessary.

7.4.10 Checking the belt and chain tension

Notice

Excessive chain tension increases wear.

If the chain tension is too low, there is a risk that the *chain* or the *drive belt* will slip off the *chain wheels*.

- ▶ Check the chain tension once a month.

- 1 Check the chain tension in three or four positions, turning the crank a full revolution.

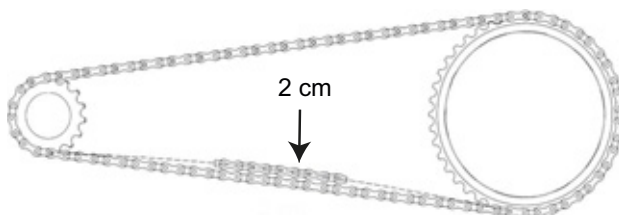

Figure 82: Checking the chain tension

- 2 If the *chain* can be pushed more than 2 cm, the *chain* or *drive belt* will need to be tensioned again by the specialist dealer.
 - 3 If the *chain* or the *drive belt* can only be pushed up and down less than 1 cm, you will need to slacken the *chain* or the *drive belt*.
 - ⇒ The optimum chain tension is achieved if the *chain* or the *drive belt* can be pushed a maximum of 2 cm in the middle between the pinion and the toothed wheel. The crank must also turn without resistance.
 - ⇒ If a hub gear is featured, the rear wheel must be pushed backwards or forwards to tighten the chain. Contact your specialist dealer.
- ▶ Check the handlebar grip is firmly in position.



8 Maintenance

WARNING

Injury due to damaged brakes

Special tools and specialist knowledge are required to repair the brakes. Incorrect or unauthorised assembly can damage the brakes. This may lead to an accident with injuries.

- ▶ Only specialist dealers may carry out repairs on brakes.
- ▶ Only carry out work or changes, such as dismantling, sanding or painting, which are permitted and described in the brake operating instructions.

Injury to the eyes

Problems may arise if the settings are not made properly and you may sustain serious injuries as a result.

Always wear safety glasses to protect your eyes when carrying out maintenance work such as replacing components.

CAUTION

Crash and falling caused by unintentional activation

There is a risk of injury if the drive system is activated unintentionally.

- ▶ Remove the battery before inspection.

Crash caused by material fatigue

If the service life of a component has expired, the component may suddenly fail. This may cause a crash with injuries.

- ▶ Have the specialist dealer carry out basic cleaning of the pedelec every six months, preferably at the same time as the required servicing work.

CAUTION

Hazard for the environment due to toxic substances

The brake system contains toxic and environmentally harmful oils and lubricants. Such fluids will contaminate if they enter the sewers or groundwater.

- ▶ Dispose of lubricants and oils left over after repairs in an environmentally responsible way
- ▶ in accordance with statutory regulations.

Notice

The motor is maintenance-free and may only be opened by qualified specialist personnel.

- ▶ Never open the motor.

You must have the specialist dealer perform maintenance every six months as a minimum. This is the only way to ensure that the pedelec remains safe and fully functional.

Technical expertise, special tools and special lubricants are required no matter whether disc brakes need replacing, brakes venting or wheels changing. The pedelec may become damaged if the stipulated maintenance intervals and procedures are not carried out. That is why only specialist dealers may carry out maintenance.

- ▶ The retailer will check the pedelec based on the maintenance table in the appendix.
- ▶ The specialist dealer will inspect the pedelec for any signs of material fatigue during basic cleaning.
- ▶ The specialist dealer will check the software version of the drive system and update it. The electrical connections are checked, cleaned and preservative agent is applied. The electrical cables are inspected for damage.
- ▶ The specialist dealer will dismantle and clean the entire suspension fork interior and exterior. They will clean and lubricate the dust seals and slide bushings, check the torques and adjust the fork to the rider's preferred position. They will also replace the sliding collar if the clearance is too great (more than 1 mm on the fork bridge).

- ▶ The specialist dealer will fully inspect the interior and exterior of the rear frame damper, overhaul the rear frame damper, replace all air seals on air forks, overhaul the air suspension, change the oil and replace the dust wipers.
- ▶ They will pay particular attention to rim and brake wear. The spokes are re-tightened in accordance with the findings.

8.1 Axle with quick release



Crash caused by unfastened quick release

A faulty or incorrectly installed quick release may become caught in the brake disc and block the wheel. This will cause a crash.

- ▶ Install the front wheel quick release lever on the opposite side to the brake disc.

Crash caused by faulty or incorrectly installed quick release

The brake disc becomes very hot during operation. Parts of the quick release may become damaged as a result. The quick release comes loose. This will cause a crash with injuries.

- ▶ The front wheel quick release lever and the brake disc must be situated on opposite sides.

Crash caused by incorrectly set clamping force

Excessively high clamping force will damage the quick release and cause it to lose its function.

Insufficient clamping force will cause a detrimental transmission of force. The suspension fork or the frame may break. This will cause a crash with injuries.

- ▶ Never fasten a quick release using a tool (e.g. hammer or pliers).

Only use the clamping lever with the specified set clamping force.

8.1.1 Checking the quick release

- ▶ Check the position and clamping force of the quick release lever. The quick release lever must be flush with the lower housing. You must be able to see a slight impression on the palm of your hand when you close the quick release lever.



Figure 83: Adjusting the quick release clamping force

- ▶ Use a 4 mm hexagon socket spanner to adjust the clamping lever clamping force if required. Afterwards, check the quick release lever position and clamping force.

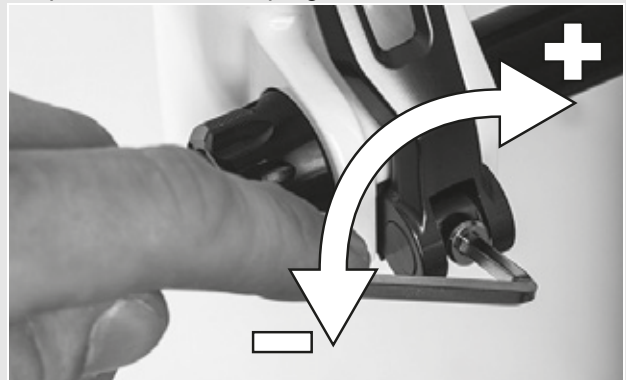

Figure 84: Adjusting the quick release clamping force

8.2 Adjusting the gear shift

If you cannot select the gears effortlessly, you will need to adjust the setting for the shift cable tension.

- ▶ Carefully pull the *adjusting sleeve* away from the shifter housing, turning it as you do so.
- ▶ Check the gear shift function after each adjustment.

8.2.1 Cable-operated gear shift, single-cable

Only applies to pedelecs with this equipment

- ▶ For a smooth gear shift, adjust the adjusting sleeves on the shifter housing.



Figure 85: Adjusting sleeve (1) for the single-cable, cable-operated gear shift with shifter housing (2), example

8.2.2 Cable-operated gear shift, dual-cable

Only applies to pedelecs with this equipment

- ▶ For a smooth gear shift, set the adjusting sleeves underneath the chain stay on the frame.
- ▶ The shift cable has around 1 mm play when it is pulled out gently.

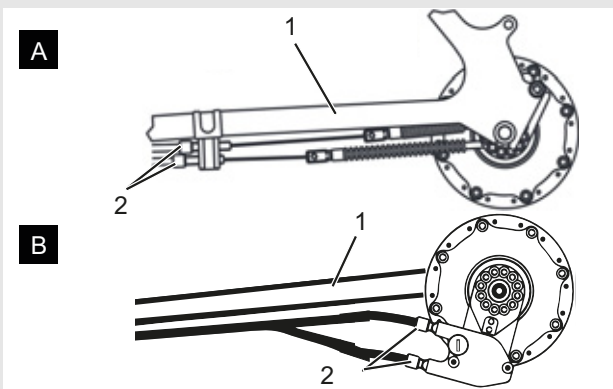

Figure 86: Adjusting sleeves (2) on two alternative versions (A and B) of a dual-cable, cable-operated gear shift on the chain stay (1)

8.2.3 Cable-operated twist grip, dual-cable

Only applies to pedelecs with this equipment

- ▶ For a smooth gear shift, set the adjusting sleeves on the shifter housing.
- ⇒ There is noticeable play of around 2–5 mm (1/2 gear) when twisting the twist grip.

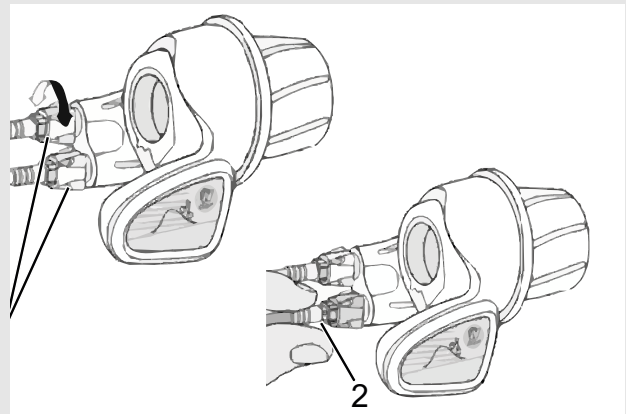

Figure 87: Twist grip with adjusting sleeves (1) and play of the gear shift (2)

9 Troubleshooting, fault clearance and repair

9.1 Troubleshooting and fault clearance



Risk of fire and explosion due to faulty battery

The safety electronics may fail if the battery is damaged or faulty. The residual voltage can cause a short circuit. Batteries may self-ignite and explode.

- ▶ Batteries with external damage must be removed from service immediately.
- ▶ Never allow damaged batteries to come into contact with water.
- ▶ If a battery is dropped or struck but shows no signs of external damage, remove it from service and observe it for at least 24 hours.
- ▶ Faulty batteries are hazardous goods. Dispose of faulty batteries properly and as quickly as possible.
- ▶ Store in a dry place until disposal. Never store in the vicinity of flammable substances.

Never open or repair the battery.

The components of the drive system are checked constantly and automatically. If an error is detected, the respective error code appears on the *display*. The drive may be shut off automatically, depending on the type of error.

9.1.1 The drive system or display do not start up

If the display and/or the drive system do not start up, proceed as follows:

- ▶ Check whether the battery is switched on. If not, start the battery.
- ⇒ Contact specialist dealer if the battery level indicator LEDs do not light up.
- ▶ If the LEDs on the battery level indicator light up, but the drive system does not start up, remove the battery.

- ▶ Insert the battery.
- ▶ Start the drive system.
- ▶ If the drive system does not start up, remove the battery.
- ▶ Clean all the contacts with a soft cloth.
- ▶ Insert the battery.
- ▶ Start the drive system.
- ▶ If the drive system does not start up, remove the battery.
- ▶ Fully charge the battery.
- ▶ Insert the battery.
- ▶ Start the drive system.
- ▶ If the drive system does not start up, remove the display.
- ▶ Fasten the display.
- ▶ Start the drive system.
- ▶ Contact your specialist dealer if the drive system does not start up.

9.1.2 Error messages

If an error message is displayed, run through the following actions:

- ▶ Make a note of the system message.
- ▶ Shut off and re-start the drive system.
- ▶ If the system message is still displayed, remove and then re-insert the battery.
- ▶ Re-start the drive system.
- ▶ If the system message is still displayed, contact your specialist dealer.

9.2 Switching on

| Symptom | Cause | Remedy |
|---|---|---|
| A torque sensor error is displayed on starting up. | Are you applying pressure to the pedals when switching on? | ▶ Press the On-Off button again and avoid applying pressure to the pedals. |
| The pedelec has only a little power assistance after starting up. | | |
| An error is displayed on starting up. | Are you pressing other buttons while pushing the On-Off button? | ▶ Press the On-Off button again and avoid pushing other buttons at the same time. |

Table 36: Error solution when switching on

9.3 Assistance function

| Symptom | Cause | Remedy |
|---|---|--|
| Assistance is not available. | Is the battery charged sufficiently? | ▶ Check the battery level. ▶ If the battery is almost flat, recharge it. |
| | Are you riding up long inclines in summer weather or have you been carrying a heavy load for a long time? The battery may be too hot. | ▶ Turn off the drive system. ▶ Wait a while and then check again. |
| | The drive unit (DU-E8000), the bicycle computer (SC-E8000/SC-E6010) or the assistance switch (SW-E8000-L/SW-E6000/SW-E6010) may be connected incorrectly or one or more of them may have a problem. | ▶ Contact your specialist dealer. |
| | Is the speed too high? | ▶ Check the on-screen indicators. ▶ The electronic gear assistance only works up to a maximum speed of 25 km/h. |
| Assistance is not available. | Are you pedalling? | ▶ The pedelec is not a motorbike. You also need to pedal. |
| | Is the assistance mode set to [OFF]? | ▶ Set the assistance mode to a different level of assistance than [OFF]. ▶ Contact your specialist dealer if you still feel that the pedelec does not provide assistance. |
| | Is the system switched on? | ▶ Press the battery on-off button to switch it on again. |
| The assisted journey distance is too short. | The journey distance can be shorter depending on the road conditions, the gear level and the entire light usage time. | ▶ Check the battery level. ▶ If the battery is almost flat, recharge it. |
| | The battery does not perform as well in winter weather. | This does not indicate a problem. |
| | The battery is a consumable. Repeated charging and long periods of use cause the battery to degrade (loss of power). | ▶ If the distance you can cover with one single charge is very short, replace the battery with a new one. |
| | Is the battery fully charged? | ▶ If the distance covered with a fully charged battery has become shorter, the battery may be affected. Replace the battery with a new one. |

Table 37: Level of assistance error solution

| Symptom | Cause | Remedy |
|---------------------------|--|--|
| It is difficult to pedal. | Are the tyres pumped to an adequate pressure? | ▶ Pump up the tyres. |
| | Is the assistance mode set to OFF? | ▶ Select the level of assistance [BOOST]. ▶ Contact your specialist dealer if you still feel that the pedelec does not provide assistance. |
| | The battery charge might be low. | ▶ Check how powerful assistance is again after charging the battery. ▶ Contact your specialist dealer if you still feel that the pedelec does not provide assistance. |
| | Have you switched on the system with your foot on the pedal? | ▶ Switch the system on again without applying pressure to the pedal. ▶ Contact your specialist dealer if you still feel that the pedelec does not provide assistance. |

Table 37: Level of assistance error solution

9.4 Rechargeable battery

| Symptom | Cause | Remedy |
|--|--|---|
| The battery discharges quickly. | The battery may be at the end of its service life. | ▶ Replace the old battery with a new one. |
| The battery cannot be recharged. | Is the charger mains plug firmly connected to the socket? | ▶ Pull out the charger mains plug and reconnect it again. ▶ Try charging again. ▶ If the battery still won't recharge, contact your specialist dealer. |
| | Is the charger plug firmly connected to battery? | ▶ Pull out the charger mains plug and reconnect it again. ▶ Try charging again. ▶ If the battery still won't recharge, contact your specialist dealer. |
| | Is the adapter firmly connected to the charger plug or the battery's charging port? | ▶ Connect the adapter firmly to the charger plug or the battery's charging port. ▶ Re-start the charging process. ▶ Contact your specialist dealer if the battery still does not charge. |
| | Is the battery, the connection terminal for the battery charger or the charger adapter dirty? | ▶ Wipe the connection terminal with a dry cloth to clean it. ▶ Try charging again. ▶ If the battery still won't recharge, contact your specialist dealer. |
| The battery does not start charging when the charger is connected. | The battery may be at the end of its service life. | ▶ Replace the old battery with a new one. |
| The battery and charger become hot. | The temperature of the battery or the charger may have exceeded the operating temperature range. | ▶ Stop the charging process. ▶ Wait a while and then start charging again. ▶ If the battery is too hot to touch, there might be a problem with the battery. Contact your specialist dealer. |
| The charger is hot. | If the charger is used continuously to charge batteries, it may become hot. | ▶ Wait a while before using the charger again. |
| The LED on the charger does not light up. | Is the charger plug firmly connected to battery? | ▶ Check the connection to the external body before inserting the charger plug again. ▶ If nothing changes, contact your specialist dealer. |
| | Is the battery fully charged? | The LED on the battery charger will go out when the battery is fully charged. This is not a malfunction. ▶ Pull out the charger mains plug and reconnect it again. ▶ Then try charging again. ▶ If the LED on the charger still does not light up, contact your specialist dealer. |

Table 38: Error solution for battery



| Symptom | Cause | Remedy |
|-------------------------------------|-------|--|
| The battery cannot be removed. | | ▶ Contact your specialist dealer. |
| The battery cannot be inserted. | | ▶ Contact your specialist dealer. |
| Fluid is leaking from the battery. | |  WARNING |
| | | <ul style="list-style-type: none"> ▶ Move away from the battery immediately. ▶ Contact the fire service immediately. ▶ Observe all the safety instructions in Section 2 Safety. |
| There is an unusual smell. | |  WARNING |
| | | <ul style="list-style-type: none"> ▶ Move away from the battery immediately. ▶ Contact the fire service immediately. ▶ Observe all the safety instructions in Section 2 Safety. |
| Fumes are emitted from the battery. | |  WARNING |
| | | <ul style="list-style-type: none"> ▶ Move away from the battery immediately. ▶ Contact the fire service immediately. ▶ Observe all the safety instructions in Section 2 Safety. |

Table 38: Error solution for battery

9.5 Lighting

| Symptom | Cause | Remedy |
|--|---|---|
| The front light or rear light does not go on, even when the switch is pressed. | The basic settings in the electric drive system have probably been configured incorrectly. The light is defective. | <ul style="list-style-type: none"> ▶ Take the pedelec out of service immediately. ▶ Contact your specialist dealer. |

Table 39: Error solution for battery

9.6 Display

| Symptom | Cause | Remedy |
|---|--|--|
| No data are shown on the monitor if you press the on-off button on the battery. | The battery charge level may be insufficient. | <ul style="list-style-type: none"> ▶ Charge the battery. ▶ Switch the power on. |
| | Is the power switched on? | ▶ Keep the battery on-off button pressed down to switch on the power again. |
| | Is the battery charged? | ▶ If the battery is fitted to the pedelec and is being charged, it cannot be switched on. Stop the charging process. |
| | Is the connector fitted to the power cable correctly? | ▶ Check whether the power cable connector connecting the motor unit to the drive unit has not disconnected. If you are not sure, contact your specialist dealer. |
| | A component may be connected which the system is unable to recognise. | ▶ Contact your specialist dealer. |
| The gear level is not shown on the display. | The gear level is only shown if the electronic gear shift is used. | ▶ Check whether the power cable pug has been disconnected. If you are not sure, contact your specialist dealer. |
| The settings menu cannot be opened while you are riding. | The product is designed in such a way that the settings menu cannot be opened if the system detects that someone is riding the pedelec. This is not a malfunction. | ▶ Stop the pedelec and then adjust the settings. |
| The time display is flashing "0:00". | The coin cell in the display has come to the end of its service life. | ▶ Replace the coin cell in the display. |

Table 40: Error solution for the display

9.7 Miscellaneous

| Symptom | Cause | Remedy |
|--|--|---|
| Two beeps will sound if a switch is pressed but the switch cannot be operated. | Pressed switch mode has been deactivated. | ▶ This is not a malfunction. |
| Three beeps are sounded. | A fault or warning has occurred. | ▶ This occurs when a warning or an error is shown on the display screen. Follow the instructions for the code indicated on screen in Section 6.2 System Messages. |
| When you use an electronic gear shift, you can feel that pedal assistance becomes weaker when the gear is changed. | This is because the computer sets the pedal assistance to the optimum level. | ▶ This is not a malfunction. |
| You hear a noise after shifting gears. | | ▶ Contact your specialist dealer. |
| It is normal to hear a noise coming from the rear wheel when cycling as normal. | The gear shift setting may not have been made properly. | ▶ Contact your specialist dealer. |
| If you stop the pedelec, gear transmission does not switch to the position pre-configured in the functional feature. | You may have applied too much pressure onto the pedals. | ▶ It is easier to change gears if you press onto the pedals gently. |

Table 41: Error solution for battery

9.8 Repair

Special knowledge and tools are required for many repairs. That is why only a specialist dealer may perform repairs such as:

- Replacing tyres and rims
- Replacing brake pads and brake linings
- Replacing and tensioning the chain.

9.8.1 Use original parts and lubricants only

The individual pedelec parts have been carefully selected and matched to one other.

Only original parts and lubricants must be used for maintenance and repair.

The constantly updated accessory approval and parts list are Section 11, Documents and Drawings.

9.8.2 Replacing the lighting

- ▶ Only use components of the respective power class for replacement.

9.8.3 Adjusting the headlight

- ▶ The *headlight* must be set, so that its light beam shines on the road 10 m in front of the pedelec.

10 Recycling and disposal

WARNING

Risk of fire and explosion

The safety electronics may fail if the battery is damaged or faulty. The residual voltage can cause a short circuit. The battery may self-ignite and explode.

- ▶ Remove battery with any external damage from service immediately and never recharge it.
- ▶ If the battery becomes deformed or begins to smoke, keep at a safe distance, disconnect the power supply at the socket, and notify the fire service immediately.
- ▶ Never extinguish damaged batteries with water or allow them to come into contact with water.
- ▶ Faulty batteries are hazardous goods. Dispose of faulty batteries properly as quickly as possible.
- ▶ Store in a dry place until disposal. Never store in the vicinity of flammable substances.

Never open or repair the battery.

CAUTION

Chemical burns to the skin and eyes

Liquids and vapours may leak from a damaged or faulty battery. They can irritate the airways and cause burns.

- ▶ Avoid contact with leaked liquids.
- ▶ Immediately consult a doctor in case of contact with the eyes or any discomfort.
- ▶ In case of contact with the skin, rinse off immediately with water.
- ▶ Ventilate the room well.

CAUTION

Hazard for the environment

The fork, rear frame damper and hydraulic brake system contain toxic and environmentally harmful oils and lubricants. Such fluids will contaminate if they enter the sewers or groundwater.

- ▶ Dispose of lubricants and oils in an environmentally responsible way in accordance with statutory regulations.



This device is marked according to the European Directive 2012/19/EU on waste electrical and electronic equipment – WEEE and the European Directive 2006/66/EC on accumulators.



The directive provides the framework for the return and recycling of used devices across the EU. As a consumer, you are legally required to return all used batteries of any type. It is forbidden to dispose of batteries in domestic waste. The manufacturer is obliged to take back used and old batteries free of charge as per Section 9 German Batteries Act. This means you meet statutory obligations and help to protect the environment. The pedelec, battery, motor, display screen and charger are recyclable materials. You must dispose of and recycle them separately from the domestic waste in compliance with applicable statutory regulations. Sorted waste collection and recycling saves on raw material reserves and ensures that all the regulations for health and environmental protection are met when the product and/or the battery are recycled.

- ▶ Never dismantle the pedelec, batteries or charger for disposal.
- ▶ The pedelec, display screen, the unopened and undamaged battery and the charger can be returned to any specialist dealer free of charge. Depending on the region, further disposal options may be available.

Store the individual parts of the decommissioned pedelec in a dry place, free from frost, where they are protected from direct sunlight.

11 Documents

11.1 Parts list

There was no information relating to a parts list yet at the time of going to press. You'll find the information in the latest *operating instructions*.

11.2 Assembly report

Date:

Frame number:

| Components | Description | | Criteria | | Measures if rejected |
|--|---|---------------------|------------|--------------------------------|---|
| | Assembly/inspection | Tests | Acceptance | Rejection | |
| Front wheel | Assembly | | O.K. | Loose | Adjust quick release |
| Kickstand | Check mount fastening | Functional check | O.K. | Loose | Retighten screws |
| Tyres | | Tyre pressure check | O.K. | Tyre pressure too low/too high | Adjust tyre pressure |
| Frame | Check for damage – fracture, scratches | | O.K. | Damage detected | <i>Take out of operation, new frame</i> |
| Handles, coverings | Check mount fastening | | O.K. | Not provided | Retighten screws, new handles or coverings as specified in parts list |
| Handlebars, stem | Check mount fastening | | O.K. | Loose | Retighten screws; new stem as specified in parts list if necessary |
| Steering headset | Check for damage | Functional check | O.K. | Loose | Retighten screws |
| Saddle | Check mount fastening | | O.K. | Loose | Retighten screws |
| Seat post | Check mount fastening | | O.K. | Loose | Retighten screws |
| Protective plate | Check mount fastening | | O.K. | Loose | Retighten screws |
| Pannier rack | Check mount fastening | | O.K. | Loose | Retighten screws |
| Attachments | Check mount fastening | | O.K. | Loose | Retighten screws |
| Bell | | Functional check | O.K. | No ring, too quiet, missing | New bell as specified in the parts list |
| Suspension elements | | | | | |
| Fork, suspension fork | Check for damage | | O.K. | Damage detected | New fork as specified in the parts list |
| Rear frame damper | Check for damage | | O.K. | Damage detected | New fork as specified in the parts list |
| Suspension seat post | Check for damage | | O.K. | Damage detected | New fork as specified in the parts list |
| Brake system | | | | | |
| Brake lever | Check mount fastening | | O.K. | Loose | Retighten screws |
| Brake fluid | Check fluid level | | O.K. | Too little | Refill with brake fluid; new brake hoses if damaged |
| Brake linings | Check brake linings, brake discs or rims for damage | | O.K. | Damage detected | New brake linings, brake discs or rims |
| Back-pedal brake braking armature | Check mount fastening | | O.K. | Loose | Retighten screws |
| Light system | | | | | |
| Rechargeable battery | First examination | | O.K. | Error message | <i>Take out of service</i> ; contact battery manufacturer, new battery |
| Light cabling | Connections, correct wiring | | O.K. | Cable defective, no light | New cabling |
| Rear light | Side light | Functional check | O.K. | No constant light | <i>Take out of service</i> ; new rear light as specified in parts list; replace battery if necessary |
| Front light | Side light, daytime riding light | Functional check | O.K. | No constant light | <i>Take out of service</i> ; new front light as specified in parts list; replace battery if necessary |
| Reflectors | All complete, state, fastening | | O.K. | Damaged or not all complete | New reflectors |

| Components | Description | | Criteria | | Measures if rejected |
|--|------------------------------------|-------------------|-------------------|---|---|
| Drive/gear shift | | | | | |
| Chain/cassette/pinion/chainring | Check for damage | | O.K. | Damage | Refasten if necessary or replace as specified in parts list |
| Chain guard/spoke guard | Check for damage | | O.K. | Damage | Replace as specified in parts list |
| Bottom bracket axle/crank | Check mount fastening | | O.K. | Loose | Retighten screws |
| Pedals | Check mount fastening | | O.K. | Loose | Retighten screws |
| Shifter | Check mount fastening | Functional check | O.K. | Loose | Retighten screws |
| Shift cables | Check for damage | Functional check | O.K. | Loose or defective | Adjust shift cables; new shift cables if necessary |
| Front derailleur | Check for damage | Functional check | O.K. | Gear shift difficult or not possible | Adjust |
| Rear derailleur | Check for damage | Functional check | O.K. | Gear shift difficult or not possible | Adjust |
| Electric drive | | | | | |
| Display | Check for damage | Functional check | O.K. | No screen display, defective screen display | Restart, test battery, new software, or new display; <i>take out of service</i> , |
| Electric drive control panel | Check for damage | Functional check | O.K. | No response | Restart; contact control panel manufacturer, new control panel |
| Tachometer | | Speed measurement | O.K. | Pedelec travelling 10% too fast/slow | Shut off pedelec until source of fault is found |
| Cabling | Visual inspection | | O.K. | Failure in system, damage, kinked cables | New cabling |
| Battery mount | Firmly in position, lock, contacts | Functional check | O.K. | Loose; lock doesn't close, no contacts | New battery mount |
| Motor | Visual inspection and mount | | O.K. | Damage, loose | Refasten motor, contact motor manufacturer, new motor |
| Software | Check version | | In latest version | Not latest version | Import update |

Technical inspection, checking safety, test ride

| Components | Description | | Criteria | | Measures if rejected |
|--|---------------------|------------------|--------------------|--|---|
| | Assembly/inspection | Tests | Acceptance | Rejection | |
| Brake system | | Functional check | O.K. | No full braking; braking distance too long | Locate defective part in brake system and correct |
| Gear shift under operating load | | Functional check | O.K. | Problems when shifting gear | Readjust gear shift |
| Suspension components (fork, shock absorber, seat post) | | Functional check | O.K. | Suspension too deep or no longer exists | Locate defective component and correct |
| Electric drive | | Functional check | O.K. | Loose connection, problems when riding, accelerate | Locate defective part in electric drive and correct |
| Light system | | Functional check | O.K. | No continuous light, too bright | Locate defective part in light system and correct |
| Test ride | | | No strange noises. | Strange noises. | Locate source of noise and correct |

| | |
|---|--|
| Date | |
| Fitter's name: | |
| Final inspection by workshop manager | |

11.3 Maintenance log

Diagnosis and documentation of current status

Date:

Frame number:

| Components | Frequency | Description | | | Criteria | | Measures if rejected |
|-----------------------------------|----------------------------------|---|---------------------|--|------------|--------------------------------|--|
| | | Inspection | Tests | Maintenance | Acceptance | Rejection | |
| Front wheel | 6 months | Assembly | | | O.K. | Loose | Adjust quick release |
| Kickstand | 6 months | Check mount fastening | Functional check | | O.K. | Loose | Retighten screws |
| Tyres | 6 months | | Tyre pressure check | | O.K. | Tyre pressure too low/too high | Adjust tyre pressure |
| Frame | 6 months | Check for damage – fracture, scratches | | | O.K. | Damage detected | Shut off pedelec; new frame |
| Handles, coverings | 6 months | Wear; check if fastened securely | | | O.K. | Not provided | Retighten screws, new handles or coverings as specified in parts list |
| Handlebars, stem | 6 months | Check mount fastening | | | O.K. | Loose | Retighten screws; new stem as specified in parts list if necessary |
| Steering headset | 6 months | Check for damage | Functional check | Lubricating and adjustment | O.K. | Loose | Retighten screws |
| Saddle | 6 months | Check mount fastening | | | O.K. | Loose | Retighten screws |
| Seat post | 6 months | Check mount fastening | | | O.K. | Loose | Retighten screws |
| Protective plate | 6 months | Check mount fastening | | | O.K. | Loose | Retighten screws |
| Pannier rack | 6 months | Check mount fastening | | | O.K. | Loose | Retighten screws |
| Attachments | 6 months | Check mount fastening | | | O.K. | Loose | Retighten screws |
| Bell | 6 months | | Functional check | | O.K. | No ring, too quiet, missing | New bell as specified in the parts list |
| Suspension elements | | | | | | | |
| Fork, suspension fork | To manufacturer's specifications | Check for damage – corrosion, fracture | | Maintenance as specified by manufacturer Lubrication, oil change as specified by manufacturer | O.K. | Damage detected | New fork as specified in the parts list |
| Rear frame damper | To manufacturer's specifications | Check for damage – corrosion, fracture | | Maintenance as specified by manufacturer Lubrication, oil change as specified by manufacturer | O.K. | Damage detected | New fork as specified in the parts list |
| Suspension seat post | To manufacturer's specifications | Check for damage | | Maintenance as specified by manufacturer | O.K. | Damage detected | New fork as specified in the parts list |
| Brake system | | | | | | | |
| Brake lever | 6 months | Check mount fastening | | | O.K. | Loose | Retighten screws |
| Brake fluid | 6 months | Check fluid level | | Depending on time of year | O.K. | Too little | Top up brake fluid; <i>take out of service</i> if damaged; new brake hoses |
| Brake linings | 6 months | Check brake linings, brake discs or rims for damage | | | O.K. | Damage detected | New brake linings, brake discs or rims |
| Back-pedal brake braking armature | 6 months | Check mount fastening | | | O.K. | Loose | Retighten screws |
| Brake system | 6 months | Check mount fastening | | Functional check | O.K. | Loose | Retighten screws |

| Components | Frequency | Description | | | Criteria | | Measures if rejected |
|---------------------------------|-----------|------------------------------------|-------------------|-------------|-------------------|---|---|
| | | Inspection | Tests | Maintenance | Acceptance | Rejection | |
| Light system | | | | | | | |
| Rechargeable battery | | First examination | | | O.K. | Error message | Contact battery manufacturer; <i>take out of service</i> , new battery |
| Light cabling | | Connections, correct wiring | | | O.K. | Cable defective, no light | New cabling |
| Rear light | | Side light | Functional check | | O.K. | No constant light | New rear light as specified in parts list; replace battery if necessary |
| Front light | | Side light, daytime riding light | Functional check | | O.K. | No constant light | New front light as specified in parts list; replace battery if necessary |
| Reflectors | | All complete, state, fastening | | | O.K. | Damaged or not all complete | New reflectors |
| Drive/gear shift | | | | | | | |
| Chain/cassette/pinion/chainring | | Check for damage | | | O.K. | Damage | Refasten if necessary or replace as specified in parts list |
| Chain guard/spoke guard | | Check for damage | | | O.K. | Damage | Replace as specified in parts list |
| Bottom bracket axle/crank | | Check mount fastening | | | O.K. | Loose | Retighten screws |
| Pedals | | Check mount fastening | | | O.K. | Loose | Retighten screws |
| Shifter | | Check mount fastening | Functional check | | O.K. | Loose | Retighten screws |
| Shift cables | | Check for damage | Functional check | | O.K. | Loose or defective | Adjust shift cables; new shift cables if necessary |
| Front derailleur | | Check for damage | Functional check | | O.K. | Gear shift difficult or not possible | Adjust |
| Rear derailleur | | Check for damage | Functional check | | O.K. | Gear shift difficult or not possible | Adjust |
| Electric drive | | | | | | | |
| Display | | Check for damage | Functional check | | O.K. | No screen display, defective screen display | Restart, test battery, new software, or new display; <i>take out of service</i> , |
| Electric drive control panel | | Check drive for damage | Functional check | | O.K. | No response | Restart; contact control panel manufacturer, new control panel |
| Tachometer | | | Speed measurement | | O.K. | Pedelec travelling 10% too fast/slow | Shut off pedelec until source of fault is found |
| Cabling | | Visual inspection | | | O.K. | Failure in system, damage, kinked cables | New cabling |
| Battery mount | | Firmly in position, lock, contacts | Functional check | | O.K. | Loose; lock doesn't close, no contacts | New battery mount |
| Motor | | Visual inspection and mount | | | O.K. | Damage, loose | Refasten motor, contact motor manufacturer, new motor; <i>take out of service</i> |
| Software | | Check version | | | In latest version | Not latest version | Import update |

Technical inspection, checking safety, test ride

| Components | Description | Criteria | | Measures if rejected |
|---|------------------|--------------------|--|---|
| Assembly/inspection | Tests | Accept- ance | Rejection | |
| Brake system | Functional check | O.K. | No full braking; braking distance too long | Locate defective part in brake system and correct |
| Gear shift under operating load | Functional check | O.K. | Problems when shifting gear | Readjust gear shift |
| Suspension components (fork, shock absorber, seat post) | Functional check | O.K. | Suspension too deep or no longer exists | Locate defective component and correct |
| Electric drive | Functional check | O.K. | Loose connection, problems when riding, accelerate | Locate defective part in electric drive and correct |
| Light system | Functional check | O.K. | No continuous light, too bright | Locate defective part in light system and correct |
| Test ride | | No strange noises. | Strange noises. | Locate source of noise and correct |

| | |
|--------------------------------------|--|
| Date | |
| Fitter's name: | |
| Final inspection by workshop manager | |

12 Keyword index

A

- Air chamber, 17
- Air valve
 - Fork, 16
 - Rear frame damper, 17
- Alternative equipment, 7, 100

B

- Back-pedal brake,
 - braking, 70
- Battery level indicator, 20
- Battery, 20
 - charging, 59
 - checking, 33
 - disposing of, 90
 - waking, 60
- Belt tension, 80
- Brake arm, 17
- Brake calliper, 18
- Brake disc, 18
- Brake lever, 25
 - adjusting the pressure point 46
- Brake lining, 17
 - maintaining, 79
- Brake,
 - using the transport securing system, 30
- Break in operation, 31, 34, 67
 - carrying out, 31
 - preparing, 31

C

- Chain drive, 19
- Chain guard,
 - checking, 56
- Chain tension, 80
- Chain wheel, 19
- Chain, 14, 19
 - maintaining, 80
- Charger,
 - disposing of, 90
- Clamping force,
 - Checking the quick releases, 35
 - Setting the quick releases, 35

D

- Direction of travel, 19
- Display, 20, 21, 26
 - attaching, 62
 - charging the battery, 61, 62, 63, 64, 67
 - removing, 63
- Drive system, 19
 - switching on, 61, 62

E

- EC Declaration of Conformity, 101

F

- Fork, 15
 - setting the compression damper, 72
- Fork end, 15
 - Setting the rebound damper, 71
 - structure, 16
- Frame, 14

- Front wheel brake, 17, 18
 - braking, 69
- Front wheel, see Wheel

G

- Gear shift twist grip,
 - checking, 79
- Gear shift,
 - maintaining, 79
 - switching, 72

H

- Handlebars, 14, 25
- Headlight, 19
- Hub, 15

I

- Initial commissioning 33

J

- Journey information, 26
 - resetting, 65
 - switching, 65

L

- Level of assistance, 26
 - selecting, 64
- ECO, 26
- SPORT, 26
- TOUR, 26
- TURBO, 26
- Lever, 17

M

- Minimum insertion depth marking, 44
- Model year, 8
- Motor, 19
- Mudguards,
 - checking, 56

O

- On-screen indicator, 19, 25, 55
- Operating status indicator, 20
- O-ring, 17

P

- Packaging, 32
- Pannier rack, 14
 - changing, 57
 - checking, 56
 - using, 57
- Pedal, 18, 19

Q

- Quick release, 15

R

- Rear frame damper,
 - structure, 17
- Rear light, 19
- Rear wheel brake, 18
- Riding light, 20, 26
 - checking function, 56
- Rim brake locking lever 18
- Rim, 15
 - checking, 78
- Roller brake,
 - braking, 70

S

- Saddle, 14
 - changing the saddle tilt, 43
 - changing the seat length, 45
 - determining the saddle height, 43, 45
- Seat post, 14
- Setting wheel, 17
- Shifter,
 - checking, 79
 - setting, 82
- Spoke, 15
- Suspension head, 15
- System message, 26
- System setting, 26
 - changing, 65
 - changeable, 26

T

- Transportation, 29
- Transporting, see Transportation
- Type number, 8
- Tyres, 15
 - checking, 78

U

- Using 73

V

- Valve, 15
 - Dunlop valve, 15

W

- Weight,
 - permitted total weight, 8
- Wheel,
 - maintaining, 78
- Winter break, see Break in operation

13 Glossary

Brake lever

Source: EN 15194:2017: lever used to apply the brake.

Braking distance

Source: EN 15194:2017: distance travelled by a pedelec between the commencement of braking and the point at which the pedelec comes to rest.

Cargo bike

Source: DIN 79010: bicycle mainly designed to carry goods.

CE marking

Source: Directive 2006/42/EC on Machinery: the manufacturer uses the CE marking to declare that the Pedelec complies with the applicable requirements.

City and trekking bicycles

Source: EN-ISO 4210 - 2: pedelec designed for use on public roads primarily for means of transportation or leisure.

Consumables

Source: EN 82079-1: any part or material that is necessary for continued use or maintenance of the product.

Decommissioning

Source: DIN 31051: intentional, unlimited interruption in an object's functional capability.

Disc brake

Source: EN 15194:2017: brake in which brake pads are used to grip the lateral faces of a thin disc attached to or incorporated in the wheel hub.

Drive belt

Source: EN 15194:2017: seamless ring belt which is used as a means of transmitting motive force.

Electrical control system

Source: EN 15194:2017: electronic and/or electrical component, or an assembly of components provided for installation into a vehicle, together with all electrical connections

and associated wiring for the motor electrical power assistance.

Electrically power assisted cycle, pedelec

Source: EN 15194:2017: electrically power assisted cycle, equipped with pedals and an auxiliary electric motor, which cannot be propelled exclusively by means of the auxiliary electric motor, except in start-up assistance mode.

Fault

Source: EN 13306:2018-02, 6.1: state of an item (4.2.1) characterized by inability to perform a required function (4.5.1), excluding the inability during preventive maintenance or other planned actions, or due to lack of external resources.

Folding bicycle

Source: EN-ISO 4210-2: bicycle designed to fold into a compact form, facilitating transport and storage.

Fork steerer

Source: EN 15194:2017: part of a fork that rotates about the steering axis of a bicycle frame head tube. It is normally connected to the fork crown or directly to the fork legs, and is normally the point of connection between the fork and the handlebar stem.

Fracture

Source: EN 15194:2017: unintentional separation into two or more parts.

Instruction handbook

Source: ISO/FDIS 20607:2018: part of the user information that machine manufacturers provide to machine operators; it contains guidance, instructions and tips related to the use of the machine in all its life cycle phases.

Maintenance

Source: DIN 31051: maintenance is generally performed at regular intervals and often carried out by trained technical staff. This ensures a maximum service life and low wear and tear for the maintained items. Proper maintenance is often also a pre-requisite for providing a warranty.

Maximum continuous power

Source: ZEG: the maximum continuous power is the maximum power for the electric motor output shaft during 30 minutes.

Maximum saddle height

Source: EN 15194:2017: vertical distance from the ground to the point where the top of the seat surface is intersected by the seat-post axis, measured with the saddle in a horizontal position and with the seat-post set to the minimum insertion-depth mark.

Maximum tyre pressure

Source: EN 15194:2017: maximum tyre pressure recommended by the tyre or rim manufacturer for a safe and efficient performance. If the rim and tyre both indicate a maximum tyre pressure, the maximum inflation pressure is the lower of the two pressures indicated.

Minimum insertion depth mark

Source: EN 15194:2017: mark indicating the minimum insertion-depth of handlebar stem into fork steerer (fork stem) or seat post into frame.

Model year

Source: ZEG: the model year refers to the first production year that the series-manufactured pedelec was manufactured in the version in question and is not always identical with the year of manufacture. The year of manufacture may be before the model year in some cases. If no technical modifications are introduced to the series, production may continue of pedelecs from a previous model year.

Mountain bike

Source: EN-ISO 4210-2: bicycle designed for use off-road on rough terrain, on public roads, and on public pathways, equipped with a suitably strengthened frame and other components, and, typically, with wide-section tyres with coarse tread patterns and a wide range of transmission gears.

Off-road rough terrain

Source: EN 15194:2017: coarse pebble tracks, forest trails, and other general off-road tracks where tree roots and rocks are likely to be encountered.

Permitted total weight

Source: EN 15194:2017: weight of the fully assembled pedelec plus the rider and baggage, as specified by the manufacturer.

Quick-release device, quick release

Source: EN 15194:2017: lever actuated mechanism that connects, retains or secures a wheel or any other component.

Racing bicycle

Source: EN-ISO 4210-2: bicycle intended for high-speed amateur use on public roads having a steering assembly with multiple grip positions allowing for an aerodynamic posture, a multi-speed transmission system, tyre width not greater than 28 mm and a maximum mass of 12 kg for the fully assembled bicycle.

Seat post

Source: EN 15194:2017: component that clamps the saddle (with a bolt or assembly) and connects it with the frame.

Shut-off speed

Source: EN 15194:2017: speed reached, by the pedelec, at the moment the current has dropped to zero or to the no load current value.

Spare part

Source: EN 13306:2018-02, 3.5: item intended to replace a corresponding item in order to retain or maintain the original required function of the item.

Suspension fork

Source: EN 15194:2017: front fork incorporating controlled, axial flexibility to reduce the transmission of road-shocks to the rider.

Suspension frame

Source: EN 15194:2017: frame incorporating controlled, vertical flexibility to reduce the transmission of road-shocks to the rider.

Type number

Source: ZEG: all pedelec models have an eight-digit type number which is used to specify the design model year, the type of pedelec and the version.

Wear

Source: DIN 31051: reduction in useful life (4.3.4), caused by chemical and/or physical processes.

Weight of ready-to-ride bicycle

Source: ZEG: the indicated weight for a ready-to-ride bicycle refers to the weight of a pedelec at the time of sale. The weight of each additional accessory must be added to this weight.

Wheel

Source: EN 15194:2017: assembly or combination of hub, spokes or disc, and rim, but excluding tyre assembly.

Work environment

Source: EN ISO 9000:2015: set of conditions under which work is performed

Year of manufacture

Source: ZEG: the year of manufacture is the year in which the Pedelec was manufactured. The production period is always from August to July of the following year

Young adult bicycle

Source: EN-ISO 4210-2: bicycle designed for use on public roads by a young adult whose weight is less than 40 kg, with maximum saddle height of 635 mm or more and less than 750 mm. (see ISO 4210).

13.1 Abbreviations

ABS anti-blocking system

ECP electronic cell protection

13.2 Simplified terms

The following terms are used for better legibility:

| Term | Meaning |
|------------------------|---------------------------------|
| Operating instructions | Original operating instructions |
| Motor | Drive motor, sub-system |

Table 42: Simplified terms

I. EC declaration of conformity

Translation of the original EC declaration of conformity

The manufacturer:

HERCULES GMBH
Longericher Straße 2
50739 Köln, Germany

hereby declares that the electrically power assisted bicycles of types:

20-Q-0055, 20-Q-0056,

Year of manufacture 2019 and year of manufacture 2020

comply with all applicable requirements of *Machinery Directive 2006/42/EC*.

Furthermore, the electrically power assisted bicycles comply with all applicable basic requirements of *Electromagnetic Compatibility Directive 2014/30/EU*.

The following standards were applied: *ISO/DIS 20607:2018* Safety of machinery – Instruction handbook – General drafting principle; *EN 15194:2018* Cycles – Electrically power assisted cycles – EPAC bicycles and *EN 11243:2016* Cycles – *Luggage carriers for bicycles – Requirements and test methods*.

Ms. Janine Otto (Technical Editor), c/o HERCULES GMBH, Longericher Straße 2, 50739 Köln, Germany, is authorised to compile the technical documentation.



Cologne, 07/08/2019

.....
Place, date and signature

Georg Honkomp

-Managing Director-