



# HERCULES

**IMPORTANT  
READ CAREFULLY BEFORE USE  
KEEP SAFE FOR LATER REFERENCE**

## TRANSLATION OF THE ORIGINAL OPERATING INSTRUCTIONS

**EN**

**ELECTRIC BICYCLES**

**Pasero, Alassio**

18-R-0001 | 18-R-0002 | 18-R-0003 | 18-R-0005

034-11421 • 1.0 • 11.10.2017

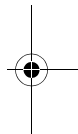
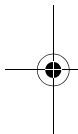

## Copyright

© HERCULES GMBH

Distribution or reproduction of these operating instructions and utilisation or communication of their content is prohibited unless expressly approved. Any infringement will render the offender liable for compensation. All rights reserved in the event that a patent, utility model or industrial design is registered.

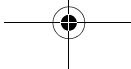

## Data sheet

Surname, first name of the purchaser:

---

Date of purchase:

---

Model:

---

Frame number:

---

Type number:

---

Unladen weight (kg):

---

Tyre size:

---

Recommended tyre pressure (bar)\*: front:                      rear:

---

Wheel circumference (mm):

---

Company stamp and signature:

\*After a tyre change, refer to the tyre markings for the permitted tyre pressures and make sure that they are observed. The recommended tyre pressure must not be exceeded.

## Technical data

**1 Technical data****Bicycle**

<b>Transportation temperature</b>	5 °C - 25 °C
<b>Ideal transportation temperature</b>	10 °C - 15 °C
<b>Storage temperature</b>	5 °C - 25 °C
<b>Ideal storage temperature</b>	10 °C - 15 °C
<b>Operation temperature</b>	5 °C - 35 °C
<b>Working environment temperature</b>	15 °C - 25 °C
<b>Charging temperature</b>	10 °C - 30 °C
<b>Power output/system</b>	250 W (0.25 W)
<b>Shut-off speed</b>	25 km/h

Table 1:

**Bicycle technical data****Battery**

<b>Transportation temperature</b>	5 °C - 25 °C
<b>Ideal transportation temperature</b>	10 °C - 15 °C
<b>Storage temperature</b>	5 °C - 25 °C
<b>Ideal storage temperature</b>	10 °C - 15 °C
<b>Charging ambient temperature</b>	10 °C - 30 °C

Table 2:

**Battery technical data**



Technical data

**Display**

<b>Internal lithium ion battery</b>	3.7 V, 240 mAh
<b>Storage temperature</b>	5 °C - 25 °C
<b>Charging ambient temperature</b>	10 °C - 30 °C

**Table 3:**

**Display technical data**

**Emissions**

<b>A-weighted emission sound pressure level</b>	< 70 dB(A)
<b>Total vibration level for the hands and arms</b>	< 2.5 m/s <sup>2</sup>
<b>Highest effective value of weighted acceleration for the entire body</b>	< 0.5 m/s <sup>2</sup>

**Table 4:**

**Emissions from the bicycle\***

\*The safety requirements as per Electromagnetic Compatibility Directive 2014/30/EU have been met. The bicycle and the charger can be used in residential areas without restriction.

**USB port**

<b>Charge voltage</b>	5 V
<b>Charging current</b>	max. 500 mA

**Table 5:**

**USB port technical data**

**Tightening torque**

<b>Axle nut tightening torque</b>	35 Nm - 40 Nm
<b>Handlebars clamping screw maximum tightening torque*</b>	5 Nm - 7 Nm

**Table 6:**

**Tightening torque values**

\*if there is no other data on the component

---

## Table of contents

---

<b>1</b>	<b>Technical data</b>	<b>2</b>
<b>2</b>	<b>About these instructions</b>	<b>8</b>
2.1	Manufacturer	8
2.2	Laws, standards and directives	9
2.3	Other valid documents	10
2.4	Subject to change	10
2.5	Language	10
2.6	Identifying	11
2.6.1	Operating instructions	11
2.6.2	Bicycle	11
2.7	For your safety	12
2.7.1	Instruction, training and customer service	12
2.7.2	Basic safety notes	13
2.7.3	Warnings	13
2.7.4	Safety markings	14
2.8	For your information	14
2.8.1	Instructions for actions	14
2.8.2	Information on the type plate	14
2.8.3	Language conventions	17
2.9	Type plate	19
<b>3</b>	<b>Safety</b>	<b>20</b>
3.1	Requirements for the rider	20
3.2	Proper use	20
3.2.1	City and trekking bicycle	21
3.3	Improper use	21
3.4	Personal protective equipment	21
3.5	Hazards for vulnerable groups	21
3.6	Duty of care	22
3.6.1	Rider	22
3.6.2	User	23
<b>4</b>	<b>Description</b>	<b>24</b>
4.1	Overview	24
4.2	Handlebars	25
4.3	Wheel and fork	26
4.3.1	Valve	26
4.3.2	Suspension	27
4.4	Brake system	28
4.5	Electric drive system	29
4.6	Drive system	29

## Table of contents

4.6.1	Battery	31
4.6.1.1	Operating and charge status indicator	34
4.6.2	Running light	34
4.6.3	Display	34
4.6.3.1	USB port	35
4.6.3.2	Displays	36
4.6.4	Command console	40
<b>5</b>	<b>Transportation, storage and assembly</b>	<b>41</b>
5.1	Transportation	41
5.2	Storing	43
5.2.1	Break in operation	43
5.2.1.1	Preparing a break in operation	44
5.2.1.2	Carrying out break in operation	44
5.3	Assembly	45
5.3.1	Unpacking	45
5.3.2	Scope of delivery	46
5.3.3	Commissioning	46
5.3.3.1	Checking the battery	48
5.4	Installing the wheels with quick release	49
<b>6</b>	<b>Adjusting the bicycle to the rider</b>	<b>50</b>
6.1	Adjusting the saddle	50
6.1.1	Determining the seat height	50
6.1.2	Clamp the seat post with the quick release	51
6.1.3	Adjusting the sitting position and saddle tilt	52
6.2	Setting the handlebars	52
6.3	Basic suspension setting	53
6.3.1	Adjusting the hardness of the spring elements	53
6.3.1.1	Adjusting the hardness of the steel suspension fork	53
6.3.1.2	Adjusting the hardness of the air suspension elements	54
6.3.1.3	Front wheel	54
6.4	Setting the grip distance of the brake lever	55
<b>7</b>	<b>Operation</b>	<b>56</b>
7.1	Before each ride	58
7.2	Using the kickstand	60
7.3	Using the pannier rack	61
7.4	Battery	63
7.4.1	Integrated battery	65
7.4.1.1	Removing the integrated battery	65
7.4.1.2	Inserting the integrated battery	66

## Table of contents

7.4.2	Down tube battery	66
7.4.2.1	Removing the down tube battery	66
7.4.2.2	Inserting the down tube battery	67
7.4.3	Saddle tube battery	67
7.4.3.1	Removing the saddle tube battery	67
7.4.3.2	Inserting the saddle tube battery	67
7.4.4	Charging the battery	68
7.4.5	Waking the battery	70
7.5	Electric drive system	71
7.5.1	Switching on the drive system	71
7.5.2	Switching off the drive system	71
7.6	Command console with display	72
7.6.1	Using the USB port	72
7.6.2	Removing and attaching the display	72
7.6.3	Using the pushing aid	74
7.6.4	Using the running light	75
7.6.5	Selecting the level of assistance	75
7.6.6	Switching journey information	75
7.6.7	Changing the system information	75
7.7	Gear shift	76
7.8	Brakes	77
7.8.1	Using the brake	78
7.9	Locking the front wheel suspension	79
<b>8</b>	<b>Maintenance</b>	<b>80</b>
8.1	Cleaning and servicing	81
8.1.1	Battery	81
8.1.2	Display	81
8.1.3	Basic cleaning and preservation	82
8.1.4	Chain	82
8.2	Maintenance	83
8.2.1	Wheel	83
8.2.2	Brake system	84
8.2.3	Electrical cables and brake cables	84
8.2.4	Gear shift	84
8.2.5	USB port	84
8.2.6	Chain tension	85
8.3	Service	86
8.4	Correcting and repairing	87
8.4.1	Using original parts only	87
8.4.2	Wheel quick release	88

## Table of contents

8.4.2.1	Clamping the quick release	89
8.4.3	Adjusting the tyre pressure	91
8.4.3.1	Dunlop valve	91
8.4.3.2	Presta valve	92
8.4.3.3	Schrader valve	93
8.4.4	Setting the gear shift	94
8.4.4.1	Cable-operated gear shift, single-cable	94
8.4.5	Offsetting brake lining wear	95
8.4.6	Replacing the lighting	95
8.4.7	Setting the lamp	95
8.4.8	Repair by the specialist dealer	95
8.4.9	The electric drive system of drive system does not start up	96
8.4.10	First aid for system messages	97
8.4.10.1	First aid	97
8.4.10.2	Specific error eradication	98
8.5	Accessories	99
8.5.1	Child seat	100
8.5.2	Bicycle trailer	102
<b>9</b>	<b>Recycling and disposal</b>	<b>103</b>
<b>10</b>	<b>EC declaration of conformity</b>	<b>105</b>
<b>12</b>	<b>Table of figures</b>	<b>106</b>
<b>13</b>	<b>Index</b>	<b>107</b>

About these instructions

## 2 About these instructions

Read these operating instructions before commissioning the bicycle in order to use all the functions correctly and safely. They are not a substitute for personal training by the supplying HERCULES specialist dealer. The operating instructions are a component part of the bicycle. Therefore, if it is re-sold at a later time, they must be handed over to the subsequent owner.

These operating instructions are mainly directed at the rider and user of the cycle. In general, they are technical laypersons.



Text passages which are directed expressly at specialist staff (e.g. bicycle mechanics), are clearly marked with a blue tool symbol.

Staff at all HERCULES specialist dealers have specialist training and qualifications, and are therefore capable of identifying risks and preventing hazards which may arise during maintenance, servicing and repairs on the bicycle. Information for specialist staff does not require technical laypersons to take any action.

### 2.1 Manufacturer

The manufacturer of the bicycle is:

HERCULES GMBH  
Longericher Straße 2  
50739 Köln, Germany

Tel.: +49 4471 18735 0  
Fax: +49 4471 18735 29  
E-mail: [info@hercules-bikes.de](mailto:info@hercules-bikes.de)  
Internet: [www.hercules-bikes.de](http://www.hercules-bikes.de)

## 2.2

### Laws, standards and directives

These operating instructions comply with the essential requirements from:

- the Machinery Directive 2006/42/EC,
- EN ISO 12100:2010 Safety of machinery – General principles of design – Risk assessment and reduction,
- EN ISO 4210-2:2015, Cycles – Safety requirements for bicycles – Part 2: Requirements for city and trekking, young adult, mountain and racing bicycles,
- EN 15194:2009+A1:2011 Cycles – Electrically power assisted cycles – EPAC bicycles,
- EN 11243:2016, Cycles – Luggage carriers for bicycles – Requirements and test methods,
- the Electromagnetic Compatibility Directive 2014/30/EU,
- EN 82079-1:2012, Preparation of instructions for use – Structuring, content and presentation – Part 1: General principles and detailed requirements,
- EN ISO 17100:2016-05, Translation Services – Requirements for translation service.



## About these instructions

---



### **2.3 Other valid documents**

These operating instructions are only complete in conjunction with the other valid documents.

The following document applies for this product:

- Charger operating instructions.

No other information is also applicable.

The constantly updated lists of approved accessories and parts are available to HERCULES specialist dealers.

### **2.4 Subject to change**

The information contained in these operating instructions are the approved technical specifications at the time of printing. Any significant changes are included in a new issue of the operating instructions.

### **2.5 Language**

The original operating instructions are written in German. A translation is not valid without the original operating instructions.





## 2.6 Identifying

### 2.6.1 Operating instructions

These operating instructions are printed in colour and glued (PUR glue) in an outer cover made of thin paper. HERCULES GMBH assumes no liability for copies of any kind, for example, black and white copies, loose pages or electronic copies.

The identification number of these operating instructions is made up of the document number, the version number and the release date. It can be found on the cover page and in the footer.

<b>Identification number</b>	034-11421_0.1_10.10.2017
------------------------------	--------------------------

Table 7:

**Identification number of the operating instructions**

### 2.6.2

#### Bicycle

These HERCULES operating instructions refer to the *model year* 2018. The production period is from August 2017 to June 2018. They are issued in August 2017.

The operating instructions are a component part of the following bicycles:

<b>Type no.</b>	<b>Model</b>	<b>Bicycle type</b>
18-Q-0029	PASERO	City and trekking bicycle
18-Q-0030	PASERO	City and trekking bicycle
18-Q-0098	PASERO	City and trekking bicycle
18-Q-0031	ALASSIO PRO 10	City and trekking bicycle
18-Q-0032	ALASSIO PRO 10	City and trekking bicycle
18-Q-0033	ALASSIO SPORT 9	City and trekking bicycle
18-Q-0034	ALASSIO SPORT 9	City and trekking bicycle
18-Q-0035	ALASSIO SPORT 9	City and trekking bicycle

Table 8:

**Type number, model and bicycle type categorisation**

## About these instructions

---

### 2.7

#### **For your safety**

The safety concept of the bicycle comprises four elements:

- the instruction of the rider and/or user, and maintenance and repair of the bicycle by the HERCULES specialist dealer,
- the chapter on general safety,
- the warnings in these instructions and
- the safety marking on the type plates.

#### 2.7.1

#### **Instruction, training and customer service**

The HERCULES specialist dealer and supplier provides customer service. Contact details can be found on the back page of these operating instructions and in the data sheet. If you are unable to contact your specialist dealer, you will find further HERCULES specialist dealers on [www.hercules-bikes.de](http://www.hercules-bikes.de). They will also be able to attend to your customer service needs.



The HERCULES specialist dealer commissioned to perform repairs and maintenance work receives regular training.

The rider or the user of the bicycle will be instructed in person on the functions of the bicycle, in particular its electrical functions and correct use of the charger, at the latest when the bicycle is handed over by the supplying HERCULES specialist dealer.





Each rider to whom this bicycle is made available, must receive instruction on the functions of the bicycle. The operating instructions must be submitted to each rider in printed form and must be acknowledged and adhered to.

## 2.7.2 Basic safety notes

These operating instructions have a chapter with general safety notes [[▷ Chapter 3, page 20](#)]. The chapter stands out because of its grey background.

## 2.7.3 Warnings

Hazardous situations and actions are marked with warnings. The warnings in these operating instructions are shown as follows:

SIGNAL WORD	Type and source of the danger
	Description of the danger and the consequences.
	► Measures
	The following pictograms and signal words are used in the operating instructions for warnings and information notices:
	Will lead to serious or even fatal injuries if ignored. High-risk hazard.
	May lead to serious or even fatal injuries if ignored. Medium-risk hazard.
	May lead to minor or moderate injuries. Low-risk hazard.
	May lead to material damage if ignored.

**Table 9:** Meanings of the signal words

## About these instructions

---

### 2.7.4 Safety markings

The following safety markings are used on the type plates of the bicycle:

---



General warning



Adhere to the instructions for use

---

Table 10:

### Safety markings on the product

## 2.8 For your information

### 2.8.1 Instructions for actions

Instructions for actions are structured in accordance with the following pattern:

- ✓ Requirements (optional)
- ▶ Instruction for action
- ⇒ Result of the action (optional)

### 2.8.2 Information on the type plate

Alongside the warnings, the type plates of the products also contain other important information on the bicycle:

About these instructions





 <b>1</b>	only suitable for the road, no off-road riding or jumps
 <b>2</b>	suitable for roads, off-road riding and jumps of up to 15 cm
 <b>3</b>	suitable for rough off-road riding and jumps of up to 61 cm
 <b>4</b>	suitable for rough off-road riding and jumps of up to 122 cm
 <b>5</b>	suitable for the most difficult terrain

Table 11:

Area of use







	City and trekking bicycle
	Child's bicycle / bicycle for young adults
	BMX bicycle
	Mountain bike
	Racing bicycle
	Carrier bicycle
	Folding bicycle

Table 12:

Bicycle type

## About these instructions

---



Read the instructions



Separate collection of electrical and electronic devices



Separate collection of batteries



Must not be thrown into fire (burning prohibited)



Must not be thrown into water (immersed)



Device of protection class II



Only suitable for use indoors



Fuse (device fuse)



EU conformity



Recyclable material

Table 13:

---

Information on the type plate

### 2.8.3 Language conventions

The bicycle described in these operating instructions may be equipped with alternative components. The equipment of the bicycle is defined by the respective type number. If applicable, the notes *alternative equipment* and *alternative version* make reference to the use of alternative components.

*Alternative equipment* describes additional components which are not necessarily an integral part of every bicycle in these instructions.

*Alternative version* explains the various variants of components if they differ in use.

The following terms are used for better legibility:

Term	Meaning
Operating instructions	Original operating instructions or translation of the original operating instructions
Bicycle	Electric motor driven cycle
Motor	Drive motor

**Table 14:** Simplified terms

## About these instructions

---

The following conventions are used in these operating instructions:

<b>Convention</b>	<b>Use</b>
<i>Italics</i>	Entry in the index
SPACED	Displays on the <i>display screen</i>
[▷ <i>Example, page numbering</i> ]	Cross references
•	Bulleted lists

---

**Table 15:**

**Conventions**



## 2.9 Type plate

The type plate is situated on the *frame*. The type plate features the following information:

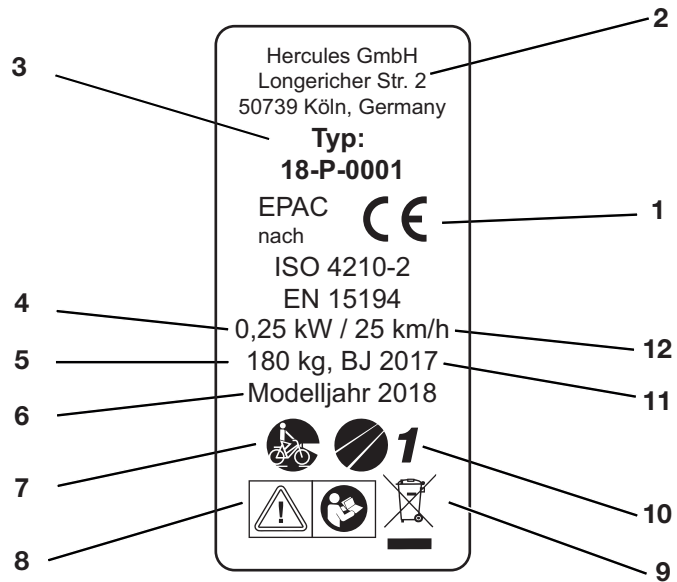

Figure 1:

### Type plate, example

- 1 CE marking
- 2 Manufacturer
- 3 Type number
- 4 Maximum power output
- 5 Permitted total weight
- 6 Model year
- 7 *Bicycle type*
- 8 *Safety notes*
- 9 *Disposal information*
- 10 *Area of use*
- 11 Year of manufacture
- 12 Shut-off speed

## Safety

### 3

## Safety

#### 3.1

### Requirements for the rider

If there are no legal requirements for the rider of electrically power assisted cycles, we recommend that the rider should be a minimum 15 years of age and have experience with muscle-powered bicycles.

The physical and mental abilities of the rider must be sufficient for the use of a muscle-powered bicycle.

If the bicycle is used by minors, as well as thorough instruction to be provided by or in the presence of the legal guardians, supervised use should also be scheduled until there is certainty that the bicycle is being used in accordance with these operating instructions. The legal guardians hold sole responsibility for determining whether minors are suitable to use the bicycle.

#### 3.2

### Proper use

The bicycle must only be used in perfect, fully functional condition. National requirements may apply to the bicycle which differ from the standard equipment. For riding on public roads, some special regulations apply in relation to *running light*, *reflectors* and other components.

The general laws and the regulations for the prevention of accidents and environmental protection in the respective country of use must be adhered to. Proper use also includes all instructions for actions and check lists in these operating instructions. Approved accessories can be installed by specialist staff.

Each bicycle is assigned to a *bicycle type* which determines the proper use.

### 3.2.1



#### City and trekking bicycle

City and trekking bicycles are designed for daily, comfortable use on asphalted roads and paths. They are suitable for riding on public roads.

City and trekking bicycles are not sports bicycles. If used for sports, reduced riding stability and diminished comfort are to be expected. City and trekking bicycles are not suitable for riding off-road.

### 3.3

#### Improper use

Failure to adhere to the proper use causes a risk of personal injury and material damage. The bicycle is not suitable for the following uses:

- riding with a damaged or incomplete bicycle,
- riding over steps,
- riding through deep water,
- lending the bicycle to untrained riders,
- carrying further passengers,
- riding with excessive luggage,
- riding with no hands,
- riding on ice and snow,
- improper servicing,
- improper repair,
- demanding areas of use, such as professional competition, and
- stunt riding or acrobatics.

### 3.4

#### Personal protective equipment

We recommend that you wear a suitable safety helmet. We also recommend that you wear typical, close-fitting cycling clothing and sturdy footwear.

### 3.5

#### Hazards for vulnerable groups

The battery and the charger must be kept out of the reach of children.

## Safety

---

### 3.6

#### Duty of care

The safety of the bicycle can only be assured if all the necessary measures are taken.

#### 3.6.1

##### Rider

The rider:

- receives instruction before the first ride. He/she can clarify any questions relating to the operating instructions with the user or the HERCULES specialist dealer.
- wears personal protective equipment.
- assumes all the obligations of the user in case the bicycle changes hands.

### 3.6.2

#### User

The user has the duty of care and responsibility for scheduling these measures and checking that they are implemented.

The user:

- makes these operating instructions available to the rider for the duration of use of the bicycle. If necessary, he translates the operating instructions into a language which the rider understands.
- familiarises the rider with the functions of the bicycle before the first ride. Only riders who have received instruction must be allowed to ride the bicycle.
- instructs the rider on proper use and the wearing of personal protective equipment.
- employs specialist staff only for maintenance and repair of the bicycle.

The printed EC declaration of conformity in the appendix is valid as long as the bicycle remains in original condition. As soon as the user makes any relevant modifications or additions, he legally becomes the manufacturer. He must independently guarantee compliance with the EC directives again in order to:

- circulate the bicycle again,
- apply the CE marking and
- avoid compromising occupational safety.

Description

## 4 Description

### 4.1 Overview

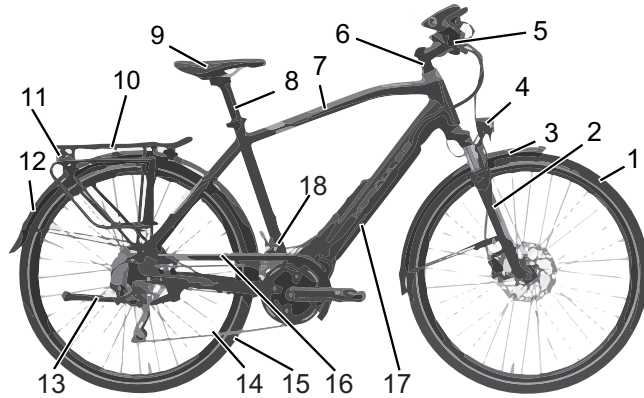

**Figure 2:** Bicycle, viewed from the right, example of Pasero

- 1 *Front wheel*
- 2 *Fork*
- 3 *Front mudguard*
- 4 *Lamp*
- 5 *Handlebars*
- 6 *Stem*
- 7 *Frame*
- 8 *Seat post*
- 9 *Saddle*
- 10 *Pannier rack*
- 11 *Rear light and reflector*
- 12 *Rear mudguard*
- 13 *Kickstand*
- 14 *Chain*
- 15 *Rear wheel*
- 16 *Chain guard*
- 17 *Battery*
- 18 *Frame number and type plate*

## 4.2 Handlebars

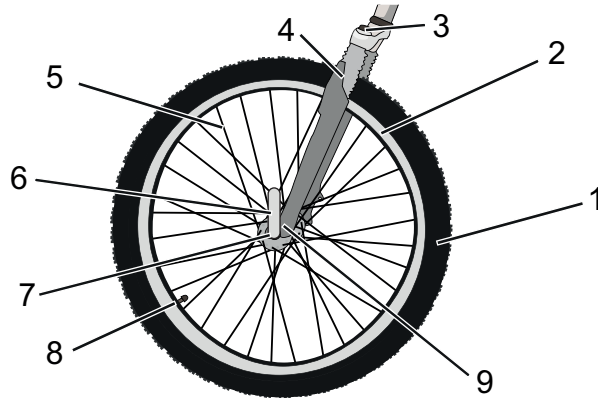

Figure 3:

Detailed view of bicycle from rider position, example

- 1 Rear brake lever
- 2 Bell
- 3 Lamp
- 4 Front brake lever
- 5 Front derailleur shifter
- 6 *Command console*
- 7 Display
- 8 Fork lock on *suspension fork head*
- 9 Rear derailleur shifter

## Description

**4.3 Wheel and fork**

**Figure 4:** Components of the wheel, example of front wheel

- |   |   |
|---|---|
| 1 | Tyre                                    |
| 2 | Rim                                     |
| 3 | Suspension fork head with setting wheel |
| 4 | Shock absorber                          |
| 5 | Spoke                                   |
| 6 | Quick release                           |
| 7 | Hub                                     |
| 8 | Valve                                   |
| 9 | Fork end of the shock absorber          |

**4.3.1 Valve**

Each wheel has a valve. It is used to fill the *tyre* with air. There is a valve cap on each valve. The screw-on valve cap keeps out dust and dirt.

The bicycle either has a classical *Dunlop valve*, a *Presta valve* or a *Schrader valve*.



### 4.3.2

## Suspension

A suspension fork improves the floor contact and the comfort by providing suspension.

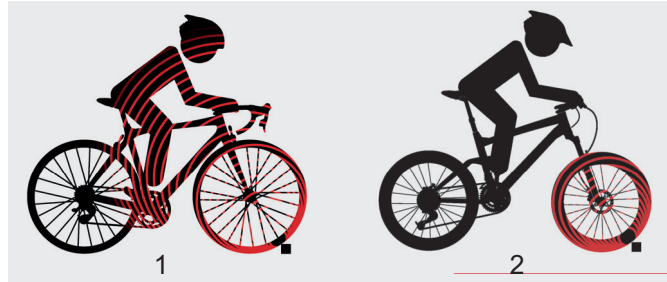

Figure 5:

**Bicycle without suspension (1) and with suspension (2) when riding over an obstacle**

The suspension prevents an impact, e.g. caused by a stone lying in the way, from being directed directly into the rider's body via a fork. Instead, it is absorbed by the suspension system. This causes the suspension fork to compress. The compression can be disabled so that a suspension fork reacts like a rigid fork.

## Description

**4.4 Brake system**

The bicycle is equipped with a disk brake.

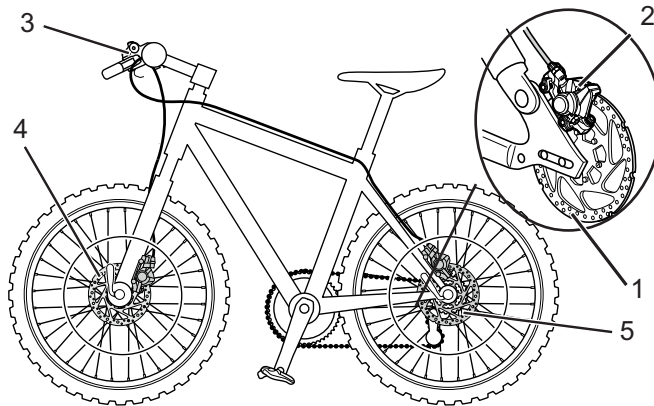

**Figure 6:** Bicycle brake system with a disk brake, example

- 1 Brake disk
- 2 Brake caliper with brake linings
- 3 *Handlebars with brake levers*
- 4 Front wheel brake disk
- 5 Rear wheel brake disk

On a bicycle with a disk brake, the brake disk is screwed permanently to the *hub* of the wheel. If the brake lever is pulled, the brake linings are pressed against the brake disk, and the movement of the wheel is stopped.

## 4.5 Electric drive system

## 4.6 Drive system

The bicycle is driven by muscle power via the chain drive. The force which is applied by pedalling in the direction of travel, drives the front chain wheel. The chain transmits the force onto the rear chain wheel and then onto the rear wheel.

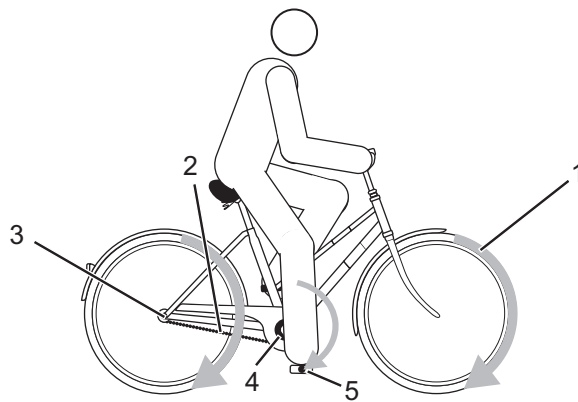

Figure 7:

Diagram of drive system

- 1 Direction of travel
- 2 Chain
- 3 Rear chain wheel
- 4 Front chain wheel
- 5 Pedal

The bicycle also has an integrated, electric drive system. The electric drive system is made of up to 8 components:

## Description

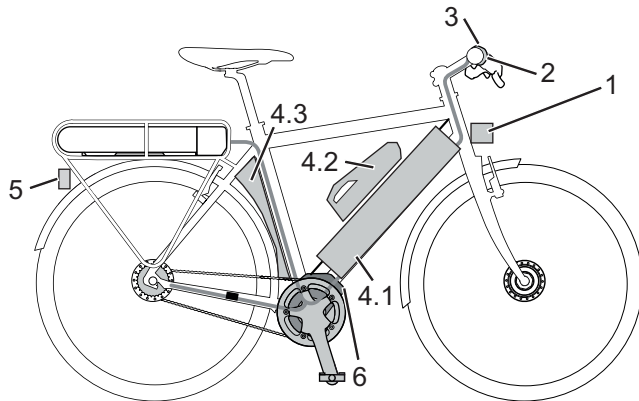

**Figure 8:** Diagram of electric drive system

- 1 *Lamp*
- 2 *Display*
- 3 *Command console*
- 4.1 *Integrated battery*
- 4.2 *Down tube battery*
- 4.3 *Seat tube battery*
- 5 *Rear light*
- 6 *Motor*
- a charger which is designed for this battery.

As soon as the required muscle power from the rider pedalling passes a certain level, the motor is activated gently and assists the pedalling motion of the rider. The motor force is determined by the set level of assistance.

The bicycle does not have a separate emergency stop or emergency shut-off button. The drive system can be stopped in case of emergency by removing the *display*.

The motor switches off automatically as soon as the rider no longer pedals, the temperature is outside the permitted range, there is an overload or the shut-off speed of 25 km/h has been reached.

---

## Description

---

A pushing aid can be activated. The pushing aid continues to drive the bicycle at a slow speed as long as the rider pushes the **pushing aid button** on the *handlebars*. The maximum speed can be 6 km/h here. The drive stops when the **pushing aid button** is released.

### 4.6.1

#### Battery

The lithium ion battery has an internal electronic protection circuit. It is matched to the charger and the bicycle. The temperature of the battery is monitored constantly. The battery is safeguarded against deep discharge, overcharging, overheating and short circuit. In case of a risk the battery is switched off automatically by a protective circuit. The battery also switches to sleep mode for self-protection when not used for a longer period.

The service life of the battery can be extended if it is well cared for and, above all, stored at the correct temperatures. Even if the battery is cared for properly, the charge status of the battery reduces as it ages. If the operating time is severely shortened after charging, this is a sign that the battery is spent.

Description

<b>Transportation temperature</b>	5 °C - 25 °C
<b>Ideal transportation temperature</b>	10 °C - 15 °C
<b>Storage temperature</b>	5 °C - 25 °C
<b>Ideal storage temperature</b>	10 °C - 15 °C
<b>Charging ambient temperature</b>	10 °C - 30 °C

**Table 16:** Battery technical data

The bicycle has either an integrated battery, a down tube battery or a seat tube battery.

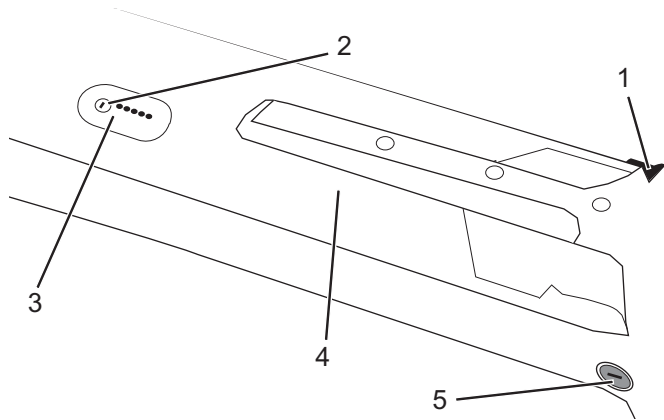

**Figure 9:** Integrated battery details

- 1 Retainer guard
- 2 On-Off switch
- 3 Operating and charge status indicator
- 4 Top of down tube
- 5 Battery lock

Description

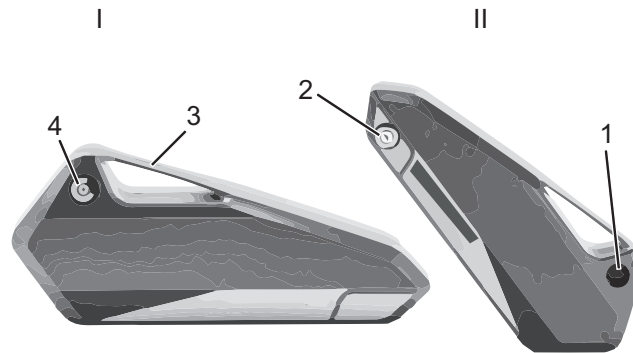

**Figure 10:** Details of the down tube battery from the right (I) and left (II)

- 1 Port for charger plug
- 2 Battery lock
- 3 Handle
- 4 Operating and charge status indicator with On-Off button (battery)

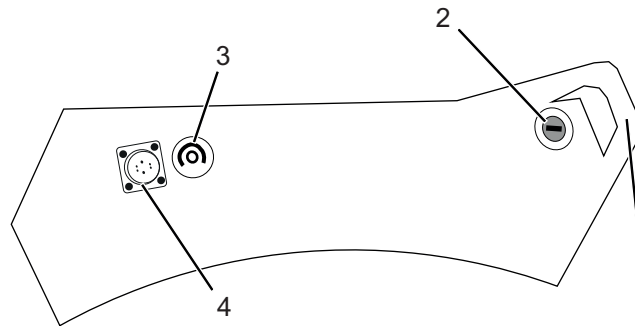

**Figure 11:** Seat tube battery details

- 1 Handle
- 2 Battery lock
- 3 Operating and charge status indicator with On-Off button (battery)
- 4 Port for charger plug

## Description

### 4.6.1.1

#### Operating and charge status indicator

The five green LEDs of the operating and charge status indicator indicate the charge status of the battery when the battery is switched on. Each LED represents 20% of the charge status. The charge status of the activated battery is also shown on the *display*.

If the charge status of the battery is below 5%, all the LEDs of the operating and charge status indicator go out. However, the charge status is still shown on the *display*.

### 4.6.2

#### Running light

When the running light is activated, the *lamp* and the rear light are switched on.

### 4.6.3

#### Display

The display controls the drive system with the operating elements and displays the journey data.

The bicycle's battery supplies the display with energy when the display is inserted in the mount, a sufficiently charged battery is inserted on the bicycle, and the drive system is switched on.

<b>Internal lithium ion battery</b>	3.7 V, 240 mAh
<b>Storage temperature</b>	5 °C - 25 °C
<b>Charging ambient temperature</b>	10 °C - 30 °C

Table 17:

#### Display technical data

The *display* has a USB port.



Description



Figure 12:

Display details

Use	
1	Display
2	USB port

Table 18:

Display overview

4.6.3.1

USB port

There is a USB port underneath the rubber cover on the lower edge of the *display*.

Charge voltage	5 V
Charging current	max. 500 mA

Table 19:

USB port technical data

Description

**4.6.3.2 Displays**

The *display* has 10 different displays:



**Figure 13: Overview of the displays**

Use	
1	Function display
2	Level of assistance
3	Unit of measure for speed
4	Display of rider's power output
5	Warning symbol
6	Running light symbol
7	Pushing aid symbol
8	Battery status indicator
9	Display of motor's power output
10	Current speed

**Table 20: Overview of the screen display**

## Description

**Level of assistance**

The higher the selected level for assistance, the more the drive system assists the rider when pedalling. The following levels of assistance are available.





Display	Level of assistance
	off
	1
	2
	3
	4

Table 21:

**Display of levels of assistance****Current speed**

In the system settings, you can select whether the speed is displayed in kilometres or miles.

**Function display**

The function display shows three different items of information:

- Journey information,
- System settings and data, and
- System messages.

## Description

### Journey information

Depending on the type of bicycle, the function display may show up to seven items of journey information. The displayed journey information can be switched.

Display	Function
CLOCK	Current time, displayed in hh:mm
TRIP DISTANCE	Distance travelled since the last reset, displayed in kilometres or miles
TRIP CALORIES	Calories burned since the last reset, displayed in calories
TRIP TIME	Time elapsed since the last reset, displayed in hh:mm
AVG. SPEED	Average speed since the last reset, displayed in kilometres per hour or miles per hour
MAX. SPEED	Maximum speed travelled since the last reset, displayed in kilometres per hour or miles per hour
TOTAL DISTANCE	Total distance travelled, displayed in kilometres or miles
TOTAL TIME	Travelled time, displayed in hh:mm

Table 22:

### Journey information

### System settings and data

In order to see the system settings, the rider has to call up the system settings. The rider can change the values of the system settings.

Display	Function
RESET TRIP	Reset all TRIP data
RESET ALL	Reset all data
<b>Light:</b>	
AUTO	The running light is switched on and off automatically based on the lighting conditions.
MANUAL	The running light is controlled manually.
ALWAYS ON	The running light is always on.
DATE	
TIME FORMAT	Displays the time either in the 24-hour or 12-hour format.
UNITS OF MEASURE	The units of measure are switched between kilometres and miles.

Table 23:

### Changeable system settings



Description



---

**System message**

The drive system monitors itself continuously and if an error is detected, it is indicated by a system message. The system may switch off automatically depending on the type of error. There is a table of system messages in the Appendix.

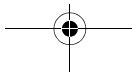
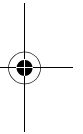
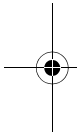

Description

**4.6.4 Command console**

The command console has six buttons.

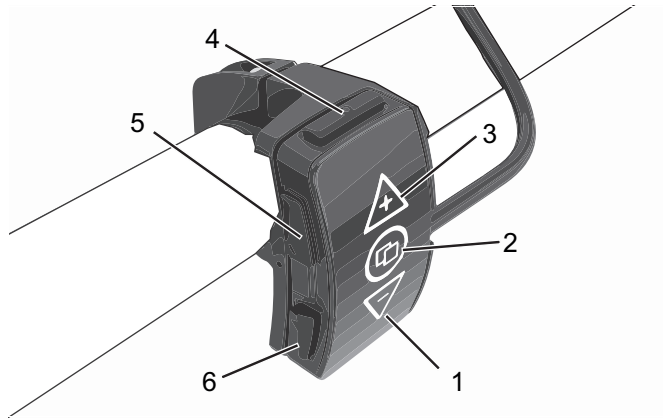

**Figure 14:** Overview of the command console

	Symbol	Surname
1	–	Minus button
2		Info button
3	+	Plus button
4		On-Off button
5		Running light button
6		Pushing aid button

**Table 24:** Overview of the command console

## 5 Transportation, storage and assembly

### 5.1 Transportation



#### Crash caused by unintentional activation

There is a risk of injury if the drive system is activated unintentionally.

- ▶ Remove the battery before the bicycle is transported.



#### Risk of fire and explosion due to high temperatures

Excessively high temperatures damage the batteries. The batteries may self-ignite and explode.

- ▶ Never expose the battery to sustained direct sunlight.

#### NOTICE

If the bicycle is lying flat, oil and grease may leak from the bicycle.

If the shipping carton with a bicycle is lying flat or on one end, it does not provide sufficient protection from damage to the *frame* and the wheels.

- ▶ Only transport the bicycle in an upright position.

#### NOTICE

Bicycle rack systems which secure the bicycle standing on its head by the *handlebars* or *frame*, generate inadmissible forces on the components during transportation. This can cause the supporting parts to break.

- ▶ Never use bicycle rack systems which secure the bicycle standing on its head by the *handlebars* or *frame*.

## Transportation, storage and assembly

---

- ▶ Take into account the weight of the roadworthy bicycle when transporting it.
- ▶ Remove the *display* and the battery before transportation of the bicycle.
- ▶ Protect the electrical components and connections on the bicycle from the elements with suitable protective covers.
- ▶ Remove accessories, for example drinking bottles, before transportation of the bicycle.
- ▶ When transporting by car, you must use a suitable bicycle rack system.



---

The HERCULES specialist dealer will advise you on how to select a suitable rack system properly and how to use it safely.

---

- ▶ Transport the bicycle in a dry, clean place which is protected from direct sunlight.



---

For shipping the bicycle, we recommend that you have the bicycle partially dismantled in the proper manner and packaged by the HERCULES specialist dealer.

---



**5.2****Storing****Risk of fire and explosion due to high temperatures**

Excessively high temperatures damage the battery. The battery may self-ignite and explode.

- ▶ Never expose the battery to sustained direct sunlight.

**NOTICE**

If the bicycle is lying flat, oil and grease may leak from the bicycle.

If the shipping carton with a bicycle is lying flat or on one end, it does not provide sufficient protection from damage to the *frame* and the wheels.

- ▶ Only store the bicycle in an upright position.
- ✓ Store the bicycle, battery and charger in a dry and clean place.

<b>Storage temperature</b>	5 °C - 25 °C
<b>Ideal storage temperature</b>	10 °C - 15 °C

Table 25:

**Storage temperature for the battery, the bicycle and the charger**

**5.2.1****Break in operation****NOTICE**

The battery discharges when it is not used. This can cause damage to the battery.

- ▶ The battery has to be recharged every 8 weeks.

**NOTICE**

The battery may become damaged if it is connected permanently to the charger.

- ▶ Do not connect the battery to the charger permanently.

If the bicycle is to be removed from service for longer than four weeks, e.g. in winter, a break in operation has to be prepared.

## Transportation, storage and assembly

---

### 5.2.1.1

#### Preparing a break in operation

- ✓ Remove the battery from the bicycle.
- ✓ Charge the battery to around 60% (three to four LEDs of the charge status indicator light up).
- ✓ The bicycle has to be cleaned with a damp cloth and preserved with wax spray. Never wax the friction surfaces of the brake.
- ✓ Before longer periods without use, it is recommendable for the HERCULES specialist dealer to carry out servicing, basic cleaning and apply preservative agent.

### 5.2.1.2

#### Carrying out break in operation

- ▶ Store the bicycle, battery and charger in a dry and clean environment.
- ▶ Check the charge status of the battery after 8 weeks. If only one LED of the charge status indicator lights up, recharge the battery to around 60%.

## Transportation, storage and assembly

**5.3****Assembly****Crushing caused by unintentional activation**

There is a risk of injury if the drive system is activated unintentionally.

- ▶ Remove the battery if the battery is not absolutely necessary for assembly.



- ✓ Assemble the bicycle in a clean and dry environment.
- ✓ The working environment should have a temperature of 15 °C - 25 °C.

**Working environment temperature** 15 °C - 25 °C

Table 26:

**Working environment temperature**

- ✓ If a fitting stand is used, it must be approved for a maximum weight of 30 kg.
- ✓ To reduce the weight, we recommend that you always disconnect the battery from the bicycle for the duration of use of the fitting stand.
- ✓ Universal tools, a torque spanner with an operating range of 5 Nm to 40 Nm and the special tools, as recommended by HERCULES GMBH, must be available.

**5.3.1****Unpacking****Hand injuries caused by cardboard packaging**

The shipping carton is closed with metal staples. There is a risk of puncture wounds and cuts when unpacking and crushing the packaging.

- ▶ Wear suitable hand protection.
- ▶ Remove the metal staples with pliers before the shipping carton is opened.

The packaging material consists mainly of cardboard and plastic film.

## Transportation, storage and assembly

- ▶ The packaging has to be disposed of in accordance with the regulations of the authorities.

### 5.3.2

#### Scope of delivery

The bicycle was completely assembled in the factory for test purposes and then dismantled for transportation.

The scope of delivery includes:

- the bicycle, 98% pre-assembled,
- the front wheel,
- the battery or batteries,
- the charger,
- the pedals,
- the operating instructions.

### 5.3.3

#### Commissioning



#### Fire and explosion caused by incorrect charger

Batteries which are charged with an unsuitable charger, may become internally damaged. This may result in fire or an explosion.

- ▶ Only ever use the battery with the supplied charger.
- ▶ To prevent mix-ups, mark the supplied charger and these operating instructions clearly, for example with the *frame number* or *type number* of the bicycle.

Given that initial commissioning of the bicycle requires special tools and specialist knowledge, it must be performed by trained specialist staff only.

Experience has shown that a bicycle which has not yet been sold, is spontaneously handed to consumers as soon as it appears ready to ride.

- ▶ Every bicycle must be prepared so that it is in fully usable condition immediately after being set up.

## Transportation, storage and assembly

Initial commissioning includes the following work:

- ▶ Check the battery [[▷ Chapter 5.3.3.1, page 48](#)].
- ▶ The battery is supplied partially charged. In order to guarantee full power, charge the battery fully.
- ▶ Install the *wheels with quick release* and the *pedals*.
- ▶ Move the *handlebars* and *saddle* into the functional position.
- ▶ Check all the components to make sure that they are firmly in place.
- ▶ Check all the settings and the tightening torque of the axle nuts.

**Axle nut tightening torque**

35 Nm - 40 Nm

**Table 27:**

**Axle nut tightening torque**

- ▶ Check the entire cable harness to make sure that it is routed properly:
  - You must prevent the cable harness from coming into contact with moving parts.
  - The cable routes must be smooth and free from sharp edges.
  - Moving parts must not apply any pressure or tension to the cable harness.
- ▶ Set the *lamp*.
- ▶ Check the drive system, the light equipment and the brakes to make sure that they are fully functional and effective.
- ▶ Set the drive system has to the national language and the appropriate system of measurement.
- ▶ Check the software version of the drive system and update it as necessary.

## Transportation, storage and assembly

### Sale of the bicycle

- ▶ Fill out the data sheet on the first page of the operating instructions.
- ▶ Adjust the bicycle to the rider.
- ▶ Set the *kickstand* and the *shifter*, and show the purchaser the settings.
- ▶ Instruct the user or rider how to use all the functions of the bicycle.

#### 5.3.3.1

### Checking the battery

The battery has to be checked before it is charged for the first time.

- ▶ Press the *On-Off button (battery)*.
- ⇒ If none of the LEDs on the operating and charge status indicator light up, the battery may be damaged.
- ⇒ If at least one of the LEDs of the operating and charge status indicator lights up, but not all of them, the battery can be charged.
- ▶ Once the battery has been charged, insert the battery on the bicycle.
- ⇒ Confirm, that the battery is an original Shimano battery or a BMZ battery.

**5.4****Installing the wheels with quick release****CAUTION****Crash caused by unfastened quick release**

A faulty or incorrectly installed quick release may become caught in the brake disk and block the wheel. This will cause a crash.

- ▶ Install the front wheel quick release lever on the opposite side to the brake disk.

**CAUTION****Crash caused by faulty or incorrectly installed quick release**

The brake disk becomes very hot during operation. Parts of the quick release may become damaged as a result. The quick release comes loose. This will result in a crash and injuries.

- ▶ The front wheel quick release lever and the brake disk must be situated on opposite sides.

**CAUTION****Crash caused by incorrectly set clamping force**

Excessively high clamping force will damage the quick release and cause it to lose its function.

Insufficient clamping force will cause a detrimental transmission of force. The suspension fork or the frame may break. This will result in a crash and injuries.

- ▶ Never fasten a quick release using a tool (e.g. hammer or pliers).
- ▶ Only use the clamping lever with the specified set clamping force.
- ▶ Open the clamping lever.
- ▶ Push the opened clamping lever with the wheel axle from the right-hand side through the hub.
- ▶ Clamp the wheel and set the clamping force, depending on the version.

## Adjusting the bicycle to the rider

# 6 Adjusting the bicycle to the rider



The HERCULES specialist dealer checks all the factory settings and, when the bicycle is sold, adapts the settings of the *saddle*, *handlebars*, *suspension fork* and the *spring damper elements* to the rider.

## 6.1 Adjusting the saddle

### 6.1.1 Determining the seat height



#### Crash caused by an excessively high seat post setting

A *seat post* which is set too high will cause the *seat post* or the *frame* to break. This will result in a crash and injuries.

- ▶ Do not pull the seat post out of the frame beyond the minimum insertion depth marking.

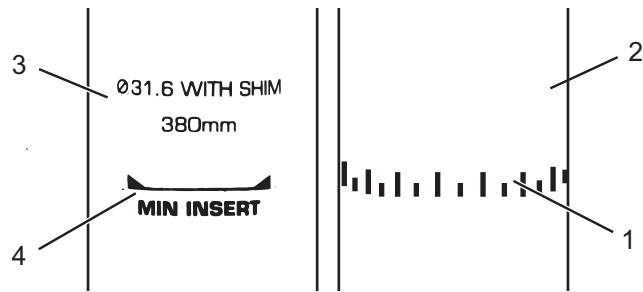

Figure 15:

Detailed view of the seat post, examples of the minimum insertion depth marking

- 1 III marking for minimum insertion depth
- 2 Seat post I
- 3 Seat post II
- 4 MIN marking for minimum insertion depth



## Adjusting the bicycle to the rider

From an ergonomic point of view, the seat height should be set so that the heel touches the lowest point of the pedal when the leg is outstretched.

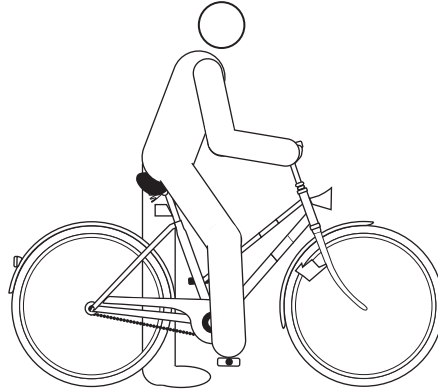

**Figure 16:** Determining the saddle height

### 6.1.2



### Clamp the seat post with the quick release

The HERCULES specialist dealer demonstrates the function of the quick release to the rider or user.



**Figure 17:** Seat post quick release in the final position

- 1 Seat post clamping lever
- 2 Seat post
- 3 Knurled nut

## Adjusting the bicycle to the rider

### Clamping

- ✓ Only clamp the *seat post* when the bicycle is stationary.

The *seat post clamping lever* is not marked with any lettering. You can tell whether it is open or closed from its shape.

- To close it, push the *seat post clamping lever* as far as it will go into the *seat post*.
- To open it, pull the *seat post clamping lever* away from the *seat post*.

► Check the *clamping force of the quick releases*.

### 6.1.3



### Adjusting the sitting position and saddle tilt

Special tools are required to adjust the seat length and the saddle tilt. The HERCULES specialist dealer adjusts the saddle setting to the rider.

### 6.2



### Setting the handlebars

- ✓ The handlebars setting must only be made while the bicycle is stationary.
- Unfasten and adjust the designated screw connections, and clamp them with the maximum tightening torque for the clamping screws of the handlebars.

**Maximum tightening torque for the clamping screws of the handlebars\***

5 Nm - 7 Nm

\*if there is no other data on the component

Table 28:

Handlebars clamping screw maximum tightening torque

## 6.3 Basic suspension setting

The adjustment shown here represents a basic setting. The rider should change the basic setting to suit the surface and his/her preferences.

- ▶ It is recommendable to make a note of the basic setting. This way, it can be used as the starting point for subsequent, optimised settings and to safeguard against unintentional changes.

### 6.3.1 Adjusting the hardness of the spring elements

#### 6.3.1.1 Adjusting the hardness of the steel suspension fork

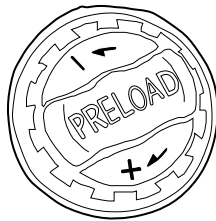

Figure 18:

#### Suspension fork setting wheel, example

- ✓ Only make the steel suspension fork setting with the bicycle stationary.
- ▶ The setting wheel may be located under a plastic cover on the head of the left-hand shock absorber. Remove the plastic cover by pulling it off upwards.
- ▶ Use the *setting wheel* on the left-hand *suspension fork head* to adjust the hardness of the steel suspension fork. Adjust the hardness of the steel suspension fork by turning the *setting wheel* in the plus or minus direction.
- ⇒ The ideal setting in relation to the weight of the rider has been achieved when the shock absorber deflects 3 mm under the stationary load of the rider.
- ▶ If applicable, re-attach the plastic cover after setting the suspension fork.

## Adjusting the bicycle to the rider

### 6.3.1.2 Adjusting the hardness of the air suspension elements

#### NOTICE

Riding without filling pressure will destroy the wheel suspension, the frame and the air suspension elements.

- ▶ Never ride without filling pressure in the air suspension elements.

#### NOTICE

A normal air pump cannot build up the required pressure with sufficient sensitivity.

- ▶ Use a special damper pump to adjust the filling pressure.

### 6.3.1.3 Front wheel



Figure 19:

- ✓ Only make the air suspension fork setting with the bicycle stationary.
- ▶ The fork valve is located underneath a screw cover on the head of the left-hand fork tube. Unscrew and remove the screw cover.

#### Fork valve, example

- ▶ Set the filling pressure using the filling pressure recommendations on the air suspension fork as the initial value.
  - ▶ Set the O-rings on the stanchion or the piston to the minimum possible deflection.
  - ▶ Sit on the bicycle and dismount again.
  - ▶ Read the position of the displaced O-ring.
- ⇒ The ideal setting for the weight of the rider has been achieved when the measured position is between 20 - 30%.

## Adjusting the bicycle to the rider

- ▶ For fine setting, adjust the filling pressure using the fork valve.
- ▶ Screw the screw cover back on.

### 6.4

#### Setting the grip distance of the brake lever

- ▶ Set the grip distance using the knurled screw on the brake lever.
- ⇒ The rider can use the brake lever comfortably.

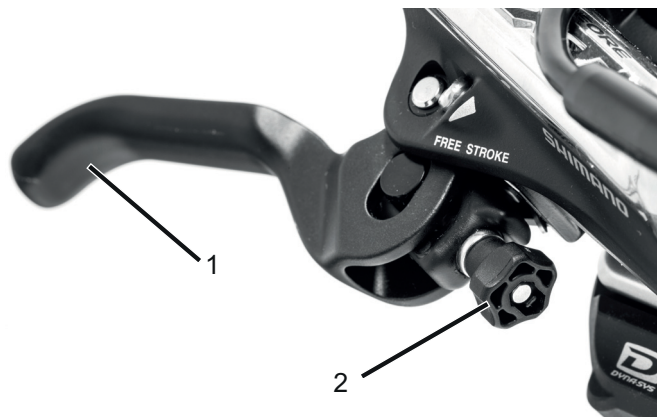

Figure 20:

Brake lever (1) with knurled screw (2)

## Operation

---

## 7 Operation

---



### Crash caused by loose clothing

Laces, scarves and other loose items may become entangled in the spokes on the *wheels* and the *chain drive*. This may result in a crash and injuries.

- ▶ Wear sturdy footwear and close-fitting clothing.



### Crash caused by soiling

Heavy soiling can impair the functions of the bicycle, for example, the function of the brakes. This may result in a crash and injuries.

- ▶ Remove coarse soiling before riding.



### Crash caused by poor road conditions

Loose objects, for example, branches and twigs, may become caught in the wheels and cause a crash.

- ▶ Be aware of the road conditions.
- ▶ Ride slowly and brake in good time.

### NOTICE

When riding downhill, high speeds may be reached. The bicycle is only engineered for exceeding a speed of 25 km/h briefly. In particular the *tyres* can fail if exposed to a continuous load.

- ▶ Decelerate the bicycle with the brakes if higher speeds than 25 km/h are reached.

### NOTICE

Heat or direct sunlight can cause the *tyre pressure* to increase above the permitted maximum pressure. This can destroy the *tyres*.

- ▶ Never park the bicycle in the sun.
  - ▶ On hot days, regularly check the *tyre pressure* and adjust it as necessary.
-

## Operation

The bicycle can be ridden within a temperature range of 5 °C - 35 °C. The effectiveness of the drive system is restricted outside of this temperature range.

---

<b>Operation temperature</b>	5 °C - 35 °C
------------------------------	--------------

---

As a result of the open construction, penetration from moisture at cold temperatures may impair individual bicycle functions.

- ▶ Always keep the bicycle dry and free from frost.
- ▶ If the bicycle is to be operated at temperatures below 3 °C, the HERCULES specialist dealer must first prepare the bicycle for winter service.



Off-road riding subjects the joints in the arms to severe strain. Take a break from riding every 30 to 90 minutes, depending on the condition of the roads.

## Operation

---

### 7.1 Before each ride

---



#### Crash caused by unidentified damage

After a crash, accident or if the bicycle falls over, there may be barely identifiable damage, e.g. to the brake system, the quick releases or the *frame*. This may result in a crash and injuries.

- ▶ Remove the bicycle from service and have a HERCULES specialist dealer carry out an inspection.



#### Crash caused by material fatigue

A component may suddenly fail in case of material fatigue. This may result in a crash and injuries.

Remove the bicycle from service immediately in case of any signs of material fatigue. Have the HERCULES specialist dealer check the situation.

- ▶ Have the HERCULES specialist dealer carry out basic cleaning regularly. During basic cleaning, the HERCULES specialist dealer inspects the bicycle for any signs of material fatigue.

- ▶ Check the bicycle before each ride.

⇒ In case of any discrepancies from the *Check list before each ride*, or any anomalies of any kind, the bicycle must not be used until the cause has been clarified.



**Check list before each ride**

<input type="checkbox"/>	Check that the bicycle is complete.
<input type="checkbox"/>	Check that the lighting, reflector and brake, for instance, are sufficiently clean.
<input type="checkbox"/>	You must check that the mudguards, the pannier rack and the chain guard are securely installed.
<input type="checkbox"/>	Check that the front and rear wheels run true. This is particularly important if the bicycle has been transported or secured with a lock.
<input type="checkbox"/>	Check the valves and the tyre pressure. Adjust as necessary before each ride.
<input type="checkbox"/>	Check the front and rear wheel brakes to make sure that they are working properly. To do so, operate the brake levers while the bicycle is stationary in order to check whether resistance is generated in the usual brake lever position.
<input type="checkbox"/>	Check that the running light is working.
<input type="checkbox"/>	Check for unusual noises, vibrations, smells, discolouration, deformation, abrasion and wear. This indicates material fatigue.
<input type="checkbox"/>	Be alert to any unusual operating sensations when braking, pedalling or steering.
<input type="checkbox"/>	Check the quick releases to make sure that they are fully closed in their final position.
<input type="checkbox"/>	On a bicycle with a hydraulic rim brake, check whether the locking levers are fully closed in their final positions.

## Operation

---

### 7.2 Using the kickstand

---



#### Crash caused by a lowered kickstand

The kickstand does not fold up automatically. There is a risk of crashing if riding with the kickstand lowered.

- ▶ Raise the kickstand completely before the ride.
- 

#### NOTICE

Because of the heavy weight of the bicycle, the kickstand may sink into soft ground, the bicycle may topple and fall over.

- ▶ The bicycle must only be parked on level, firm ground.
  - ▶ It is particularly important to check the stability if the bicycle is equipped with accessories or loaded with luggage.
- 

#### Raising the kickstand

- ▶ Before the ride, raise the kickstand completely with your foot.

#### Parking the bicycle

- ▶ Before parking, lower the kickstand completely with your foot.
- ▶ Park the bicycle carefully and check that it is stable.

## 7.3 Using the pannier rack (Alternative equipment)



### Crash caused by loaded pannier rack

The riding performance of the bicycle changes with a loaded *pannier rack*, in particular when steering and braking. This can lead to a loss of control. This may result in a crash and injuries.

- ▶ You should practice how to use a loaded *pannier rack* safely and reliably before using the bicycle in public spaces.



### Crash caused by unsecured luggage

Loose or unsecured objects on the *pannier rack*, e.g. belts, may become caught in the rear wheel. This may result in a crash and injuries.

Objects which are fastened to the pannier rack may cover the bicycle's *reflectors* and the *running light*. The bicycle may be overseen on public roads. This may result in a crash and injuries.

- ▶ Secure any objects which are attached to the *pannier rack* sufficiently.
- ▶ Objects fastened to the *pannier rack* must never cover the *reflectors*, the *lamp* or the *rear light*.



### Crushing the fingers in the spring flap

The spring flap on the *pannier rack* operates with a high clamping force. There is a risk of crushing the fingers.

- ▶ Never allow the spring flap to snap shut in an uncontrolled manner.
- ▶ Be careful where you position your fingers when closing the spring flap.

## Operation

---

### NOTICE

The maximum load bearing capacity is indicated on the *pannier rack*.

- ▶ Never exceed the permitted *total weight* when packing the bicycle.
  - ▶ Never exceed the maximum load bearing capacity of the *pannier rack*.
  - ▶ Never modify the *pannier rack*.
- 
- ▶ Distribute the luggage as evenly as possible on the left and right-hand side of the bicycle.
  - ▶ We recommend the use of panniers and luggage baskets.

## 7.4 Battery



### Risk of fire and explosion due to faulty battery

The safety electronics on damaged or faulty batteries may fail. The residual voltage can cause a short circuit. The batteries may self-ignite and explode.

- ▶ Remove batteries with external damage from service immediately and never charge them.
- ▶ If the battery becomes deformed or begins to smoke, keep at a safe distance, disconnect the power supply at the socket, and notify the fire service immediately.
- ▶ Never extinguish damaged batteries with water or allow them to come into contact with water.
- ▶ If a battery is dropped or struck but shows no signs of external damage, remove the battery from service and observe it for at least 24 hours.
- ▶ Faulty batteries are hazardous goods. Dispose of faulty batteries properly and as quickly as possible.
- ▶ Store in a dry place until disposal. Never store in the vicinity of flammable substances.
- ▶ Never open or repair the battery.



### Risk of fire and explosion due to high temperatures

Excessively high temperatures damage the battery. The battery may self-ignite and explode.

- ▶ Never expose the battery to sustained direct sunlight.

## Operation

---



### **Fire and explosion caused by short circuit**

Small metal objects may jumper the electrical connections of the battery. The batteries may self-ignite and explode.

- ▶ Keep paper clips, screws, coins, keys and other small parts away from the battery and do not insert them into the battery.



### **Chemical burns to the skin and eyes caused by faulty battery**

Liquids and vapours may leak from damaged or faulty batteries. They can irritate the airways and cause burns.

- ▶ Avoid contact with leaked liquids.
- ▶ Immediately consult a doctor in case of contact with the eyes or any discomfort.
- ▶ In case of contact with the skin, rinse off immediately with water.
- ▶ Ventilate the room well.



### **Fire and explosion caused by penetration by water**

The battery is only protected from simple spray water. Penetration by water can cause a short circuit. The battery may self-ignite and explode.

- ▶ Never immerse the battery in water.
  - ▶ If there is reason to believe that water may enter into the battery, the battery must be removed from service.
-

**NOTICE**

If a key is left inserted when transporting the bicycle, or when riding, it may break off or the compartment may open accidentally.

- ▶ Remove the key from the battery lock immediately after use.
- ▶ We recommend that you attach the key to a key ring.

## 7.4.1 Integrated battery

- ✓ Before the battery is to be removed or inserted, switch off the battery and the drive system.

### 7.4.1.1 Removing the integrated battery

- ▶ Open the battery lock with the key.
- ⇒ The integrated battery is released and falls into the retainer guard.
- ▶ Support the battery from below with your hand. Use the other hand to push on the retainer guard from above.
- ⇒ The integrated battery is completely released and falls into your hand.
- ▶ Pull the integrated battery from the frame.
- ▶ Remove the key from the lock.

## Operation

---

### 7.4.1.2

#### **Inserting the integrated battery**

- ▶ Place the battery in the bottom mount with the contacts first.
- ▶ Flip the integrated battery up so that it is held by the retainer guard.
- ▶ Push the integrated battery upwards so that it audibly clicks into place.
- ▶ Check the inserted battery to make sure it is firmly in place.
- ▶ Lock the battery with the key. Otherwise the battery may fall out of the mount when you open the lock.
- ▶ Remove the key from the lock.

### 7.4.2

#### **Down tube battery**

- ✓ Before the battery is to be removed or inserted, switch off the battery and the drive system.

### 7.4.2.1

#### **Removing the down tube battery**

- ▶ Open the battery lock with the key.
- ▶ Remove the key from the lock.
- ▶ Tip the down tube battery out of the top mount.
- ▶ Pull the down tube battery out of the top mount.



### 7.4.2.2

#### Inserting the down tube battery

- ▶ Place the down tube battery on the contacts in the bottom battery mount.
- ▶ Tip the battery into the top mount as far as it will go.
  - ⇒ There is an audible clicking noise.
- ▶ Check the inserted battery to make sure it is firmly in place.

### 7.4.3

#### Saddle tube battery

- ✓ Before the battery is to be removed or inserted, switch off the battery and the drive system.

#### 7.4.3.1

##### Removing the saddle tube battery

- ▶ Open the battery lock with the key.
- ▶ Remove the key from the lock.
- ▶ Swivel the saddle tube battery to the side out of the frame.
- ▶ Remove the saddle tube battery at the handle from the frame.

#### 7.4.3.2

##### Inserting the saddle tube battery

- ▶ Place the saddle tube battery at the handle into the frame.
- ▶ Swivel the saddle tube battery into the frame.
  - ⇒ The lock of the saddle tube battery engages.
- ▶ Lock the saddle tube battery with the key.
- ▶ Remove the key from the lock.

## Operation

---

### 7.4.4 Charging the battery

---



#### Fire caused by overheated charger

The charger heats up when charging the battery. In case of insufficient cooling, this can result in fire or burns to the hands.

- ▶ Never use the charger on a highly flammable surface (e.g. paper, carpet etc.).
  - ▶ Never cover the charger during the charging process.
- 



#### Electric shock caused by penetration by water

If water penetrates into the charger, there is a risk of electric shock.

- ▶ Never charge the battery outdoors.
- 



#### Electric shock in case of damage

Damaged chargers, cables and plug connectors increase the risk of electric shock.

- ▶ Check the charger, cable and plug connector before each use. Never use a damaged charger.
- 
- ▶ The ambient temperature during the charging process must be within the range from 10 °C to 30 °C.
- 

<b>Charging temperature</b>	10 °C - 30 °C
-----------------------------	---------------

---

- ✓ The battery can remain on the bicycle or be removed for charging.
- ✓ Interrupting the charging process does not damage the battery.
- ▶ Remove the rubber cover from the battery.

## Operation

- ▶ Connect the mains plug of the charger to a normal domestic, grounded socket.

**Connection data**

230 V, 50 Hz

- ▶ Connect the charging cable to the battery's charging port.
  - ⇒ The charging process starts automatically.
  - ⇒ During the charging process the operating and charge status indicator indicates the charge status. When the drive system is switched on, the *display* shows the charging process.
  - ⇒ The charging process is complete when the LEDs of the operating and charge status indicator go out.

**CAUTION** **Risk of fire and explosion caused by damaged batteries.** The safety electronics on damaged or faulty batteries may fail. The residual voltage can cause a short circuit. The batteries may self-ignite and explode. If the battery becomes deformed or begins to smoke, keep at a safe distance, disconnect the power supply at the socket, and notify the fire service immediately. Never extinguish damaged batteries with water or allow them to come into contact with water.

**NOTICE** If an error occurs during the charging process, a system message is displayed. Remove the charger and the battery from operation immediately and follow the instructions.

## Operation

---

### 7.4.5 Waking the battery

- ✓ When not used for a longer period, the battery switches to sleep mode for self-protection. The LEDs of the operating and charge status indicator do not light up.
- ▶ Press the *On-Off button (battery)*.
- ▶ The battery's operating and charge status indicator indicates the charge status.

## 7.5 Electric drive system

### 7.5.1 Switching on the drive system



#### Crash caused by lack of readiness for braking

When it is switched on, the drive system can be activated by the application of force on the pedals. There is a risk of a crash if the drive is activated unintentionally, and the brake is not reached.

- ▶ Never start the electric drive system, or switch it off immediately, if the brake cannot be reached safely and reliably.

- ✓ A sufficiently charged battery has been inserted on the bicycle.
- ✓ The battery is firmly in place. The key has been removed.
- ▶ Press and hold the **On-Off button (display)** for 2 seconds.
- ⇒ If the drive system is switched on, the drive is activated as soon as the pedals are moved with sufficient force.

### 7.5.2 Switching off the drive system

The system switches off automatically ten minutes after the last command. There are three options for switching off the drive system manually.

#### 1 Display On-Off key

- ▶ Press the **On-Off button (display)** once.
- ⇒ The LEDs of the operating and charge status indicator go out.

## Operation

---

### 7.6 Command console with display

#### 7.6.1 Using the USB port

The USB port can be used to operate external devices which can be connected using a standard micro A/ micro B USB 2.0 cable.

- ▶ Open the protective flap on the USB port.
- ▶ Replace the protective flap after using the USB port.

---

**NOTICE** Any moisture which enters through the USB port may trigger a short circuit in the *display*. Regularly check the position of the rubber cover on the USB port and adjust it as necessary.

---

#### 7.6.2 Removing and attaching the display

##### **NOTICE**

If the rider is not present, the *display* can be used without authorisation, e.g. it may be stolen, the system settings may be changed or journey information may be read.

- ▶ Remove the *display* when the bicycle is parked.

##### **Removing the display**

- ▶ Turn the *display* 45° anticlockwise.
- ▶ Remove the *display* from above.

**Attaching the display**

- ▶ Place the *display* on the *mount*.
- ▶ Turn the *display* 45° clockwise.

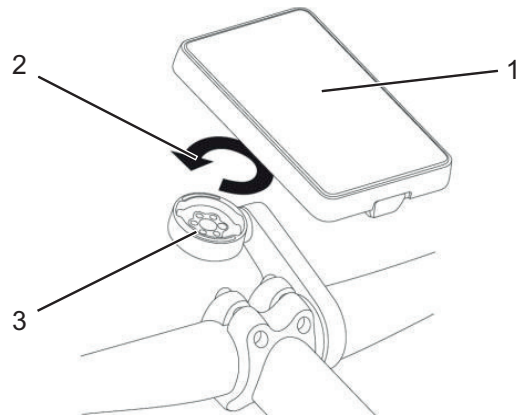
**Figure 21:****Attaching the display**

- 1 Display
- 2 Rotation direction of the display
- 3 Mount

## Operation

---

### 7.6.3 Using the pushing aid

---



#### Fall caused by strong acceleration

If the pedals are pressed with a pushing aid activated, the bicycle accelerates strongly. This may result in a crash and injuries.

- ▶ Never mount the bicycle with the pushing aid activated.

#### NOTICE

The pedals turn when using the pushing aid because of the design.

- ▶ When the pushing aid is in use, the bicycle must be steered securely with both hands.
- ▶ Allow for enough freedom of movement for the pedals.
- ▶ Never use a pushing aid for slow riding.

---

The pushing aid provides the rider with assistance when pushing the bicycle. The maximum speed can be 6 km/h here.

- ▶ Press and hold the **pushing aid button** for longer than three seconds.
- ⇒ The pushing aid is activated. The *pushing aid symbol* is displayed.
- ▶ Release the **pushing aid button** to shut off the pushing aid.



### 7.6.4 Using the running light

- ✓ To switch on the *running light*, the drive system has to be switched on already.
- ▶ Press the **lamp button** briefly.
- ⇒ The *running light* is switched on, and the *running light symbol* is displayed.
- ▶ Press the **lamp button** briefly again.
- ⇒ The *running light* is switched off, and the *running light symbol* is not displayed.

### 7.6.5 Selecting the level of assistance

- ▶ Press the **Plus button**.
- ⇒ The level of assistance is increased.
- ▶ Press the **minus button**.
- ⇒ The level of assistance is reduced.

### 7.6.6 Switching journey information

The displayed *journey information* can be changed and partially reset.

- ▶ Press the **info button** repeatedly until the *journey information* is displayed.

### 7.6.7 Changing the system information

- ▶ Press and hold the **lamp button** for three seconds.
- ▶ Press the **info button** repeatedly until the *journey information* is displayed.
- ▶ Change values by pressing the **minus** and **plus buttons**.
- ▶ When the values are correct, press the **info button** briefly.
- ▶ Press and hold the **lamp button** for three seconds.
- ⇒ The *journey information* is displayed again.

## Operation

---

### 7.7

### Gear shift

The selection of the appropriate gear is a prerequisite for a physically comfortable ride and making sure that the electric drive system functions properly. The ideal pedalling frequency is between 40 and 60 revolutions per minute.

- ▶ Select the appropriate gear with the *gear shift shifter*.
- ⇒ The gear shift switches the gear.

## 7.8 Brakes



### Crash caused by incorrect use

Handling the brake improperly can lead to loss of control or crashes, which may result in injuries.

- ▶ Practise braking and emergency braking before the bicycle is used in public spaces.
- ▶ Shift your weight back and down as far as possible.



### Crash caused by wet conditions

The *tyres* may slip on wet roads. In wet conditions you must also expect a longer braking distance. The braking sensation differs from the usual sensation. This can cause loss of control or a crash, which may result in injuries.

- ▶ Ride slowly and brake in good time.



### Crash after cleaning, servicing or repair

After cleaning, servicing or repairing the bicycle, the braking effect may be temporarily unusually weak. This may result in a crash and injuries.

- ▶ After cleaning, servicing or repair, carry out a few test brake applications.



### Burns caused by heated brake

The brakes may become very hot during operation. There is a risk of burns in case of contact.

- ▶ Never touch the components of the brake directly after the ride.

## Operation

---

The drive force of the motor is shut off during the ride as soon as the rider no longer pedals. The drive system does not switch off when braking.

- ▶ In order to achieve optimum braking results, do not pedal while braking.

### 7.8.1

#### Using the brake

- ▶ Pull the *brake levers* until the desired speed has been reached.

## 7.9 Locking the front wheel suspension

When the *fork lock* is in the open position, the *suspension system* has activated suspension and thus provides the rider and the bicycle with relief. Riding with the *fork lock* open should therefore be preferred for everyday riding.

When riding downhill or at high speed, for instance, the force which is exerted on the drive is absorbed by the *suspension system* and reduced by up to 50%. In these cases it is recommendable to close the suspension fork.

The *fork lock* may be situated directly on the fork or on the handlebars, depending on the version.



▶ In order to lock the *front wheel suspension*, shift the *locking lever* to the LOCK position.

▶ In order to release the *front wheel suspension*, shift the *locking lever* to the OPEN position.

Figure 22:

Fork lock on the suspension head with locking lever (1), example

## Maintenance

**8 Maintenance****Cleaning check list**

<input type="checkbox"/>	Lubricating the chain	once a month
<input type="checkbox"/>	Cleaning the battery	once a month
<input type="checkbox"/>	Basic cleaning and preservation of all components	at least every six months
<input type="checkbox"/>	Cleaning the charger	at least every six months

**Maintenance check list**

<input type="checkbox"/>	Checking the position of the USB rubber cover	before each ride
<input type="checkbox"/>	Checking for tyre wear	once a week
<input type="checkbox"/>	Checking for rim wear	once a week
<input type="checkbox"/>	Checking the tyre pressure	once a week
<input type="checkbox"/>	Checking for brake wear	once a month
<input type="checkbox"/>	Checking the electrical cables and Bowden cables for damage and to make sure they are fully functional	once a month
<input type="checkbox"/>	Checking the chain tension	once a month
<input type="checkbox"/>	Checking the tension of the spokes	every three months
<input type="checkbox"/>	Checking the gear shift setting	every three months
<input type="checkbox"/>	Checking the suspension fork for wear and to make sure it is fully functional	every three months

**Service check list**

<input type="checkbox"/>	Service by the specialist dealer	every six months
--------------------------	----------------------------------	------------------

## 8.1 Cleaning and servicing



### Crash and falling caused by unintentional activation

There is a risk of injury if the drive system is activated unintentionally.

- ▶ Remove the battery before cleaning.

The following servicing measures must be carried out regularly [ $\triangleright$  *Check list, page 80*]. Servicing can be performed by the user and rider. In case of any doubt, consult the HERCULES specialist dealer.

### 8.1.1 Battery



#### Fire and explosion caused by penetration by water

The battery is only protected from simple spray water. Penetration by water can cause a short circuit. The battery may self-ignite and explode.

- ▶ Never clean the battery with a high-pressure water device, water jet or compressed air.
- ▶ Never immerse the battery in water.
- ▶ Remove the battery from the bicycle before cleaning.
- ▶ Only clean the electrical connections of the battery with a dry cloth or brush.
- ▶ Wipe off the decorative sides with a damp cloth.

### 8.1.2 Display



If water enters into the *display*, it will be destroyed.

- ▶ Never immerse the *display* in water.
- ▶ Remove the *display* from the bicycle before cleaning.

## Maintenance

---

- ▶ Carefully clean the *display* with a damp, soft cloth.

### 8.1.3

#### Basic cleaning and preservation

---



##### Crash caused by brake failure

After cleaning, servicing or repairing the bicycle, the braking effect may be temporarily unusually weak. This may result in a crash and injuries.

- ▶ Never apply care products or oil to the brake disks or brake pads, or the braking surfaces on the rims.
  - ▶ After cleaning, servicing or repair, carry out a few test brake applications.
- 

#### NOTICE

Water may enter into the inside of the bearings if you use a steam jet. The lubricant inside is diluted, the friction increases and, as a result, the bearings are destroyed in the long term.

- ▶ Never clean the bicycle with a steam jet.
- 

#### NOTICE

Greased parts, e.g. the seat post, the handlebars or the stem, may no longer be safely and reliably clamped.

- ▶ Never apply grease or oil to the clamping areas.
  - ▶ Clean the bicycle with a damp cloth. Mix a little neutral soap with the cleaning water.
  - ▶ Then use wax or oil on the bicycle as a preservative agent.
- 

### 8.1.4

#### Chain

- ▶ Clean and lubricate the *chain* and the *chain wheels* using the stipulated care products.



## 8.2 Maintenance



### Crash and falling caused by unintentional activation

There is a risk of injury if the drive system is activated unintentionally.

- ▶ Remove the battery before maintenance.

The following maintenance measures must be carried out regularly [▷ *Check list, page 80*]. They can be carried out by the user and rider. In case of any doubt, consult the HERCULES specialist dealer.

### 8.2.1 Wheel

#### NOTICE

If the pressure is too low in the tyre, the tyre does not achieve its load bearing capacity. The tyre is not stable and may come off the rim.

If the pressure in the tyre is too high, the tyre may burst.

- ▶ Check the tyre pressure against the specifications [▷ *Data sheet, page 1*]
  - ▶ *Adjust the tyre pressure as necessary.*
- 
- ▶ Check the *tyre* wear.
  - ▶ Check the *rim* wear.
  - The rims with visible wear indicator are worn as soon as the black, all-round groove on the pad friction surface becomes invisible. We recommend that you also replace the *rims* with every second brake lining replacement.
  - ▶ Check the tension of the spokes.

## Maintenance

---

### 8.2.2 Brake system

- ▶ Replace the brake linings on the disk brake when the pad thickness has reached 0.5 mm.

### 8.2.3 Electrical cables and brake cables

- ▶ Check all visible electrical cables and cables for damage. If, for example, the sheathing is compressed, the bicycle will need to be removed from service until the cables have been replaced.
- ▶ Check all electrical cables and cables to make sure they are fully functional.

### 8.2.4 Gear shift

- ▶ Check the gear shift and the *shifter* or the *twist grip* setting and adjust it as necessary.

### 8.2.5 USB port

#### NOTICE

Any moisture which enters through the USB port may trigger a short circuit in the *display*.

- ▶ Regularly check the position of the *cover on the USB port* and adjust it as necessary.
-

## 8.2.6 Chain tension

### NOTICE

Excessive chain tension increases wear.

If the chain tension is too low, there is a risk that the *chain* will slip off the *chain wheels*.

- ▶ Check the chain tension once a month.
  - ▶ Check the chain tension in three or four positions, turning the crank a full revolution.
  - ▶ If the *chain* can be pushed more than 2 cm, the *chain* will need to be tensioned again by the HERCULES specialist dealer.
  - ▶ If the *chain* can only be pushed less than 1 cm, the *chain* will need to be relieved of tension accordingly.
- ⇒ The ideal chain tension has been achieved if the *chain* can be pushed a maximum of 2 cm in the middle between the pinion and the toothed wheel. The crank must also turn without resistance.

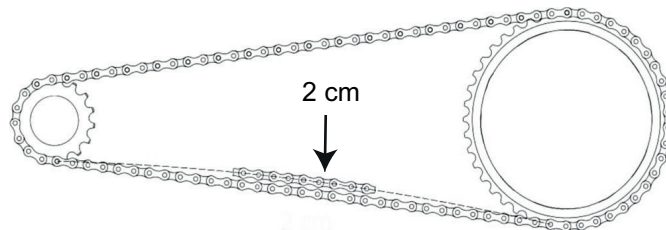

Figure 23: Checking the chain and belt tension

## Maintenance

### 8.3 Service



#### Crash and falling caused by unintentional activation

There is a risk of injury if the drive system is activated unintentionally.

- ▶ Remove the battery before the service.



#### Crash caused by material fatigue

If the service life of a component has expired, the component may suddenly fail. This may result in a crash and injuries.

- ▶ Have the HERCULES specialist dealer carry out six-monthly basic cleaning of the bicycle, preferably at the same time as the stipulated servicing work.

A service must be performed by the HERCULES specialist dealer at least every six months [*▶ Check list, page 80*]. This is the only way to ensure that the bicycle remains safe and fully functional.



- ▶ During basic cleaning, the HERCULES specialist dealer inspects the bicycle for any signs of material fatigue.
- ▶ The HERCULES specialist dealer checks the software version of the drive system and updates it. The electrical connections are checked, cleaned and preservative agent is applied. The electrical cables are inspected for damage.
- ▶ The further servicing measures correspond to those which are recommended for a bicycle as per EN 4210. Particular attention is paid to the rim and brake wear. The spokes are re-tightened in accordance with the findings.

## **8.4 Correcting and repairing**

### **8.4.1 Using original parts only**

The individual parts of the bicycle have been selected carefully and to matched to each other.

Only original parts must be used for maintenance and repair.

The constantly updated lists of approved accessories and parts are available to HERCULES specialist dealers.

## Maintenance

---

### 8.4.2 Wheel quick release

---



#### **CAUTION**

#### **Crash caused by unfastened quick release**

A faulty or incorrectly installed quick release may become caught in the brake disk and block the wheel. This will cause a crash.

- ▶ Install the front wheel quick release lever on the opposite side to the brake disk.



#### **CAUTION**

#### **Crash caused by faulty or incorrectly installed quick release**

The brake disk becomes very hot during operation. Parts of the quick release may become damaged as a result. The quick release comes loose. This will result in a crash and injuries.

- ▶ The front wheel quick release lever and the brake disk must be situated on opposite sides.



#### **CAUTION**

#### **Crash caused by incorrectly set clamping force**

Excessively high clamping force will damage the quick release and cause it to lose its function.

Insufficient clamping force will cause a detrimental transmission of force. The suspension fork or the frame may break. This will result in a crash and injuries.

- ▶ Never fasten a quick release using a tool (e.g. hammer or pliers).
  - ▶ Only use the clamping lever with the specified set clamping force.
-

The clamping lever for the quick release is marked OPEN and CLOSE. If you can read the word OPEN, the quick release is open. If you can read the word CLOSE, the quick release is clamped.

⇒ The wheel clamping lever is clamped if the clamping lever can be moved easily from the open final position into the middle and has to be pressed with the fingers or base of the thumb from the middle point onwards.

#### 8.4.2.1

#### Clamping the quick release

- ▶ Hold the open clamping lever. Fasten the setting nut on the opposite side.
  - ▶ Clamp the clamping lever.
- ⇒ The final position of the clamping lever is at a right angle to the fork or frame.

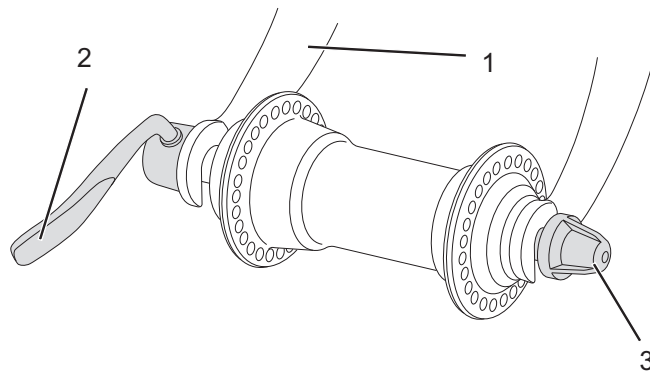

Figure 24:

Wheel quick release, version I, with clamping lever (2), fork (1) and setting nut (3)

## Maintenance

---

### Checking and setting the clamping force of the quick releases

If the clamping lever cannot be moved into its proper final position by pushing it with the hand, or if it is too loose, its clamping force will need to be readjusted.

- ▶ Open the clamping lever completely.
- ▶ Unfasten the setting nut a little.
- ▶ Clamp the clamping lever.
- ▶ If the clamping lever is not yet in the proper final position, repeat the steps until the proper final position has been achieved.



## 8.4.3 Adjusting the tyre pressure

### 8.4.3.1 Dunlop valve

The tyre pressure cannot be measured on the simple Dunlop valve. The tyre pressure is therefore measured in the filling hose when pumping slowly with the bicycle pump.

- ✓ It is recommendable to use a bicycle pump with a pressure gauge. The operating instructions for the bicycle pump must be adhered to.
- ▶ Unscrew and remove the valve cap.
- ▶ Connect the bicycle pump.
- ▶ Pump up the tyre slowly and pay attention to the tyre pressure in the process.
- ⇒ The tyre pressure has been adjusted as per the data [*> Data sheet, page 1*].
- ▶ If the tyre pressure is too high, unfasten the union nut, let off air and tighten the union nut again.
- ▶ Remove the bicycle pump.
- ▶ Screw the valve cap tight.
- ✓ Screw the rim nut gently against the rim with the tips of your fingers.

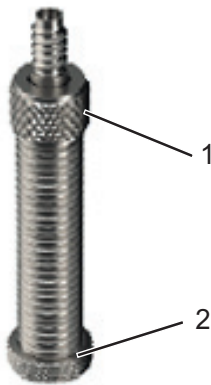

Figure 25: Dunlop valve with union nut (1) and rim nut (2)

## Maintenance

### 8.4.3.2

### Presta valve

- ✓ It is recommendable to use a bicycle pump with a pressure gauge. The operating instructions for the bicycle pump must be adhered to.
- ▶ Unscrew and remove the valve cap.
- ▶ Open the knurled nut around four turns.
- ▶ Carefully apply the bicycle pump so that the valve insert is not bent.
- ▶ Pump up the tyre slowly and pay attention to the tyre pressure in the process.
- ⇒ The tyre pressure has been adjusted as per the data [▷ *Data sheet, page 1*].
- ▶ Remove the bicycle pump.
- ▶ Tighten the knurled nut with your finger tips.
- ▶ Screw the valve cap tight.
- ▶ Screw the rim nut gently against the rim with the tips of your fingers.

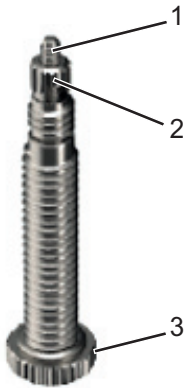

Figure 26:

Presta valve with valve insert (1), knurled nut (2) and rim nut (3)

**8.4.3.3****Schrader valve**

- ✓ It is recommendable to use a bicycle pump with a pressure gauge. The operating instructions for the bicycle pump must be adhered to.
- ▶ Unscrew and remove the valve cap.
- ▶ Connect the bicycle pump.
- ▶ Pump up the tyre slowly and pay attention to the tyre pressure in the process.
- ⇒ The tyre pressure has been adjusted as per the data [[▷ Data sheet, page 1](#)].
- ▶ Remove the bicycle pump.
- ▶ Screw the valve cap tight.
- ▶ Screw the rim nut gently against the rim with the tips of your fingers.

**Figure 27:****Schrader valve with rim nut (1)**

## Maintenance

### 8.4.4 Setting the gear shift

If the gears cannot be selected cleanly, the tension of the shift cable will need to be readjusted.

- ▶ Carefully pull the *adjusting sleeve* away from the shifter housing, turning it in the process.
- ▶ Check the function of the gear shift after each adjustment.



If the gear shift cannot be set this way, the assembly of the gear shift will need to be inspected by the HERCULES specialist dealer.

#### 8.4.4.1

#### Cable-operated gear shift, single-cable

- ▶ For a smooth gear shift, set the adjusting sleeves on the gear shift housing.



Figure 28: Adjusting sleeve (1) for the single-cable cable-operated gear shift with shifter housing (2), example

#### 8.4.5 Offsetting brake lining wear

The brake pad wear on the disk brake does not require readjustment.

#### 8.4.6 Replacing the lighting

Alternatively a 3 watt or 1.5 watt lighting system can be installed.

- ▶ Only use components of the respective power class for replacement.

#### 8.4.7 Setting the lamp

- ▶ The *lamp* must be set so that its light beam meets the road 10 m in front of the bicycle.

#### 8.4.8 Repair by the specialist dealer



Special knowledge and tools are required for many repairs. Only a HERCULES specialist dealer must carry out the following repairs, for instance:

- Replacing *tyres* and rims,
- Replacing the brake pads and brake linings,
- Replacing and tensioning the *chain*.

## Maintenance

### 8.4.9

#### The electric drive system of drive system does not start up

If the display and/or the drive system do not start up, proceed as follows:

- ▶ Check whether the battery is switched on. If not, start the battery.
- ⇒ If the LEDs of the charge status indicator do not light up, contact the HERCULES specialist dealer.
- ▶ If the LEDs of the charge status indicator light up, but the drive system does not start up, remove the battery.
- ▶ Insert the battery.
- ▶ Start the drive system.
- ▶ If the drive system does not start up, remove the battery.
- ▶ Clean all the contacts with a soft cloth.
- ▶ Insert the battery.
- ▶ Start the drive system.
- ▶ If the drive system does not start up, remove the battery.
- ▶ Fully charge the battery.
- ▶ Insert the battery.
- ▶ Start the drive system.
- ▶ If the drive system does not start up, remove the display.
- ▶ Fasten the display.
- ▶ Start the drive system.
- ▶ If the drive system does not start up, contact the HERCULES specialist dealer.

## 8.4.10

### First aid for system messages



#### Fire and explosion due to faulty batteries

The safety electronics on damaged or faulty batteries may fail. The residual voltage can cause a short circuit. The batteries may self-ignite and explode.

- ▶ Batteries with external damage must be removed from service immediately.
- ▶ Never allow damaged batteries to come into contact with water.
- ▶ If a battery is dropped or struck but shows no signs of external damage, remove the battery from service and observe it for at least 24 hours.
- ▶ Faulty batteries are hazardous goods. Dispose of faulty batteries properly and as quickly as possible.
- ▶ Store in a dry place until disposal. Never store in the vicinity of flammable substances.
- ▶ Never open or repair the battery.

The components of the drive system are checked constantly and automatically. If an error is detected, the respective error code appears on the *display*. The drive may be shut off automatically, depending on the type of error.

### 8.4.10.1

#### First aid

If an error message is displayed, run through the following actions:

- ▶ Make a note of the system message.
- ▶ Shut off and re-start the drive system.
- ▶ If the system message is still displayed, remove and then re-insert the battery.
- ▶ Re-start the drive system.
- ▶ If the system message is still displayed, contact the HERCULES specialist dealer.

## Maintenance

### 8.4.10.2

#### Specific error eradication

- ▶ Make a note of the system message.

Error	Remedy
10	▶ Charge the battery.
12	▶ Charge the battery.
24	Incorrect charger. ▶ Use the supplied charger for charging.
40, 41, 44	Overcurrent detected and motor overheating ▶ Relieve the motor with reduced pedalling or a lower assistance level.

Table 29:

#### Error eradication using the code

- ▶ If the system message is still displayed, contact the HERCULES specialist dealer.



## 8.5 Accessories

For bicycles without a kickstand we recommend a parking stand into which either the front or rear wheel can be inserted securely. The following accessories are recommended:

<i>Description</i>	<i>Article number</i>
Protective cover for electrical components	080-41000 ff
Panniers system components*	080-40946
Rear wheel basket system components*	051-20603
Bicycle box system components*	080-40947

**Table 30:**

### **Accessories**

\*System components are matched to the pannier rack and provide sufficient stability due to special transmission of force.

## Maintenance

---

### 8.5.1 Child seat

---



#### Crash caused by improper handling

When using child seats, the riding properties and the stability of the bicycle change considerably. This can cause a loss of control, a crash and injuries.

- ▶ You should practice how to use the child seat safely and reliably before using the bicycle in public spaces.



#### Risk of crushing due to exposed springs

The child may crush his/her fingers on exposed springs or open mechanical parts of the saddle or the seat post.

- ▶ Never install saddles with exposed springs if a child seat is being used.
- ▶ Never install seat posts with suspension with open mechanical parts or exposed springs if a child seat is being used



#### NOTICE

- ▶ Observe the legal regulations on the use of child seats.
  - ▶ Observe the operating and safety notes for the child seat system.
  - ▶ Never exceed the total weight of the bicycle.
-



The HERCULES specialist dealer will advise you on the choice of right child seat system for the child and the bicycle. The scope of delivery of commercially available child seats does not usually contain any of the material which is required to adapt the bicycle to the child seat.

Moreover, knowledge, skills and tools which a technical layperson does not have, may be required.

Therefore, the initial installation of a child seat must be performed by the HERCULES specialist dealer in order to maintain operational and product safety. When installing a child seat, the HERCULES specialist dealer makes sure that the seat and the fastening mechanism for the seat suit the bicycle, that all components are installed and firmly fastened, that shift cables, brake cables, hydraulic and electrical cables are adjusted as necessary, that the freedom of movement of the rider is not restricted, and the permitted total weight of the bicycle is not exceeded.

The HERCULES specialist dealer provides instruction on how to handle the bicycle and the child seat.

## Maintenance

### 8.5.2 Bicycle trailer



#### CAUTION

#### Crash caused by brake failure

The brake may not work sufficiently if there is an excessive trailer load. The long braking distance can cause a crash or an accident and injuries.

▶ Never exceed the specified trailer load.



#### NOTICE

▶ The operating and safety notes for the trailer system must be observed.

▶ The legal regulations on use of bicycle trailers must be observed.

▶ Only use type approved coupling systems.

A bicycle which is approved for towing a trailer is equipped with the respective information sign. Only bicycle trailers with a support load and total mass which do not exceed the permitted values, must be used.



The HERCULES specialist dealer will advise you on the choice of right trailer system for the bicycle. The scope of delivery of commercially available bicycle trailers does not usually contain any of the material which is required to adapt the bicycle to the trailer. Moreover, knowledge, skills and tools which a technical layperson does not have, may be required.

Therefore, the initial installation of a trailer must be performed by the HERCULES specialist dealer in order to maintain operational and product safety.

## 9 Recycling and disposal



### Risk of fire and explosion

The safety electronics on damaged or faulty batteries may fail. The residual voltage can cause a short circuit. The batteries may self-ignite and explode.

- ▶ Remove batteries with external damage from service immediately and never charge them.
- ▶ If the battery becomes deformed or begins to smoke, keep at a safe distance, disconnect the power supply at the socket, and notify the fire service immediately.
- ▶ Never extinguish damaged batteries with water or allow them to come into contact with water.
- ▶ Faulty batteries are hazardous goods. Dispose of faulty batteries properly and as quickly as possible.
- ▶ Store in a dry place until disposal. Never store in the vicinity of flammable substances.
- ▶ Never open or repair the battery.



### Chemical burns to the skin and eyes

Liquids and vapours may leak from damaged or faulty batteries. They can irritate the airways and cause burns.

- ▶ Avoid contact with leaked liquids.
- ▶ Immediately consult a doctor in case of contact with the eyes or any discomfort.
- ▶ In case of contact with the skin, rinse off immediately with water.
- ▶ Ventilate the room well.

## Recycling and disposal

---

The bicycle, the battery, the display and the charger are recyclable materials. They have to be disposed of separate from the domestic waste in accordance with the valid legal regulations, and recycled.

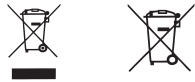

Separate collection and recycling saves reserves of raw materials and ensures that all the regulations for protection of health and the environment are adhered to when recycling the product and/or the battery.

- ▶ Never dismantle the bicycle, the battery or the charger for disposal.
- ▶ The bicycle, the display, the unopened and undamaged battery and the charger can be returned to any HERCULES specialist dealer free of charge. Depending on the region, further disposal options may be available.
- ▶ Store the individual parts of the decommissioned bicycle in a dry place, free from frost, where they are protected from direct sunlight.

## 10 EC declaration of conformity

### Translation of the original EC declaration of conformity

The manufacturer:

HERCULES GMBH  
Longericher Straße 2  
50739 Köln

hereby declares that the electrically power assisted cycles of types:

18-R-0001, 18-R-0002, 18-R-0003, 18-R-0005

year of manufacture 2017 and year of manufacture 2018,

comply with all applicable requirements of **Machinery Directive 2006/42/EC**. Furthermore, the electrically power assisted cycles comply with all applicable basic requirements of **Electromagnetic Compatibility Directive 2014/30/EU**.

The following standards were applied: **EN ISO 12100:2010** Safety of machinery – General principles of design – Risk assessment and reduction, **EN ISO 4210-2:2015**, Cycles – Safety requirements for bicycles – Part 2: Requirements for city and trekking, young adult, mountain and racing bicycles, **EN 15194:2009+A1:2011**, Cycles – Electrically power assisted cycles – EPAC bicycles, **EN 11243:2016**, Cycles – Luggage carriers for bicycles – Requirements and test methods.

Mr. Harald Guoth Dipl.-Ing. (FH) (Quality Management Officer, Compliance Officer), c/o HERCULES GMBH, Longericher Str. 2, 50739 Köln

is authorised to compile the technical documentation.



Cologne, 06.09.2017

.....  
Place, date and signature

Georg Honkomp

-Managing Director-

## Table of figures

**12 Table of figures**

Figure 1:	Type plate, example, 19
Figure 2:	Bicycle, viewed from the right, example of Pasero, 24
Figure 3:	Detailed view of bicycle from rider position, example, 25
Figure 4:	Components of the wheel, example of front wheel, 26
Figure 5:	Bicycle without suspension (1) and with suspension (2) when riding over an obstacle, 27
Figure 6:	Bicycle brake system with a disk brake, example, 28
Figure 7:	Diagram of drive system, 29
Figure 8:	Diagram of electric drive system, 30
Figure 9:	Integrated battery details, 32
Figure 10:	Details of the down tube battery from the right (I) and left (II), 33
Figure 11:	Seat tube battery details, 33
Figure 12:	Display details, 35
Figure 13:	Overview of the displays, 36
Figure 14:	Overview of the command console, 40
Figure 15:	Detailed view of the seat post, examples of the minimum insertion depth marking, 50
Figure 16:	Determining the saddle height, 51
Figure 17:	Seat post quick release in the final position, 51
Figure 18:	Suspension fork setting wheel, example, 53
Figure 19:	Fork valve, example, 54
Figure 20:	Brake lever (1) with knurled screw (2), 55
Figure 21:	Attaching the display, 73
Figure 22:	Fork lock on the suspension head with locking lever (1), example, 79
Figure 23:	Checking the chain and belt tension, 85
Figure 24:	Wheel quick release, version I, with clamping lever (2), fork (1) and setting nut (3), 89
Figure 25:	Dunlop valve with union nut (1) and rim nut (2), 91
Figure 26:	Presta valve with valve insert (1), knurled nut (2) and rim nut (3), 92
Figure 27:	Schrader valve with rim nut (1), 93
Figure 28:	Adjusting sleeve (1) for the single-cable cable-operated gear shift with shifter housing (2), example, 94



## 13 Index

### A

Alternative equipment, 17  
Alternative version, 17

### B

Basic cleaning, 82  
Battery, 32, 33  
- charging, 68  
- checking, 48  
- cleaning, 81  
- disposing of, 104  
- eradicating charging faults, 97  
- waking, 70  
Belt tension, 85  
Bike stand, see Kickstand  
Brake caliper, 28  
Brake disk, 28  
Brake lever, 25  
Brake linings, 28  
Brake pad,  
- maintaining, 84  
Break in operation, 43  
- carrying out, 44  
- preparing, 44  
Button,

Info (command console), 40  
Minus, 40  
Plus, 40  
Running light, 35

### C

Chain drive, 29  
Chain guard, 24  
- checking, 59  
Chain tension, 85  
Chain wheel, 29  
Chain, 24, 29  
- cleaning, 82  
- maintaining, 85  
- replacing, 95  
Charge status indicator, 34  
Charger,  
- disposing of, 104  
Clamping lever,  
Seat post, 51  
Clock, 38

### D

Data sheet, 1  
Direction of travel, 29  
Display, 34  
- attaching, 73  
- cleaning, 82  
- removing, 72  
Drive system, 29  
- switching off, 71  
- switching on, 71

### E

EC declaration of conformity, 105

### F

Fault message, see System message, 97  
Fork lock, 25  
Fork, 26  
Fork end, 26  
Frame number, 1  
Frame, 24  
Front wheel brake, 28  
- braking, 78  
Front wheel, see Wheel

### G

Gear shift twist grip,  
- checking, 84  
Gear shift,  
- maintaining, 84  
- switching, 76

### H

Handlebars, 24, 25  
- installing, 47  
- setting, 52  
Hub, 26

### I

Info button, 40  
Initial commissioning, 46

### J

Journey information, 38  
- resetting, 75  
- switching, 75  
Clock, 38  
Max Speed, 38

### K

Knurled nut, 51

### L

Lamp, 24, 30  
Level of assistance, 37, 40  
- selecting, 75  
Lighting, see Running light

### M

Mass, see Weight  
Minimum insertion depth marking, 50  
Minus button, 40  
Model year, 19  
Model, 1  
Motor, 30  
Mudguards, 24  
- checking, 59

### O

Operating status indicator, 34

### P

Packaging, 45  
Pannier rack, 24  
- checking, 59  
- modifying, 62  
- using, 61  
Parts list, 105  
Pedal, 29  
Plus button, 40  
Pushing aid,  
- using, 74

### Q

Quick release, 26

### R

Rear light, 24, 30  
Rear wheel brake 28  
Rear wheel, see Wheel  
Reflector, 24  
Rim, 26  
- checking, 83  
- replacing, 95  
Running light button, 35  
Running light, 34  
- checking function, 59  
- replacing, 95

## Index

---

### S

- Saddle, 24
  - changing the saddle tilt, 52
  - changing the seat length, 52
  - clamping, 51
  - determining the saddle height, 50
  - installing, 47
- Screen display, 36
- Seat post, 24
- Shifter, 25
  - checking, 84
  - setting, 86, 93, 95
- Spoke, 26
- Storage, 43
- Storing, see Storage
- Suspension fork, 27
- Suspension head, 26
- Suspension, 27
- System message, 39
  - understanding, 97
- System setting, 38
  - changeable, 38

### T

- Transportation, 41
- Transporting, see Transportation
- Type number, 1, 19
- Tyre pressure, 1
- Tyre size, 1
- Tyre, 26
  - replacing, 95
- Tyres,
  - checking, 83

### U

- USB port,
  - using, 72

### V

- Valve, 26
  - Dunlop valve 26
  - Presta valve, 26
  - Schrader valve, 26

### W

- Weight,
  - Maximum weight, 19
  - Unladen weight, 1
- Wheel circumference, 1
- Wheel,
  - maintaining, 83
- Winter break, see Break in operation
- Working environment, 45

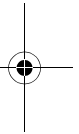
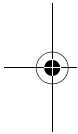

Text and images:  
HERCULES GMBH  
Longericher Straße 2  
50739 Köln, Germany

Translation:  
Tanner Translations GmbH+Co  
Markenstraße 7  
40227 Düsseldorf, Germany

Operating instructions: 034-11421\_1.0\_11.10.2017

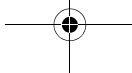

[www.hercules-bikes.de](http://www.hercules-bikes.de)

HERCULES GMBH  
Longericher Straße 2  
50739 Köln, Germany

Tel.: +49 4471 18735-0  
Fax: +49 4471 18735-29  
E-mail: [info@hercules-bikes.de](mailto:info@hercules-bikes.de)

**YOUR HERCULES SPECIALIST DEALER**

